

# alitherm 300

STANDARD STAY MANUAL



---

Smart Architectural Aluminium

**Alitherm 300 Standard Stay**  
**Technical Fabrication Manual**  
JULY 2011

© Smart Systems Ltd 2011

---

**ETC**



**Main Index**

**ETC** Index

Index ..... Page 01

**A** **ETC**

**Profiles**

Specification Pages ..... Page A02-A06  
 Technical Information ..... Page A07-A12  
 Scale Profile Drawings ..... Page A13-A30

**B** **ETC**

**Accessories**

Photos & Drawings ..... Page B02-B24

**C** **ETC**

**Sections**

Scale Sections - ..... Page C02-C24

**D** **ETC**

**Statics**

Open Out ..... Page D02

**E** **ETC**

**Construction Drawings  
 Standard Stays**

1 - Corner Jointing ..... Page E02-E04  
 2 - Drainage ..... Page E05-E06  
 3 - Transom/Mullion ..... Page E07-E09  
 4 - Hinges..... Page E10  
 5 - Locking Hardware.... Page E11-E13  
 6 - Bead & Glazing ..... Page E14-E16  
 7 - Coupling/Bay Poles . Page E17-E18

**F** **ETC**

**Sawing Tables**

Cutting Information - Standard Stays ..... Page F02-F03

## Specification

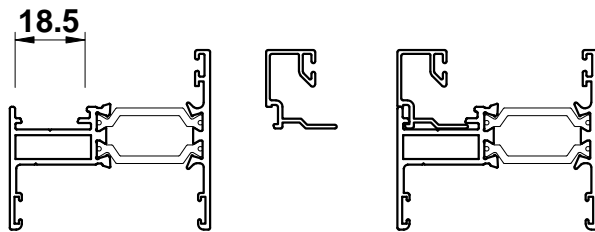
### GENERAL DESCRIPTION

The "Alitherm 300" window system described in this manual is suitable for both replacement windows for existing buildings, and for installation into new buildings.

The system incorporates internally & externally beaded vent frames suitable for cockspur and shootbolt locking.

The low line gaskets and extended polyamide thermal breaks help to provide excellent U Values and Window Energy Rating capable of achieving an 'A' Rating when used in conjunction with the correct double glazed unit.

#### Standard Stays



Corner assembly of Alitherm 300 is crimping only.

### RECOMMENDED DESIGN LIMITATIONS

#### **Top Hung Vents:**

Maximum Width: 1400mm  
Minimum Width: 350mm  
Maximum Height: 1300mm  
Minimum Height: 220mm  
Maximum Weight: 40kg

#### **Side Hung Vents:**

Maximum Width: 700mm  
Minimum Width: 400mm  
Maximum Height: 1400mm  
Minimum Height: 350mm  
Maximum Weight: 28kg

## Specification

### PROFILE SPECIFICATION

The window frame are constructed of aluminium alloy extrusion to BS EN 755-9 and BS EN 12020, extruded from 6063 T6 alloy. The internal and external extrusions are separated with a polyamide thermal break.

The external aluminium alloy extrusion is pre-treated and finished either:-

- a) Anodised to BS 3987: 1987, grade AA25 to a natural self colour.
- b) Polyester powder organic coating to BS 6496. Dual colour is available.

### GENERAL MANUFACTURING

Outer and vent frames are made by cutting the frame profiles with accurate 45° mitred ends using Tungsten Carbide Tipped Saw Blades, operating at approximately 3000 rpm.

The corners are joined using the Alitherm 300 crimping tools to form a cold forged corner joint (made by deforming small slugs of metal into the groove of the corner cleat).

The ends of transoms and mullions are profiled to fit the frame and fixed using self-tapping screws with a silicone seal.

On polyester powder coated finishes, great care should be taken to avoid getting gap sealer on visible surfaces and should be removed as soon as possible with a clean cloth.

Care should be exercised when using products not supplied by Smart Systems Ltd as no responsibility can be accepted.

## Specification

### WINDOW DRAINAGE

As with all dry glazed systems, it is recommended that the window system is adequately drained and ventilated. Refer to drainage details in manual, if in doubt ask The Technical Department.

In order to get maximum performance and weather resistance it is recommended that drips are used over all vents.

### OUTER FRAME MANUFACTURING INFORMATION

The outer frame members are cut with 45° mitred ends to the overall size required, measured to the longest point of the metal.

Prior to corner crimping the centre line position of any transoms or mullions should be marked on the outer frame members. Where the transom/mullion runs right through, it should be marked out on both jambs or head and cill members in pairs to ensure accurate alignment of the sections.

Using the marked centre line, Drill the transom/mullion fixing holes using a 5mm dia. drill bit.

Corners are formed by coating the cut faces to be joined with a suitable small gap sealer. Into the mitred corner insert the cleat glue and the required corner cleats and, where required, the aluminium corner chevrons. The two mitred ends are then brought together and crimped. The small gap sealer ensures a permanent joint and guards against the ingress of moisture and joint movement. After crimping the corner joint, special care should be taken to ensure any excess sealer is removed from painted surfaces.

Transoms or mullions are cut with square ends to the sizes calculated on the cutting formula sheets. The ends are then profiled to allow them to fit into the outer frame. Special tooling is available on request to profile the end of transom/mullion.

Prior to fixing of transoms and mullions smear the cut ends with a suitable gap sealer. After fixing, special care should be taken to ensure any excess is cleared from painted surfaces.

## Specification

### VENT

Corners are formed by coating the cut faces to be joined with a suitable gap sealer. In the mitred corner insert the cleat glue and the required corner cleats and chevrons. The mitred ends are then brought together and crimped. The small gap sealer ensures a permanent joint and guards against the ingress of moisture and joint movement. Care should be taken to ensure any excess sealer is removed from the surfaces.

The cutting sizes produce vent frames with a cavity of 13mm.

When fixing, the friction stays into both the outer and vent frame, care should be taken to ensure that holes are located on 'V' grooves in the aluminium extrusions.

### INTERNALLY BEADED ADAPTOR FRAME

The internally beaded adaptor frame members are cut with 45° mitred ends to the overall size required, measured to the longest point of metal. Care should be taken when measuring and cutting the frame members as only nominal clearance is required when the assembled frame is fixed in the outer frame.

Corners are formed by coating the cut faces to be joined with a suitable small gap sealer. Into the mitred corner insert the cleat glue and a corner cleat and the required corner chevrons. The small gap sealer ensures a permanent joint and guards against the ingress of moisture and joint movements. Care should be taken to ensure any excess sealer is removed from painted surfaces.

## Specification

### MULTI-POINT LOCKING

The vent should be prepped for the locking mechanism prior to fabrication and fitted into vent before hanging. Stainless steel fixing should be used for securing the locking mechanism and keeps in position.

### TOP HUNG VENTILATORS WHEN USING COCKSPUR HANDLES

If the width of the ventilator frame is less than 750mm, fit one handle.

If the width of the ventilator is greater than 750mm, fit two handles.

### SIDE HUNG VENTILATORS WHEN USING COCKSPUR HANDLES

If the height of the ventilator frame is less than 750mm, fit one handle.

If the height of the ventilator is greater than 750mm, fit two handles.

### GLAZING

All beads are cut to suit the glazing aperture on the fully assembled window for glazing either at factory or on site as required.

### INTERNALLY BEADED GLAZING

Glazing beads are fitted to openings by cutting the horizontal beads square to head and cill of each vent and fixed light area. Vertical beads are cut square at both ends. Insert bottom beads and two setting blocks to ensure glass will be centralised in vertical dimension of opening (glazing blocks must be full width of cavity to fully support glass or sealed unit), then insert top bead followed by side beads. Finish glazing by insertion of internal gaskets all round.

For maximum weather performance, apply silicone to the full width of the bottom bead and 100mm up from the bottom of the vertical beads.

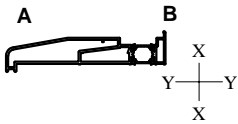
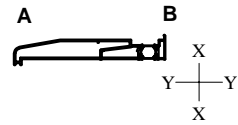
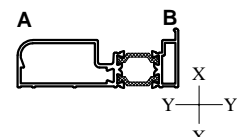
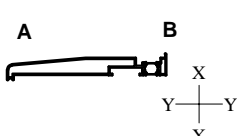
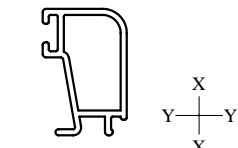
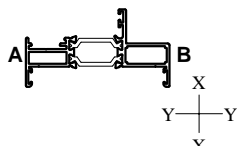
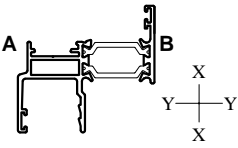
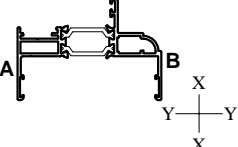
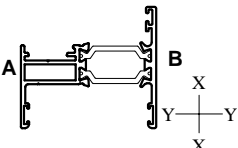
### Alitherm 300 Window Weather Performance (BS6375)

BS EN 1026: 2000 Air Permeability:	Class 4 600Pa
BS EN 1027: 2000 Watertightness:	Class E 1200Pa
BS EN 12211: 2000 Resistance to Wind Load:	Class E 2400Pa

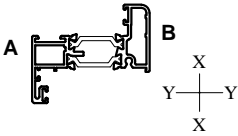
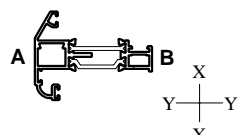
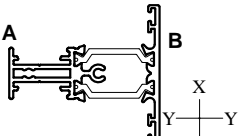
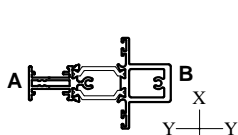
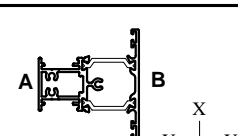
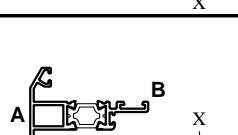
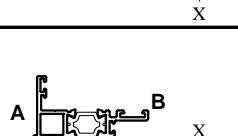
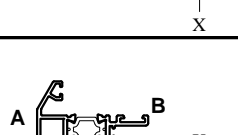
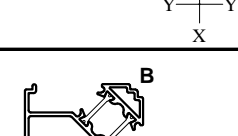
### Alitherm 300 Window U Values

Contact The Technical Department

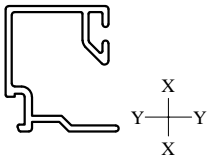
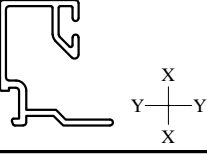
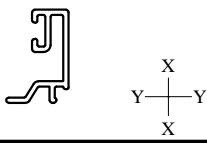
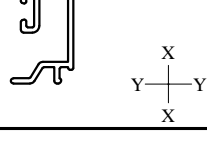
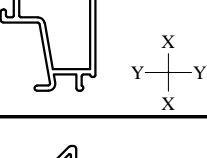
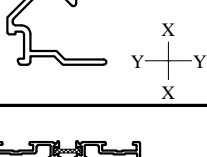
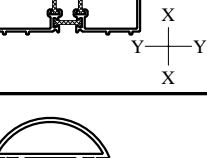
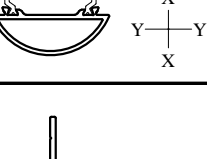
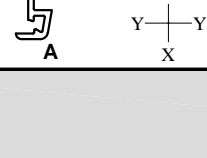


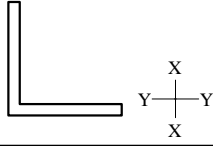
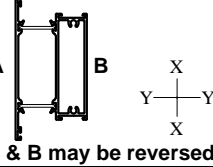
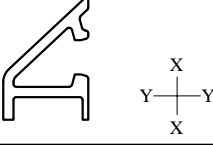
Number	Picture	Page	Perim. mm	Mec. mm	lx(cm4) wx(cm3)	ly(cm4) wy(cm3)	Length	Pack pr.	MF	SA	KL	HP	M
<b>ETC157</b>		A23	391	131	170.46 — 21.92	7.66 — 3.86	6.5	1	X	X	X	X	X
<b>ETC158</b>		A23	513	205	330.30 — 33.08	91.30 — 4.923	6.5	1	X	X	X	X	X
<b>ETC178</b>		A24	502	133	33.53 — 7.363	3.485 — 2.893	6.5	1	X	X	X	X	X
<b>ETC179</b>		A24	626	284	519.58 — 44.68	9.15 — 4.89	6.5	1	X	X	X	X	X
<b>ETC273</b>		A21 & A22	88	31	- ----- -	- ----- -	6.5	1	X	X	X	X	
<b>ETC307</b>		A13	342	103	23.1 ----- 2.29	5.97 ----- 1.30	6.5	1	X	X	X	X	X
<b>ETC308</b>		A13	357	83	12.96 ----- 4.27	4.48 ----- 1.74	6.5	1	X	X	X	X	X
<b>ETC309</b>		A13	389	119	27.62 ----- 7.26	4.45 ----- 1.63	6.5	1	X	X	X	X	
<b>ETC310</b>		A14	322	86	14.20 ----- 4.60	3.49 ----- 1.49	6.5	1	X	X	X	X	X
								A = Outside B = Inside	GOZ = Gold W = White Z = Black	MF = Mill Finish SA = Silver Anodised KL = Basic Colour HP = Special Colour M = Dual Colour			

Number	Picture	Page	Perim. mm	Mec. mm	Ix(cm4) wx(cm3)	Iy(cm4) wy(cm3)	Length	Pack pr.	MF	SA	KL	HP	M	
<b>ETC313</b>		A15	247	58	10.7 ----- 3.41	1.8 ----- 1.62	5	1	X	X	X	X	X	
<b>ETC316</b>		A15	363.7	258	26.24 ----- 6.86	3.71 ----- 1.60	6.5	1	X	X	X	X	X	
<b>ETC317</b>		A15	367.6	108	27.20 ----- 7.12	3.71 ----- 1.59	6.5	1	X	X	X	X	X	
<b>ETC420</b>		A16	299.7	76	11.21 ----- 3.94	2.50 ----- 1.06	6.5	1	X	X	X	X	X	
<b>ETC321</b>		A16	332	85	17.59 ----- 5.68	4.12 ----- 1.78	6.5	1	X	X	X	X	X	
<b>ETC323</b>		A16	401.51	108	12.38 ----- 3.44	3.09 ----- 1.34	6.5	1	X	X	X	X	X	
<b>ETC324</b>		A17	355.36	103	10.71 ----- 3.19	2.41 ----- 1.02	6.5	1	X	X	X	X	X	
<b>ETC326</b>		A17	342	77	14.90 ----- 3.87	3.40 ----- 1.49	6.5	1	X	X	X	X	X	
<b>ETC327</b>		A17	335	86	17.59 ----- 5.67	4.12 ----- 1.78	6.5	1	X	X	X	X	X	
								A = Outside B = Inside		GOZ = Gold W = White Z = Black		MF = Mill Finish SA = Silver Anodised KL = Basic Colour HP = Special Colour M = Dual Colour		

Number	Picture	Page	Perim. mm	Mec. mm	lx(cm4) wx(cm3)	ly(cm4) wy(cm3)	Length	Pack pr.	MF	SA	KL	HP	M		
<b>ETC328</b>		A18	<b>330</b>	85	15.1 ----- 5.31	4.15 ----- 1.82	6.5	1	X	X	X	X	X		
<b>ETC329</b>		A18	<b>343</b>	80	14.95 ----- 3.88	3.42 ----- 1.51	6.5	1	X	X	X	X	X		
<b>ETC333</b>		A19	<b>388.81</b>	54	<b>11.64</b> ----- 3.62	<b>2.63</b> ----- 1.09	6.5	1	X	X	X	X	X		
<b>ETC334</b>		A19	<b>382.97</b>	118	<b>28.7</b> ----- 6.73	<b>4.2</b> ----- 1.74	6.5	1	X	X	X	X	X		
<b>ETC335</b>		A19	<b>383</b>	97	15.06 ----- 5.25	5.56 ----- 1.92	6.5	1	X	X	X	X	X		
<b>ETC344</b>		A20	<b>246</b>	41	- ----- -	- ----- -	6.5	1	X	X	X	X	X		
<b>ETC345</b>		A20	<b>227</b>	41	- ----- -	- ----- -	6.5	1	X	X	X	X	X		
<b>ETC346</b>		A20	<b>242</b>	42	- ----- -	- ----- -	6.5	1	X	X	X	X	X		
<b>ETC347</b>		A25	<b>344.61</b>	94	<b>16.65</b> ----- 5.90	<b>16.65</b> ----- 6.11	6.5	1	X	X	X	X	X		
								A = Outside B = Inside		GOZ = Gold W = White Z = Black		MF = Mill Finish SA = Silver Anodised KL = Basic Colour HP = Special Colour M = Dual Colour			

Number	Picture	Page	Perim. mm	Mec. mm	lx(cm4) wx(cm3)	ly(cm4) wy(cm3)	Length	Pack pr.	MF	SA	KL	HP	M	
ETC348		A25	438.46	140	54.66 ----- 13.88	54.66 ----- 13.98	6.5	1	X	X	X	X	X	
ETC350		A26	322.11	31	- ----- -	- ----- -	6.5	1	X	X	X	X	X	
ETC353		A26	214.38	32	9.44 ----- 3.56	1.15 ----- 0.85	6.5	1	X	X	X	X	X	
ETC357		A27	297.69	72	41.5 ----- 9.86	5.2 ----- 2.67	6.5	1	X	X	X	X	X	
ETC358		A27	264.12	33	12.95 ----- 4.89	4.74 ----- 2.61	6.5	1	X	X	X	X	X	
ETC359		A28	318.44	40.92	19.6 ----- 5.16	1.2 ----- 0.98	6.5	1	X	X	X	X	X	
ETC364		A21	122.37	28	- ----- -	- ----- -	6.5	1	X	X	X	X		
ETC366		A22	106	24	- ----- -	- ----- -	6.5	1	X	X	X	X		
ETC367		A21 & A22	89.44	33	- ----- -	- ----- -	6.5	1	X	X	X	X		
								A = Outside B = Inside		GOZ = Gold W = White Z = Black		MF = Mill Finish SA = Silver Anodised KL = Basic Colour HP = Special Colour M = Dual Colour		

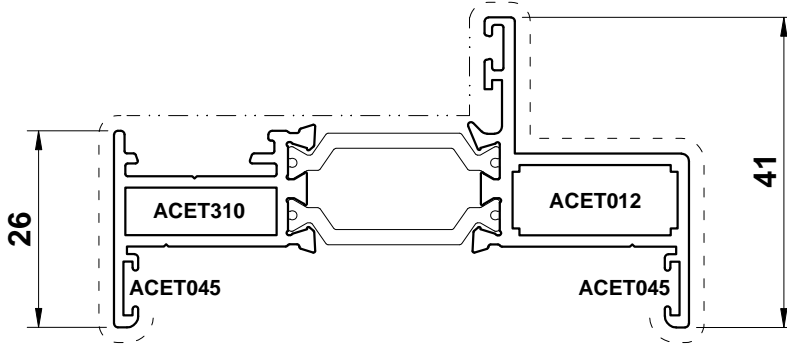
Number	Picture	Page	Perim. mm	Mec. mm	lx(cm4) wx(cm3)	ly(cm4) wy(cm3)	Length	Pack pr.	MF	SA	KL	HP	M		
ETC370		A21	140.93	32	- ----- -	- ----- -	6.5	1	X	X	X	X			
ETC371		A22	132.93	28	- ----- -	- ----- -	6.5	1	X	X	X	X			
ETC372		A20	96	22	- ----- -	- ----- -	6.5	1	X	X	X	X			
ETC373		A20	102	25	- ----- -	- ----- -	6.5	1	X	X	X	X			
ETC374		A21	97	37	- ----- -	- ----- -	6.5	1	X	X	X	X			
ETC375		A22	112	22	- ----- -	- ----- -	6.5	1	X	X	X	X			
ETC515		A29	353.60	102	30.12 ----- 7.96	12.75 ----- 6.00	6.5	1	X	X	X	X	X		
ETC869		A28	311.56	144	18.38 ----- 6.13	14.30 ----- 5.17	6.5	1	X	X	X	X	X		
ETD351		A29	99.36	16	- ----- -	- ----- -	6.5	X	X	X	X	X			
								A = Outside B = Inside		GOZ = Gold W = White Z = Black		MF = Mill Finish SA = Silver Anodised KL = Basic Colour HP = Special Colour M = Dual Colour			

Number	Picture	Page	Perim. mm	Mec. mm	lx(cm4) wx(cm3)	ly(cm4) wy(cm3)	Length	Pack pr.	MF	SA	KL	HP	M
<b>UTL039</b>		A29	42.75	42.75	- ----- -	- ----- -	6	X	X	X	X	X	
<b>ETD330</b>	 A & B may be reversed	A30	<b>545.32</b>	197	<b>28.40</b> ----- 10.55	<b>56.92</b> ----- 10.44	6.5	X	X	X	X	X	X
<b>VL72</b>		A29	100.9	31.7	- ----- -	- ----- -	6.5	5	X	X	X	X	
									A = Outside B = Inside	GOZ = Gold W = White Z = Black	MF = Mill Finish SA = Silver Anodised KL = Basic Colour HP = Special Colour M = Dual Colour		

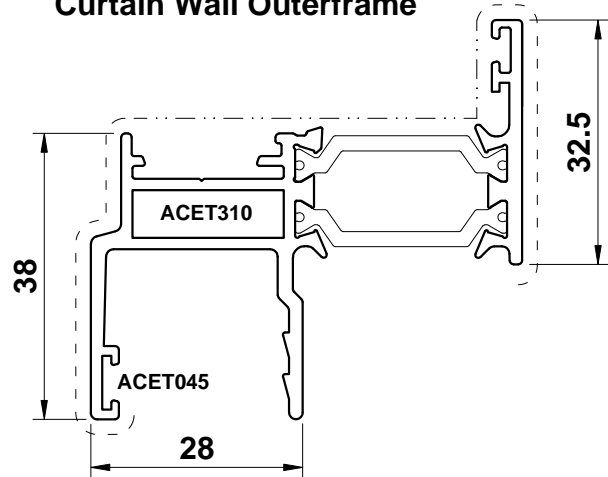
Primary Visible Side

Secondary Visible Side

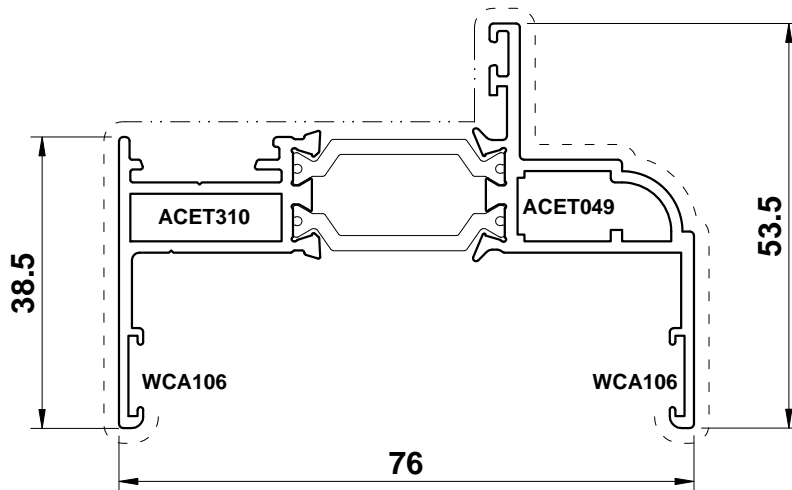
**ETC307**  
Short Leg Square Outerframe



**ETC308**  
Curtain Wall Outerframe



**ETC309**  
Long Leg Ovolo Outerframe

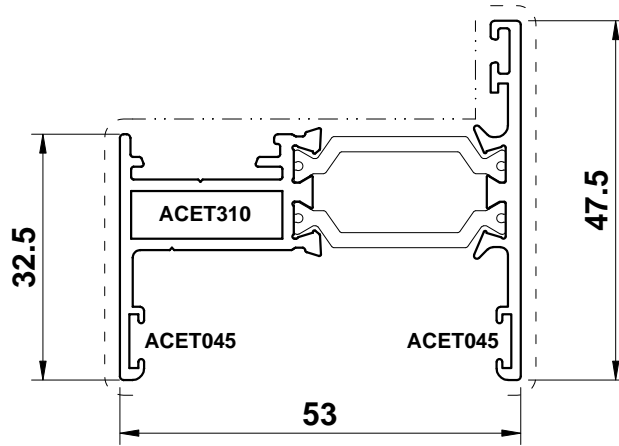


Scale 1:1

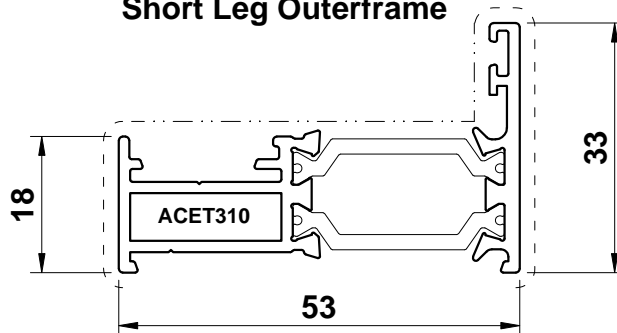
Primary Visible Side

Secondary Visible Side

**ETC310**  
Long Leg Outerframe



**ETC313**  
Short Leg Outerframe



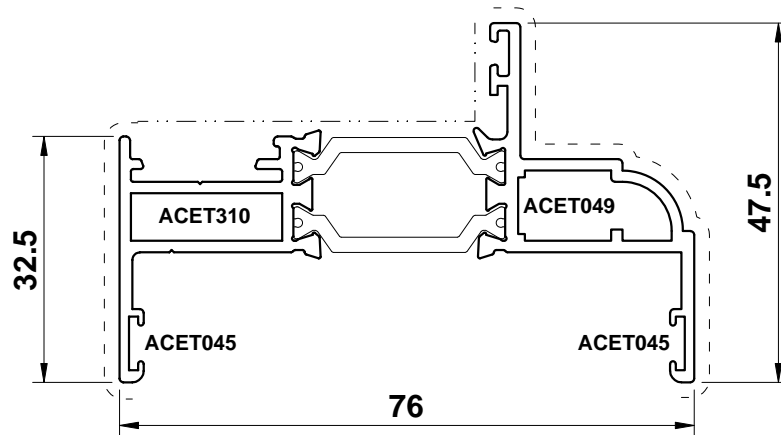
Scale 1:1



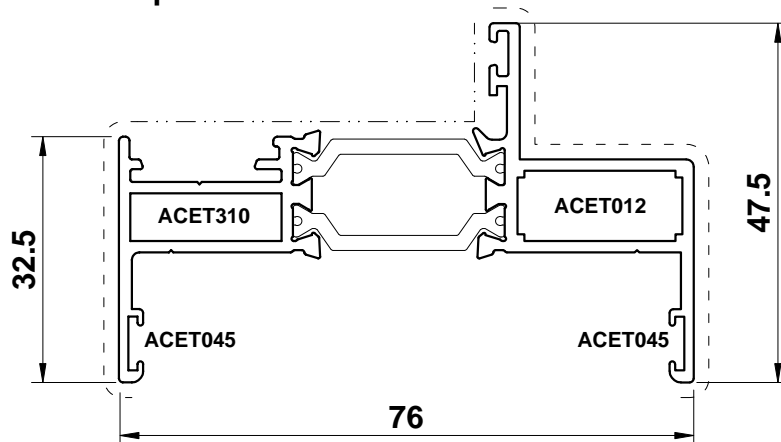
Primary Visible Side

Secondary Visible Side

**ETC316**  
Ovolo Outerframe



**ETC317**  
Square Outerframe



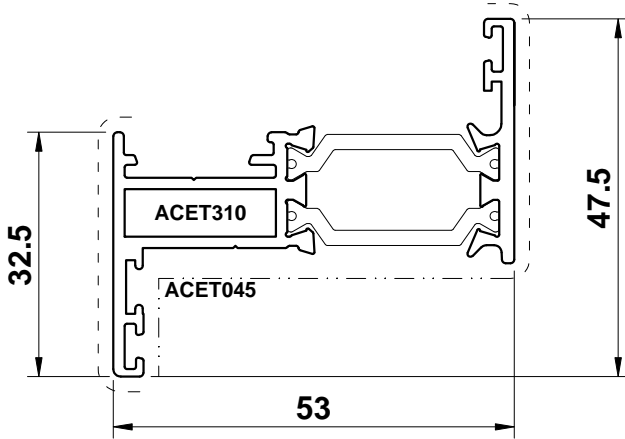
Scale 1:1

Primary Visible Side

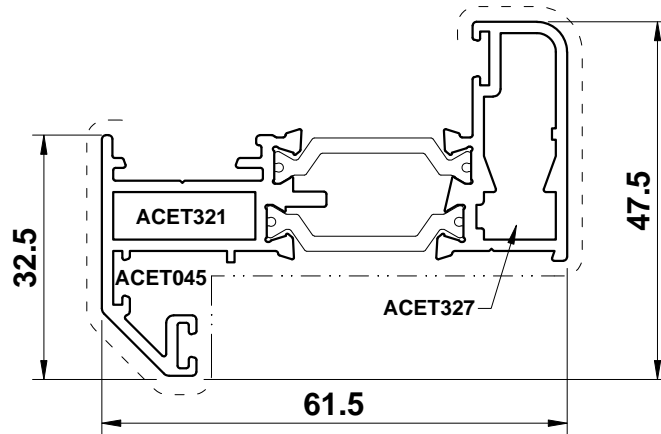
Secondary Visible Side

**ETC420**

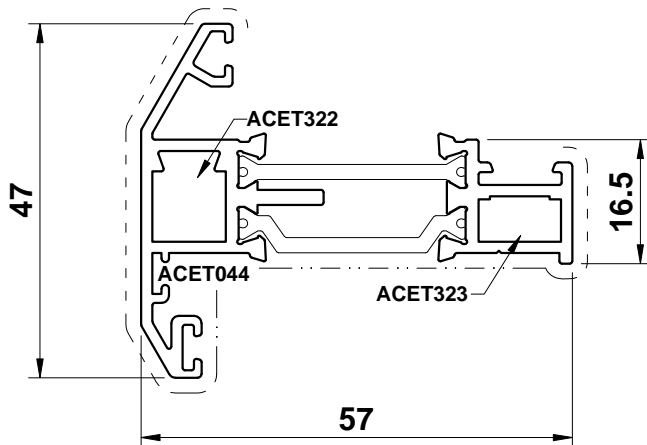
Vent (Cockspur Locking Only)  
/Odd Leg Outerframe



**ETC321**  
Chamfered Vent



**ETC323**  
Chamfered Vent



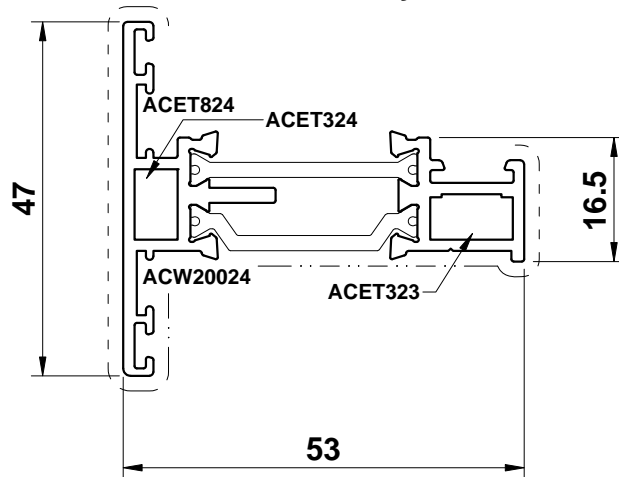
Scale 1:1

Primary Visible Side

Secondary Visible Side

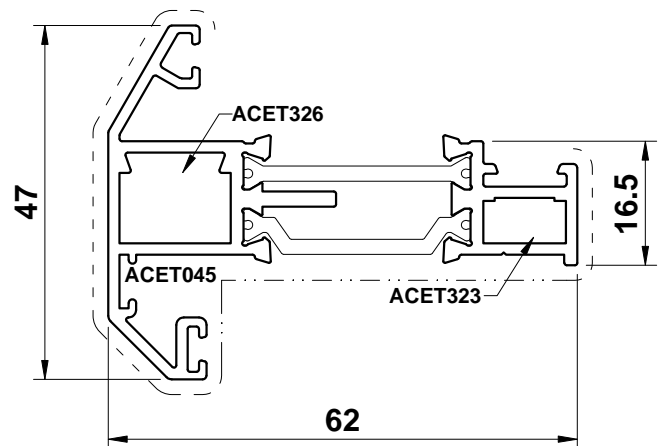
### ETC324

Vent / Dummy Vent



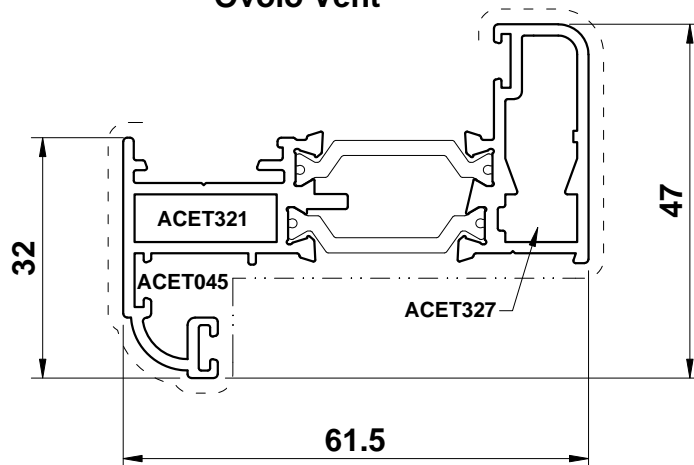
### ETC326

Chamfered Vent



### ETC327

Ovolo Vent

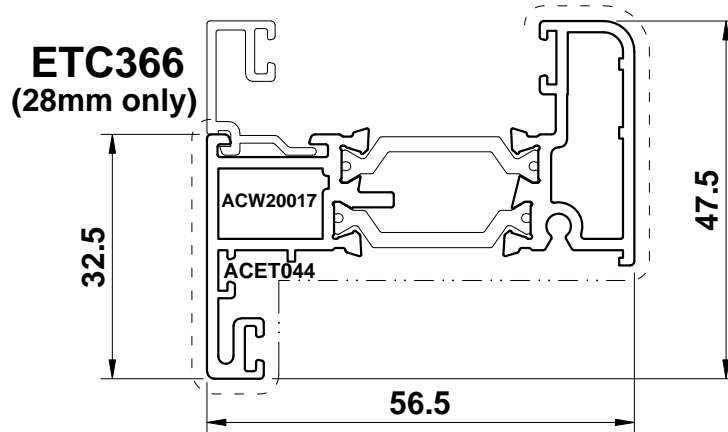


Scale 1:1

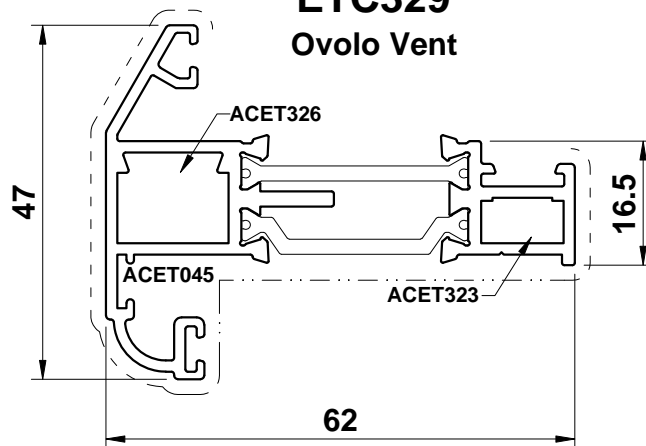
Primary Visible Side

Secondary Visible Side

**ETC328**  
Vent



**ETC329**  
Ovolo Vent



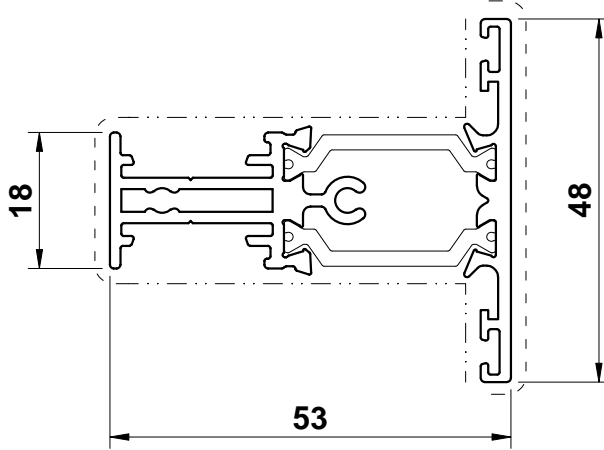
Scale 1:1

Primary Visible Side

Secondary Visible Side

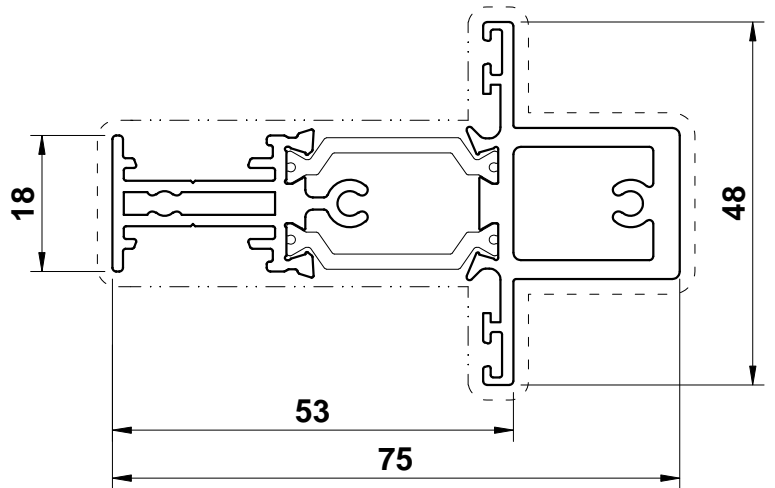
**ETC333**

**Transom / Mullion with Screwports**



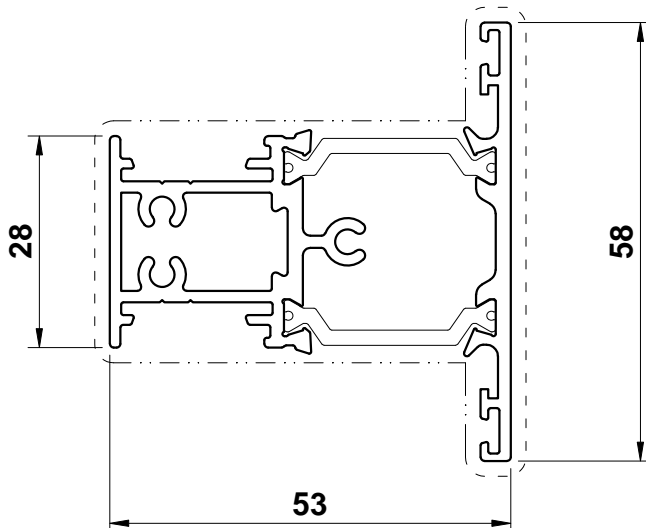
**ETC334**

**Reinforced Transom / Mullion with Screwports**



**ETC335**

**Wide Transom / Mullion with Screwports**

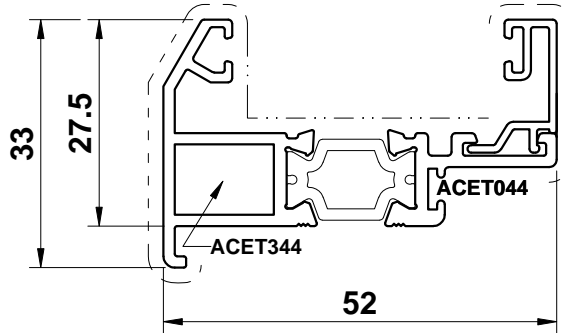


Scale 1:1

Primary Visible Side

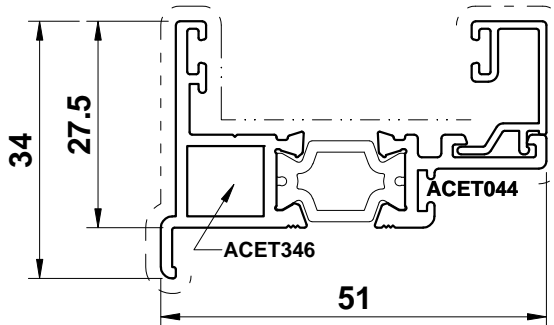
Secondary Visible Side

**ETC344**  
Dummy Vent



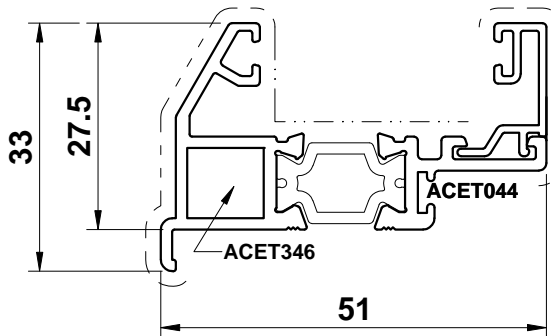
**ETC372**  
(28mm Glazing)

**ETC345**  
Dummy Vent



**ETC373**  
(28mm Glazing)

**ETC346**  
Dummy Vent



**ETC372**  
(24mm Glazing)

Scale 1:1

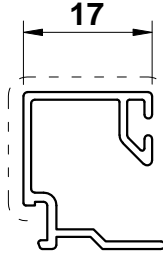
Primary Visible Side

Secondary Visible Side

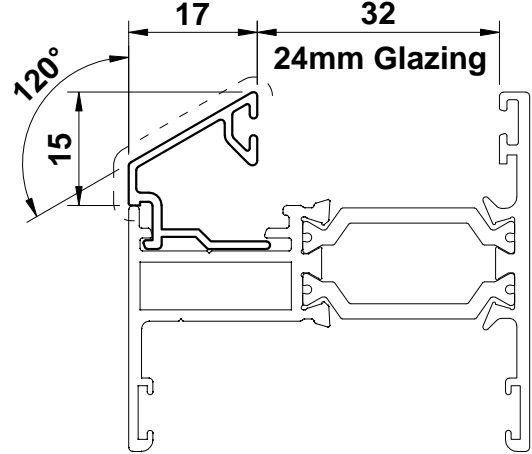
**24mm Glazing  
External**

ETC307 ETC420  
ETC308 ETC321  
ETC309 ETC327  
ETC310 ETC333  
ETC313 ETC334  
ETC316 ETC335  
ETC317

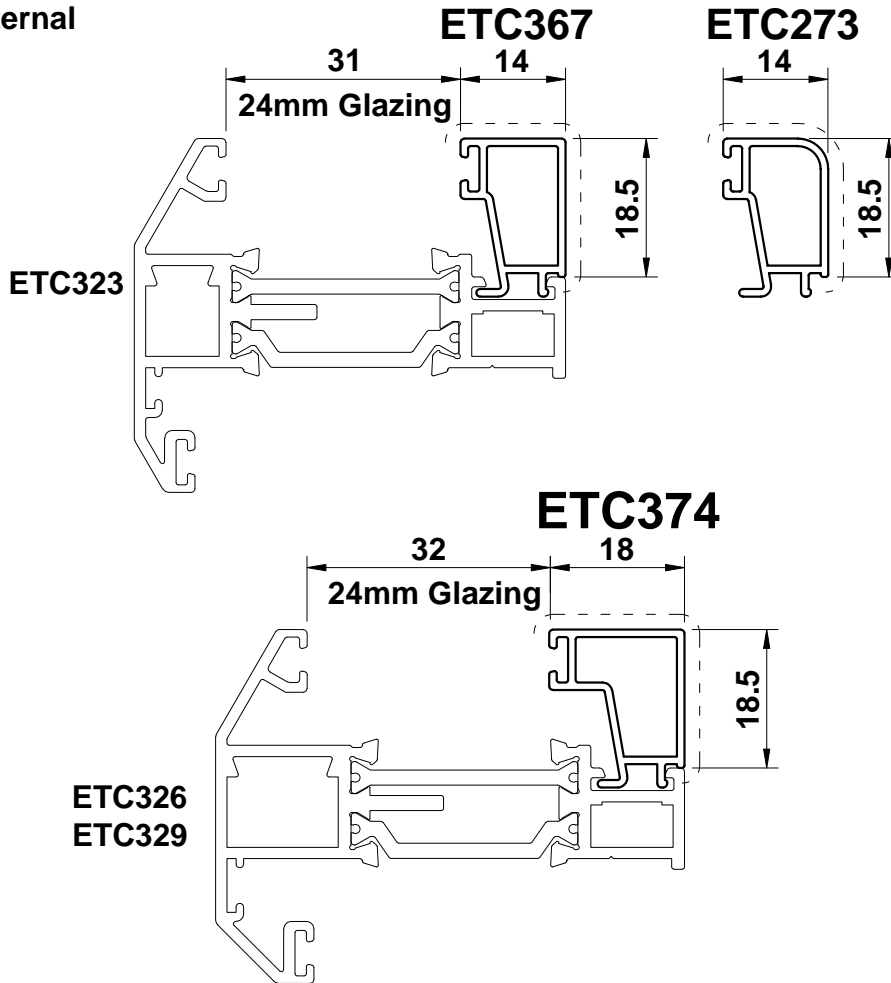
**ETC370**



**ETC364**



**24mm Glazing  
Internal**



**See Page E15 for Glazing Schedule**

Scale 1:1

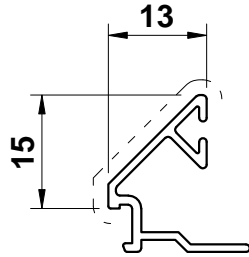
Primary Visible Side

Secondary Visible Side

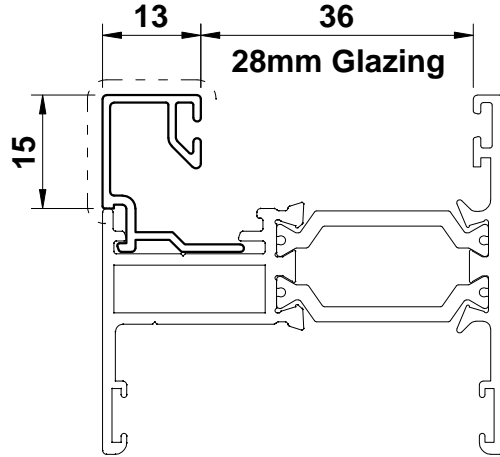
**28mm Glazing  
External**

- ETC307 ETC420
- ETC308 ETC321
- ETC309 ETC327
- ETC310 ETC333
- ETC313 ETC334
- ETC316 ETC335
- ETC317

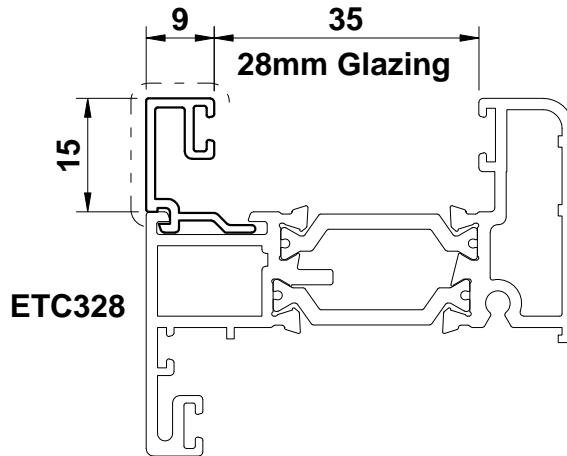
**ETC375**



**ETC371**



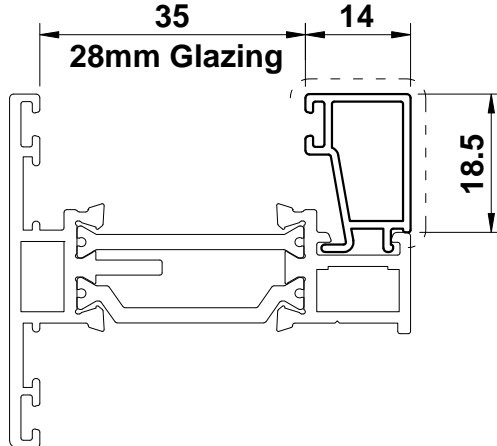
**ETC366**



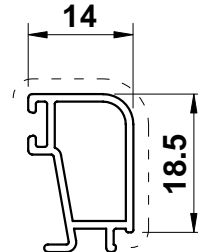
**28mm Glazing  
Internal**

- ETC324
- ETC326
- ETC329

**ETC367**



**ETC273**



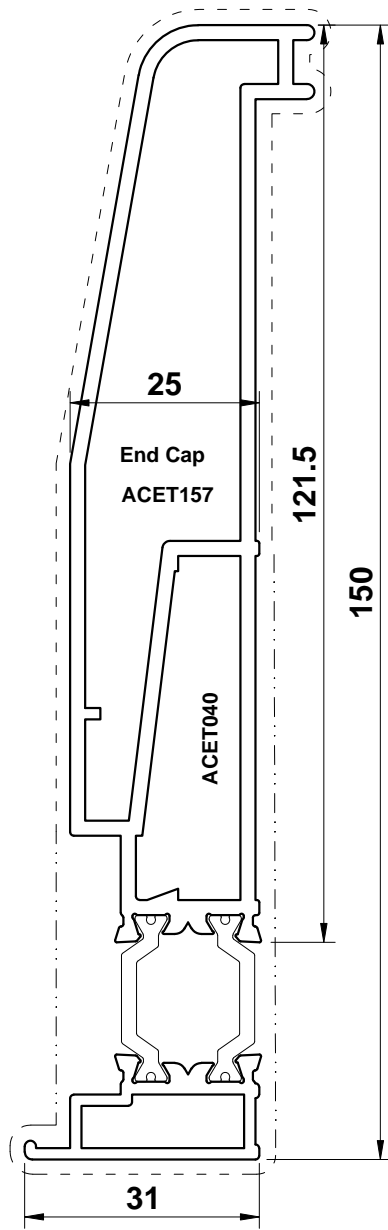
**See Page E16 for Glazing Schedule**

Scale 1:1

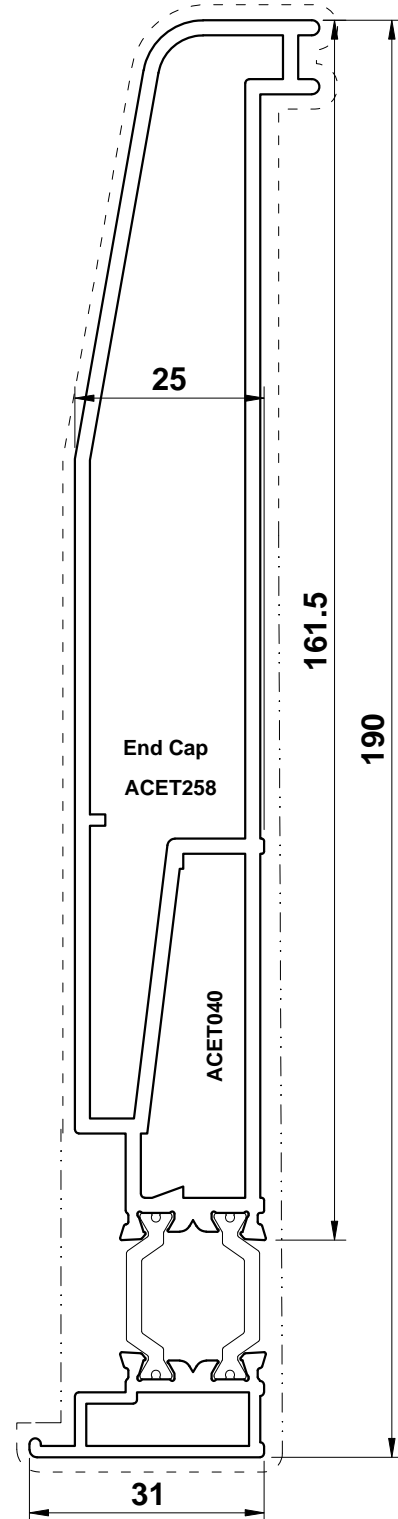


Primary Visible Side

Secondary Visible Side



**ETC157**  
150mm Cill

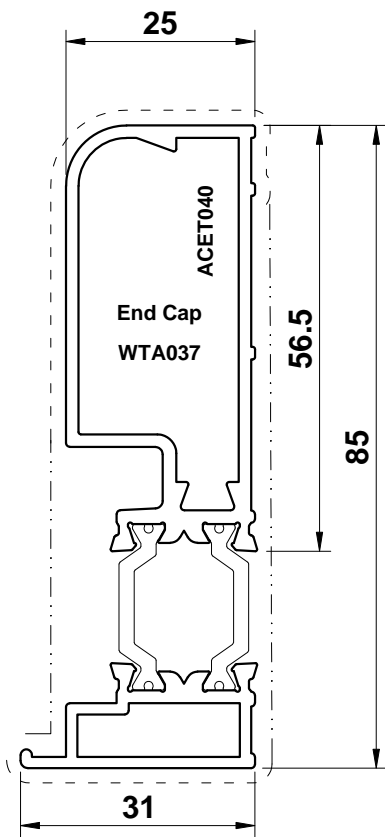


**ETC158**  
190mm Cill

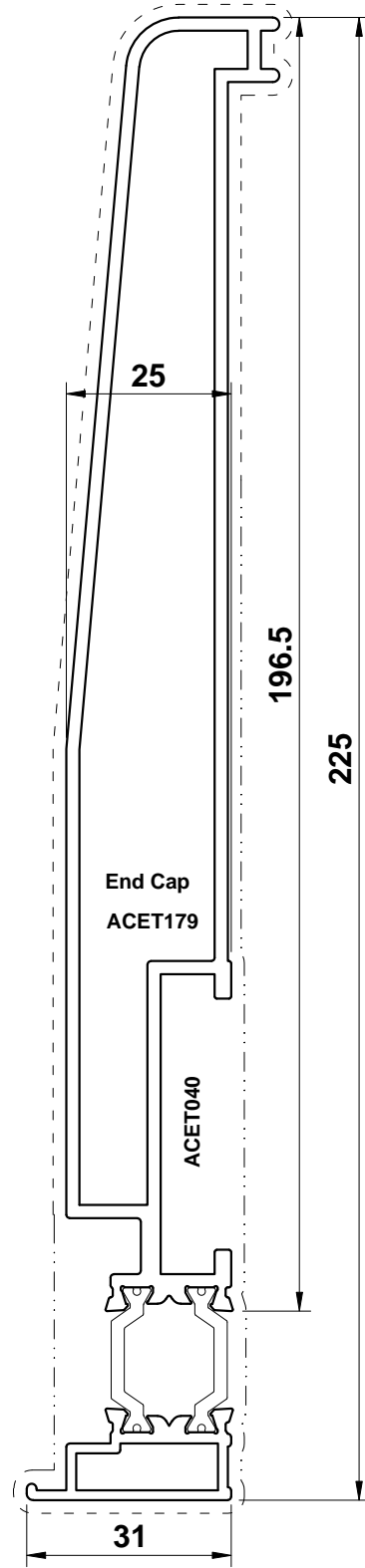
Scale 1:1

Primary Visible Side

Secondary Visible Side



**ETC178**  
85mm Cill



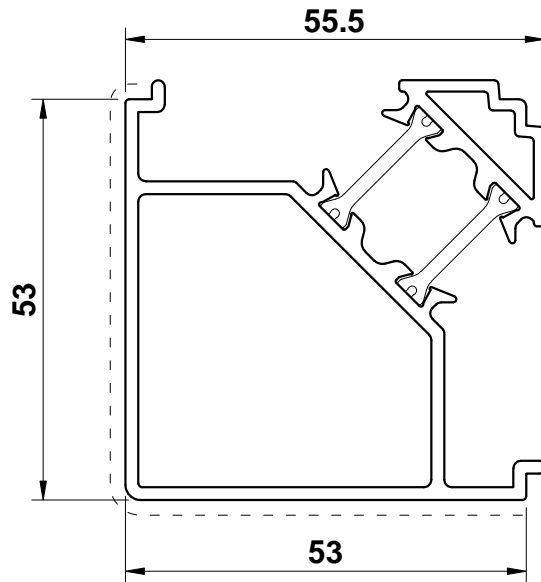
**ETC179**  
NB: This Profile Only -  
REDUCED SCALE TO FIT  
225mm Cill

Scale 1:1

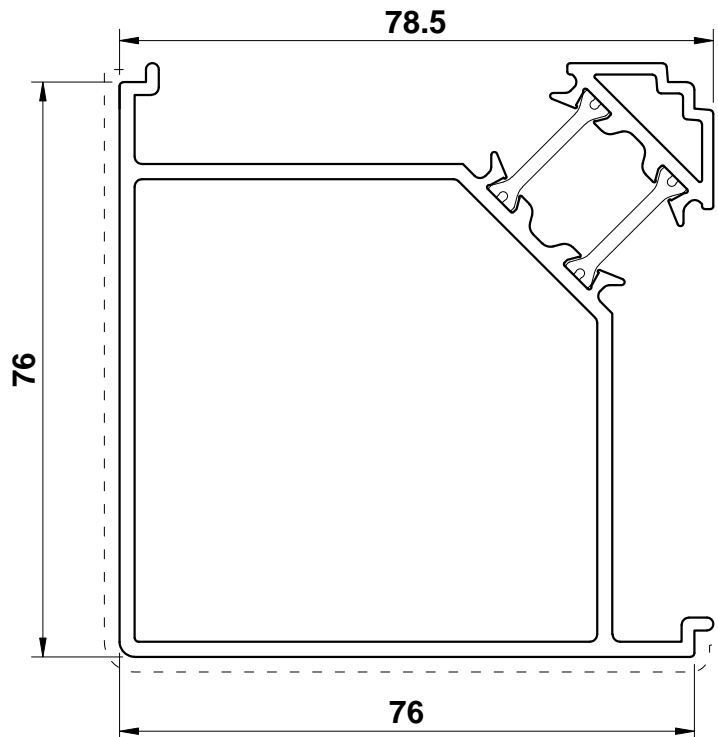
Primary Visible Side

Secondary Visible Side

**ETC347**  
90° Corner Post



**ETC348**  
90° Corner Post

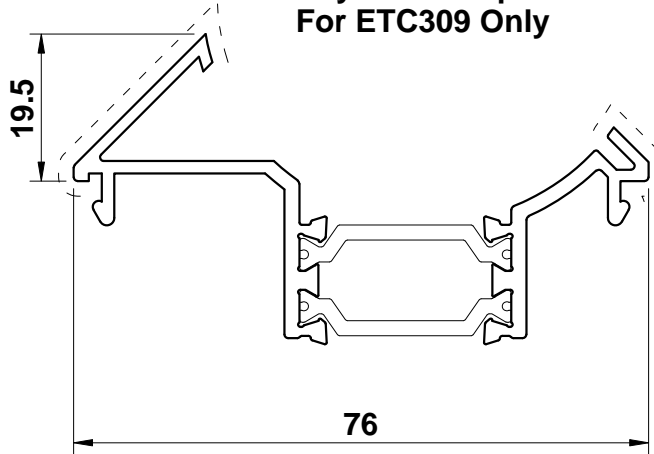


Scale 1:1

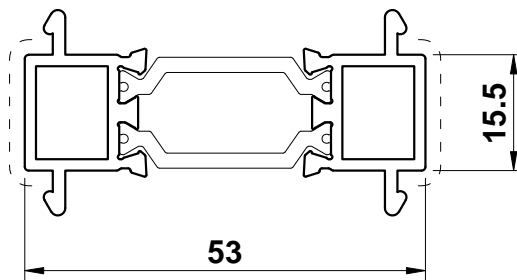
Primary Visible Side

Secondary Visible Side

**ETC350**  
Bay Pole Adaptor  
For ETC309 Only



**ETC353**  
Coupler

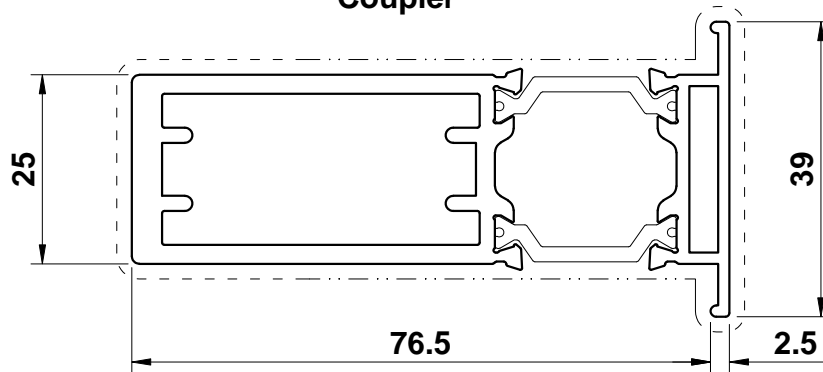


Scale 1:1

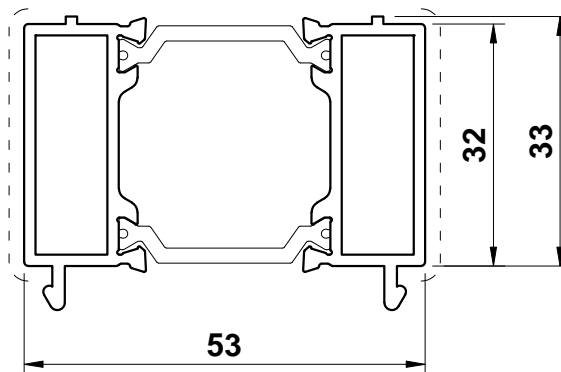
Primary Visible Side

Secondary Visible Side

**ETC357**  
Coupler



**ETC358**  
Head Extension

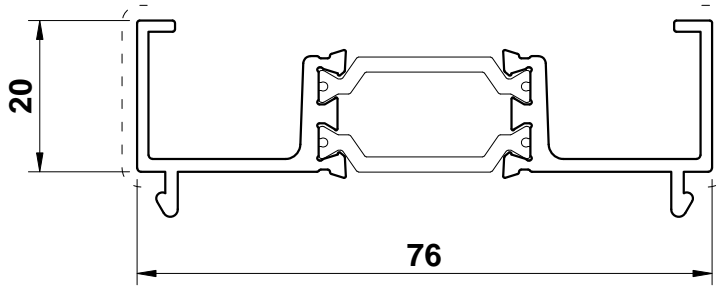


Scale 1:1

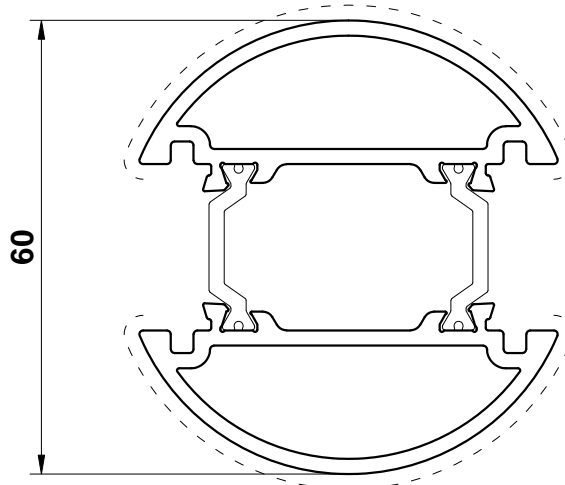
Primary Visible Side

Secondary Visible Side

**ETC359**  
Frame Extension



**ETC869**  
Bay Pole

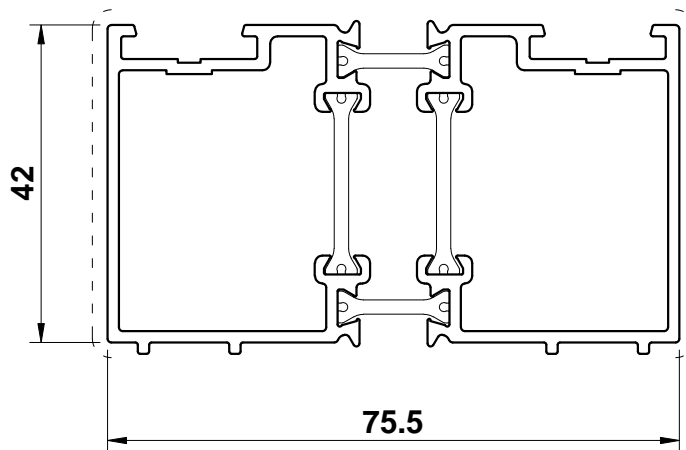


Scale 1:1

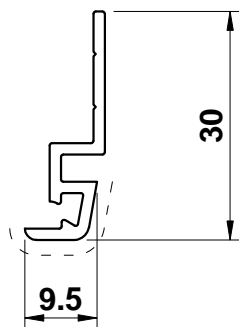
Primary Visible Side

Secondary Visible Side

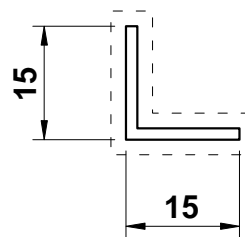
**ETC515**  
Head Extension



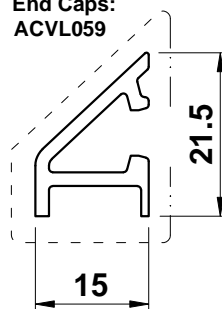
**ETD351**  
Coupler  
(see E18)



**UTL039**



**VL72**  
End Caps:  
ACVL059

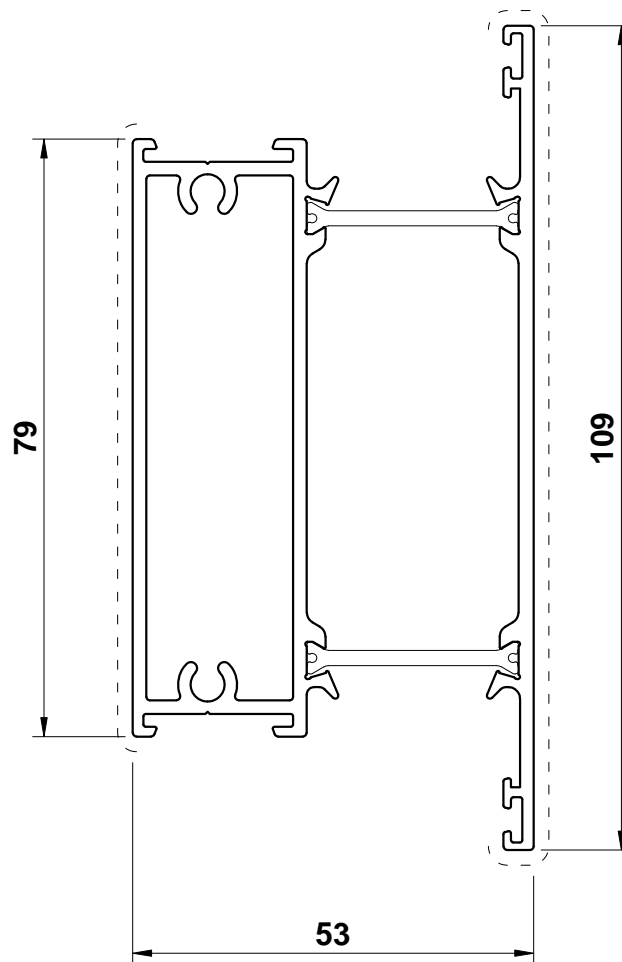


Scale 1:1

Primary Visible Side

Secondary Visible Side

**ETD330**  
Transom to match ETD030  
(Recommended for fixed lights only)



ETD330 can be used with the outerframes shown in this manual providing the following beads & gasket are used in the midrail:  
24mm = ETC362 with ACET841 gasket externally & ACW20034 gasket internally  
28mm = ETC361 with ACET841 gasket externally & ACW20034 gasket internally

ETD330 is recommended for fixed lights only. The friction hinges and keeps in this manual are not compatible with this section as standard.

Scale 1:1



**Section B**

Image	Part Code	Pack	Unit	Application	Colour
	<b>ACDR052</b>  <b>No. 10 x 50 S/S Self Tapping Pan Head Screw</b>	<b>200</b>	<b>pack</b>	<b>ETC348</b>	MF
					SA
					KL
					HP
					M
					GOZ
					PC
					W
Z					
	<b>ACET824</b>  <b>Chevron</b>	<b>24</b>	<b>pack</b>	<b>ETC324</b>	MF
					SA
					KL
					HP
					M
					GOZ
					PC
					W
Z					
	<b>ACET040</b>  <b>Variable Angle Cill Joiner</b>  <b>Drill Jig = HEJ050</b> <b>Screws = HEA18SSZ</b>	<b>10</b>	<b>pack</b>	<b>ETC157</b> <b>ETC158</b> <b>ETC178</b> <b>ETC179</b>	MF
					SA
					KL
					HP
					M
					GOZ
					PC
					W
Z					
	<b>ACET041</b>  <b>Cill Nose Bracket</b>	<b>1</b>	<b>each</b>	<b>ETC157</b> <b>ETC158</b> <b>ETC179</b>	MF
					SA
					KL
					HP
					M
					GOZ
					PC
					W
Z					
	<b>ACET044</b>  <b>Stainless Steel Chevron</b>	<b>100</b>	<b>pack</b>	<b>ETC323</b> <b>ETC326</b> <b>ETC329</b> <b>ETC344</b> <b>ETC345</b> <b>ETC346</b>	MF
					SA
					KL
					HP
					M
					GOZ
					PC
					W
Z					
<table border="1"> <tr> <td>T-BARS ACVG65=2.5mm ACVG66=3.0mm ACVL150=4.0mm</td> <td>Screw (Grub)</td> </tr> </table>	T-BARS ACVG65=2.5mm ACVG66=3.0mm ACVL150=4.0mm	Screw (Grub)	<b>MF = Mill Finish</b> <b>SA = Silver Anodised</b> <b>KL = Basic Colour</b> <b>HP = Special Colour</b> <b>M = Dual Colour</b>	<b>GOZ = Gold</b> <b>PC = Polished Chrome</b> <b>W = White</b> <b>Z = Black</b>	
T-BARS ACVG65=2.5mm ACVG66=3.0mm ACVL150=4.0mm	Screw (Grub)				

Image	Part Code	Pack	Unit	Application	Colour
	<b>ACET045</b>  <b>Stainless Steel Chevron</b>	<b>100</b>	<b>pack</b>	<b>ETC310</b> <b>ETC420</b> <b>ETC321</b> <b>ETC327</b>	MF
					SA
					KL
					HP
					M
					GOZ
					PC
					W
					Z
	<b>ACET049</b>  <b>Corner Cleat</b>	<b>10</b>	<b>pack</b>	<b>ETC309</b> <b>ETC316</b>	MF
					SA
					KL
					HP
					M
					GOZ
					PC
					W
					Z
	<b>ACET060</b>  <b>No. 7 x 25 S/S Self Tapping CSK Screw</b>	<b>100</b>	<b>pack</b>	<b>ETC328</b>	MF
					SA
					KL
					HP
					M
					GOZ
					PC
					W
					Z
	<b>ACET062</b>  <b>No. 10 x 50 S/S Self Tapping CSK Screw</b>	<b>100</b>	<b>pack</b>	<b>ETC347</b>	MF
					SA
					KL
					HP
					M
					GOZ
					PC
					W
					Z
	<b>ACET064</b>  <b>No. 8 x 16 S/S Self Tapping Pan Head Screw</b>	<b>100</b>	<b>pack</b>	<b>Friction Hinges</b>	MF
					SA
					KL
					HP
					M
					GOZ
					PC
					W
					Z
<small>T-BARS ACVG65=2.5mm ACVG66=3.0mm ACVL150=4.0mm</small>	<small>Screw (Grub)</small>	<b>MF = Mill Finish</b> <b>SA = Silver Anodised</b> <b>KL = Basic Colour</b> <b>HP = Special Colour</b> <b>M = Dual Colour</b>		<b>GOZ = Gold</b> <b>PC = Polished Chrome</b> <b>W = White</b> <b>Z = Black</b>	





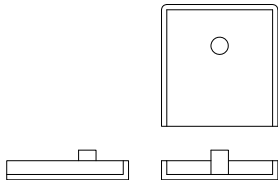


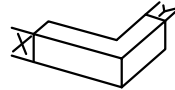
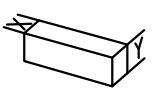
Image	Part Code	Pack	Unit	Application	Colour
	<b>ACET066</b>  <b>No. 7 x 38 S/S Self Tapping CSK Screw</b>	<b>100</b>	<b>pack</b>	<b>ETC331</b> <b>ETC333</b> <b>ETD330</b>	MF
					SA
					KL
					HP
					M
					GOZ
					PC
					W
Z					
	<b>ACET068</b>  <b>No. 8 x 10 S/S Self Tapping Flange Screw</b>	<b>100</b>	<b>pack</b>	<b>Friction Hinges</b>	MF
					SA
					KL
					HP
					M
					GOZ
					PC
					W
Z					
	<b>ACET069</b>  <b>M5 x 12 S/S CSK Machine Screw</b>	<b>100</b>	<b>pack</b>	<b>ACET165</b>	MF
					SA
					KL
					HP
					M
					GOZ
					PC
					W
Z					
	<b>ACET070</b>  <b>No. 8 x 13 S/S Self Tapping Flange Screw</b>	<b>100</b>	<b>pack</b>	<b>Friction Hinges</b> <b>ETD351</b>	MF
					SA
					KL
					HP
					M
					GOZ
					PC
					W
Z					
	<b>ACET075</b>  <b>End Cap</b>	<b>50</b>	<b>pack</b>	<b>ETC334</b>	MF
					SA
					KL
					HP
					M
					GOZ
					PC
					W
Z	X				
	T-BARS ACVG65=2.5mm ACVG66=3.0mm ACVL150=4.0mm		<b>MF = Mill Finish</b> <b>GOZ = Gold</b> <b>SA = Silver Anodised</b> <b>PC = Polished Chrome</b> <b>KL = Basic Colour</b> <b>W = White</b> <b>HP = Special Colour</b> <b>Z = Black</b> <b>M = Dual Colour</b>		 

Image	Part Code	Pack	Unit	Application	Colour	
	<b>ACET080</b>  <b>Cockspur Handle</b>	<b>1</b>	<b>each</b>	<b>ACET083</b>	MF	
					SA	X
					KL	
					HP	
					M	
					GOZ	X
					PC	
					W	X
					Z	X
	<b>ACET083</b>  <b>3mm Wedge</b>	<b>100</b>	<b>pack</b>	<b>ACET080</b>	MF	
					SA	
					KL	
					HP	
					M	
					GOZ	
					PC	
					W	X
					Z	X
	<b>ACET093</b>  <b>Packers</b>	<b>25</b>	<b>pack</b>	<b>ETC344</b> <b>ETC345</b> <b>ETC346</b>	MF	
					SA	
					KL	
					HP	
					M	
					GOZ	
					PC	
					W	
					Z	X
	<b>ACET099</b>  <b>No. 8 x 19 S/S Self Tapping Flange Screw</b>	<b>100</b>	<b>pack</b>	<b>Friction Hinges</b>	MF	
					SA	
					KL	
					HP	
					M	
					GOZ	
					PC	
					W	
					Z	
	<b>ACET114</b>  <b>Anti-Twist Clip</b>	<b>100</b>	<b>pack</b>	<b>ETC333</b> <b>ETC334</b>	MF	
					SA	
					KL	
					HP	
					M	
					GOZ	
					PC	
					W	
					Z	
<small>T-BARS ACVG65=2.5mm ACVG66=3.0mm ACVL150=4.0mm</small>	<small>Screw (Grub)</small>	<b>MF = Mill Finish</b> <b>SA = Silver Anodised</b> <b>KL = Basic Colour</b> <b>HP = Special Colour</b> <b>M = Dual Colour</b>		<b>GOZ = Gold</b> <b>PC = Polished Chrome</b> <b>W = White</b> <b>Z = Black</b>		


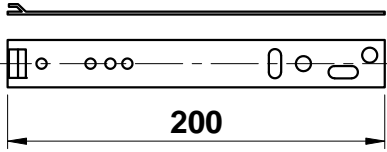


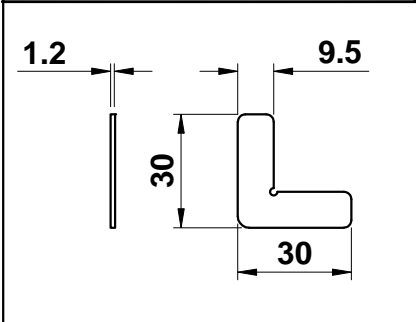
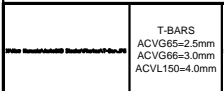

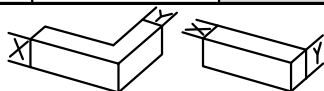
Image	Part Code	Pack	Unit	Application	Colour	
	<b>ACET125</b>  <b>Anti-Twist Clip</b>	<b>100</b>	<b>pack</b>	<b>ETC335</b>	MF	
					SA	
					KL	
					HP	
					M	
					GOZ	
					PC	
					W	
Z						
	<b>ACET130</b>  <b>Galvanised Steel Fixing Strap</b>  <b>200mm x 25mm x 1.5mm</b>	<b>50</b>	<b>pack</b>	<b>ETC307</b> <b>ETC309</b> <b>ETC310</b> <b>ETC313</b> <b>ETC316</b> <b>ETC317</b>	MF	
					SA	
					KL	
					HP	
					M	
					GOZ	
					PC	
					W	
Z						
	<b>ACET131</b>  <b>Drainage Cover Cap</b>	<b>100</b>	<b>pack</b>		MF	
					SA	
					KL	
					HP	
					M	
					GOZ	
					PC	
					W	X
Z	X					
	<b>ACET165</b>  <b>Espagnolette Handle</b> <b>9mm Spindle</b>	<b>1</b>	<b>each</b>	<b>Shootbolt Locking</b>	MF	
					SA	X
					KL	
					HP	
					M	
					GOZ	
					PC	
					W	X
Z	X					
	<b>ACET171</b>  <b>Stainless Steel Chevron</b>	<b>100</b>	<b>pack</b>	<b>ETC324</b>	MF	
					SA	
					KL	
					HP	
					M	
					GOZ	
					PC	
					W	
Z						
	T-BARS ACVG65=2.5mm ACVG66=3.0mm ACVL150=4.0mm		<b>MF = Mill Finish</b> <b>GOZ = Gold</b> <b>SA = Silver Anodised</b> <b>PC = Polished Chrome</b> <b>KL = Basic Colour</b> <b>W = White</b> <b>HP = Special Colour</b> <b>Z = Black</b> <b>M = Dual Colour</b>			

Image	Part Code	Pack	Unit	Application	Colour	
	<b>ACET157</b>  <b>Cill End Cap</b>	<b>10</b>	<b>pair</b>	<b>ETC157</b>	MF	
					SA	
					KL	
					HP	
					M	
					GOZ	
					PC	
					W	X
					Z	X
	<b>ACET179</b>  <b>Cill End Cap</b>	<b>10</b>	<b>pair</b>	<b>ETC179</b>	MF	
					SA	
					KL	
					HP	
					M	
					GOZ	
					PC	
					W	X
					Z	X
	<b>ACET258</b>  <b>Cill End Cap</b>	<b>10</b>	<b>pair</b>	<b>ETC158</b>	MF	
					SA	
					KL	
					HP	
					M	
					GOZ	
					PC	
					W	X
					Z	X
	<b>ACET310</b>  <b>Corner Cleat</b>	<b>24</b>	<b>pack</b>	<b>ETC307</b> <b>ETC308</b> <b>ETC309</b> <b>ETC310</b> <b>ETC313</b> <b>ETC316</b> <b>ETC317</b>	MF	
					SA	
					KL	
					HP	
					M	
					GOZ	
					PC	
					W	X
					Z	X
	<b>ACET311</b>  <b>Stainless Steel Chevron</b>	<b>50</b>	<b>pack</b>	<b>ETC311</b>	MF	
					SA	
					KL	
					HP	
					M	
					GOZ	
					PC	
					W	X
					Z	X
	T-BARS ACVG65=2.5mm ACVG66=3.0mm ACVL150=4.0mm		<b>MF = Mill Finish</b> <b>SA = Silver Anodised</b> <b>KL = Basic Colour</b> <b>HP = Special Colour</b> <b>M = Dual Colour</b>		<b>GOZ = Gold</b> <b>PC = Polished Chrome</b> <b>W = White</b> <b>Z = Black</b>	

Image	Part Code	Pack	Unit	Application	Colour	
	<b>ACET312</b>  <b>Foam Infill</b> <b>1250mm Lengths</b>	1	each	ETC310	MF	
					SA	
					KL	
					HP	
					M	
					GOZ	
					PC	
					W	
					Z	
	<b>ACET314</b>  <b>Foam Infill</b> <b>1250mm Lengths</b>	1	each	ETC307	MF	
					SA	
					KL	
					HP	
					M	
					GOZ	
					PC	
					W	
					Z	
	<b>ACET315</b>  <b>Foam Infill</b> <b>1250mm Lengths</b>	1	each	ETC309	MF	
					SA	
					KL	
					HP	
					M	
					GOZ	
					PC	
					W	
					Z	
	<b>ACET319</b>  <b>Foam Infill</b> <b>1250mm Lengths</b>	1	each	ETC316 ETC317	MF	
					SA	
					KL	
					HP	
					M	
					GOZ	
					PC	
					W	
					Z	
	<b>ACET321</b>  <b>Outer Corner Cleat</b>	24	pack	ETC321 ETC327	MF	
					SA	
					KL	
					HP	
					M	
					GOZ	
					PC	
					W	
					Z	
	T-BARS ACVG65=2.5mm ACVG66=3.0mm ACVL150=4.0mm		MF = Mill Finish SA = Silver Anodised KL = Basic Colour HP = Special Colour M = Dual Colour GOZ = Gold PC = Polished Chrome W = White Z = Black			



Image	Part Code	Pack	Unit	Application	Colour		
	<b>ACET322</b>  <b>Outer Corner Cleat</b>	24	pack	<b>ETC323</b> <b>ETC345</b> <b>ETC346</b>	MF SA KL HP M GOZ PC W Z		
	<b>ACET323</b>  <b>Inner Corner Cleat</b>	24	pack	<b>ETC323</b> <b>ETC324</b> <b>ETC326</b> <b>ETC329</b>	MF SA KL HP M GOZ PC W Z		
	<b>ACET324</b>  <b>Outer Corner Cleat</b>	24	pack	<b>ETC324</b>	MF SA KL HP M GOZ PC W Z		
	<b>ACET326</b>  <b>Corner Cleat</b>	24	pack	<b>ETC326</b> <b>ETC329</b>	MF SA KL HP M GOZ PC W Z		
	<b>ACET327</b>  <b>Inner Corner Cleat</b>	24	pack	<b>ETC321</b> <b>ETC327</b>	MF SA KL HP M GOZ PC W Z		
<table border="1"> <tr> <td>T-BARS ACVG65=2.5mm ACVG66=3.0mm ACVL150=4.0mm</td> <td>Screw (Grub)</td> </tr> </table>	T-BARS ACVG65=2.5mm ACVG66=3.0mm ACVL150=4.0mm	Screw (Grub)	<b>MF = Mill Finish</b> <b>SA = Silver Anodised</b> <b>KL = Basic Colour</b> <b>HP = Special Colour</b> <b>M = Dual Colour</b>	<b>GOZ = Gold</b> <b>PC = Polished Chrome</b> <b>W = White</b> <b>Z = Black</b>			
T-BARS ACVG65=2.5mm ACVG66=3.0mm ACVL150=4.0mm	Screw (Grub)						

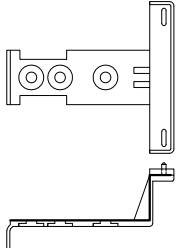
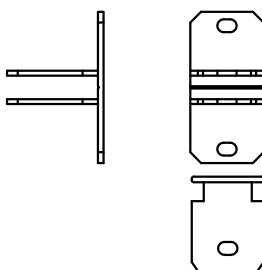
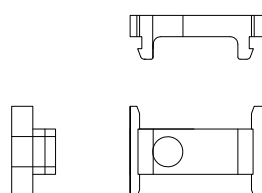
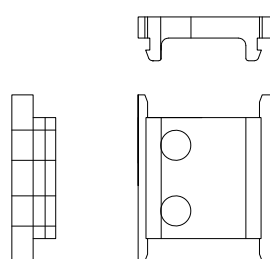
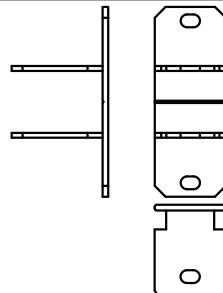
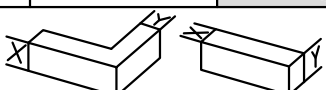
Image	Part Code	Pack	Unit	Application	Colour	
	<b>ACET332</b>  <b>Transom End Cap for French Casement</b>	<b>10</b>	<b>pack</b>	<b>ETC333</b>	MF	
					SA	
					KL	
					HP	
					M	
					GOZ	
					PC	
					W	X
					Z	X
	<b>ACET333</b>  <b>Cruciform Block</b>	<b>10</b>	<b>pack</b>	<b>ETC333</b>	MF	
					SA	
					KL	
					HP	
					M	
					GOZ	
					PC	
					W	
					Z	
	<b>ACET334</b>  <b>Transom Locator Block</b>	<b>100</b>	<b>pack</b>	<b>ETC333</b>	MF	
					SA	
					KL	
					HP	
					M	
					GOZ	
					PC	
					W	
					Z	X
	<b>ACET335</b>  <b>Transom Locator Block</b>	<b>100</b>	<b>pack</b>	<b>ETC335</b>	MF	
					SA	
					KL	
					HP	
					M	
					GOZ	
					PC	
					W	
					Z	X
	<b>ACET336</b>  <b>Cruciform Block</b>	<b>10</b>	<b>pack</b>	<b>ETC335</b>	MF	
					SA	
					KL	
					HP	
					M	
					GOZ	
					PC	
					W	
					Z	
<small>T-BARS ACVG65=2.5mm ACVG66=3.0mm ACVL150=4.0mm</small>	<small>Screw (Grub)</small>	<b>MF = Mill Finish</b> <b>GOZ = Gold</b> <b>SA = Silver Anodised</b> <b>PC = Polished Chrome</b> <b>KL = Basic Colour</b> <b>W = White</b> <b>HP = Special Colour</b> <b>Z = Black</b> <b>M = Dual Colour</b>				

Image	Part Code	Pack	Unit	Application	Colour	
	<b>ACET344</b>  <b>Corner Cleat</b>	<b>24</b>	<b>pack</b>	<b>ETC344</b>	MF	
					SA	
	<b>ACET346</b>  <b>Corner Cleat</b>	<b>24</b>	<b>pack</b>	<b>ETC346</b>	KL	
					HP	
	<b>ACET365</b>  <b>Espag. Handle Fixing Block (94mm)</b>	<b>1</b>	<b>each</b>	<b>ACET165</b> <b>ETC323</b> <b>ETC324</b> <b>ETC326</b> <b>ETC329</b> <b>ETC367</b>	M	
					GOZ	
	<b>ACET366</b>  <b>Cockspur Handle Fixing Block (94mm)</b>	<b>1</b>	<b>each</b>	<b>ACET080</b> <b>ETC323</b> <b>ETC324</b> <b>ETC326</b> <b>ETC329</b> <b>ETC367</b>	PC	
					W	
	<b>ACET367</b>  <b>Curved Espag. Handle Fixing Block (94mm)</b>	<b>1</b>	<b>each</b>	<b>ACET165</b> <b>ETC323</b> <b>ETC324</b> <b>ETC326</b> <b>ETC329</b> <b>ETC367</b>	Z	
					X	
	T-BARS ACVG65=2.5mm ACVG66=3.0mm ACVL150=4.0mm		Screw (Grub)	<b>MF = Mill Finish</b> <b>SA = Silver Anodised</b> <b>KL = Basic Colour</b> <b>HP = Special Colour</b> <b>M = Dual Colour</b>	<b>GOZ = Gold</b> <b>PC = Polished Chrome</b> <b>W = White</b> <b>Z = Black</b>	

Image	Part Code	Pack	Unit	Application	Colour	
	<b>ACET368</b>  <b>Curved Cockspur Handle Fixing Block (94mm)</b>	<b>1</b>	<b>each</b>	<b>ACET165</b> <b>ETC323</b> <b>ETC324</b> <b>ETC326</b> <b>ETC329</b> <b>ETC367</b>	MF	X
					SA	
					KL	X
					HP	X
					M	
					GOZ	
					PC	
					W	X
					Z	X
	<b>ACET380</b>  <b>Run Up Block</b>	<b>100</b>	<b>pack</b>		MF	
					SA	
					KL	
					HP	
					M	
					GOZ	
					PC	
					W	X
					Z	X
	<b>ACET385</b>  <b>Corner Keep Packers</b>	<b>20</b>	<b>pairs</b>	<b>ACET35/3</b> <b>ACET41/3</b> <b>ACET53/3</b> <b>ACET71/3</b> <b>ACET84/3</b>	MF	
					SA	
					KL	
					HP	
					M	
					GOZ	
					PC	
					W	
					Z	X
	<b>ACET393</b>  <b>Packer for ETC346</b>	<b>25</b>	<b>pack</b>	<b>ETC344</b> <b>ETC345</b> <b>ETC346</b>	MF	
					SA	
					KL	
					HP	
					M	
					GOZ	
					PC	
					W	
					Z	
	<b>ACET394</b>  <b>Keep &amp; Stay Packer</b>	<b>25</b>	<b>pack</b>	<b>ETC307</b> <b>ETC308</b> <b>ETC309</b> <b>ETC310</b> <b>ETC313</b> <b>ETC316</b> <b>ETC317</b>	MF	
					SA	
					KL	
					HP	
					M	
					GOZ	
					PC	
					W	
					Z	
		<b>MF = Mill Finish</b> <b>GOZ = Gold</b> <b>SA = Silver Anodised</b> <b>PC = Polished Chrome</b> <b>KL = Basic Colour</b> <b>W = White</b> <b>HP = Special Colour</b> <b>Z = Black</b> <b>M = Dual Colour</b>				

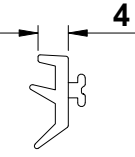

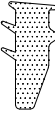
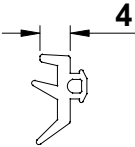
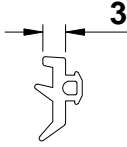
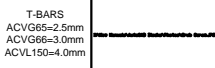

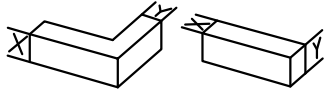
Image	Part Code	Pack	Unit	Application	Colour	
	<b>ACET835</b>  <b>Low Line External Gasket</b>	200	m	<b>ETC364</b> <b>ETC370</b> <b>ETC371</b> <b>ETC375</b>	MF	
					SA	
					KL	
					HP	
					M	
					GOZ	
					PC	
					W	
					Z	
						X
	<b>ACET836</b>  <b>Flipper Gasket</b>	250	m		MF	
					SA	
					KL	
					HP	
					M	
					GOZ	
					PC	
					W	
					Z	X
	<b>ACET840</b>  <b>5mm Low Line Internal Wedge Gasket</b>	150	m		MF	
					SA	
					KL	
					HP	
					M	
					GOZ	
					PC	
					W	
					Z	X
	<b>ACET841</b>  <b>4mm Low Line External Gasket</b>	200	m		MF	
					SA	
					KL	
					HP	
					M	
					GOZ	
					PC	
					W	
					Z	X
	<b>ACET842</b>  <b>3mm Low Line External Gasket</b>	200	m		MF	
					SA	
					KL	
					HP	
					M	
					GOZ	
					PC	
					W	
					Z	X
	T-BARS ACVG65=2.5mm ACVG66=3.0mm ACVL150=4.0mm	 Screw (Grub)	<b>MF = Mill Finish</b> <b>SA = Silver Anodised</b> <b>KL = Basic Colour</b> <b>HP = Special Colour</b> <b>M = Dual Colour</b>	<b>GOZ = Gold</b> <b>PC = Polished Chrome</b> <b>W = White</b> <b>Z = Black</b>		

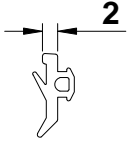


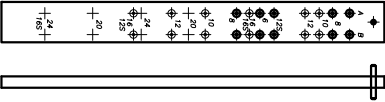
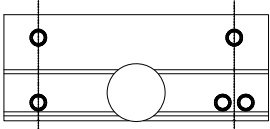

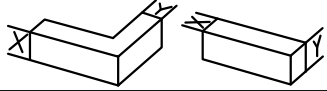
Image	Part Code	Pack	Unit	Application	Colour
	<b>ACET843</b>  <b>2mm Low Line External Gasket</b>	<b>200</b>	<b>m</b>		MF SA KL HP M GOZ PC W Z
	<b>ACET904</b>  <b>Crimping Punch</b>	<b>1</b>	<b>pair</b>	<b>ETC308</b> <b>ETC310</b> <b>ETC313</b> <b>ETC420</b>	X MF SA KL HP M GOZ PC W Z
	<b>ACET913</b>  <b>Crimping Punch</b>	<b>1</b>	<b>pair</b>	<b>ETC328</b>	MF SA KL HP M GOZ PC W Z
	<b>ACET941</b>  <b>Friction Hinge Drill Jig</b>  <b>For Standard Top &amp; Side Hung</b>	<b>1</b>	<b>each</b>	<b>ETC420</b> <b>ETC321</b> <b>ETC323</b> <b>ETC324</b> <b>ETC326</b> <b>ETC327</b> <b>ETC328</b> <b>ETC329</b>	MF SA KL HP M GOZ PC W Z
	<b>ACET945</b>  <b>Transom/Mullion Drill Jig</b>	<b>1</b>	<b>each</b>	<b>ETC333</b> <b>ETC335</b>	MF SA KL HP M GOZ PC W Z
	T-BARS ACVG65=2.5mm ACVG66=3.0mm ACVL150=4.0mm			Screw (Grub)	
<b>MF = Mill Finish</b> <b>SA = Silver Anodised</b> <b>KL = Basic Colour</b> <b>HP = Special Colour</b> <b>M = Dual Colour</b>				<b>GOZ = Gold</b> <b>PC = Polished Chrome</b> <b>W = White</b> <b>Z = Black</b>	
					

Image	Part Code	Pack	Unit	Application	Colour
	<b>ACET968</b>  <b>8.25mm Packer</b>	<b>1</b>	<b>each</b>	<b>ACET979</b> <b>ETC346</b>	MF
					SA
					KL
					HP
					M
					GOZ
					PC
					W
					Z
	<b>ACET969</b>  <b>12.8mm Packer</b>	<b>1</b>	<b>each</b>	<b>ACET979</b> <b>ETC326</b> <b>ETC329</b>	MF
					SA
					KL
					HP
					M
					GOZ
					PC
					W
					Z
	<b>ACET976</b>  <b>Vee Block</b>	<b>1</b>	<b>each</b>	<b>ACET977</b> <b>ETC307</b> <b>ETC309</b> <b>ETC316</b> <b>ETC317</b>	MF
					SA
					KL
					HP
					M
					GOZ
					PC
					W
					Z
	<b>ACET977</b>  <b>6mm Packer</b>	<b>1</b>	<b>each</b>	<b>ACET976</b> <b>ETC307</b> <b>ETC309</b> <b>ETC316</b> <b>ETC317</b>	MF
					SA
					KL
					HP
					M
					GOZ
					PC
					W
					Z
	<b>ACET978</b>  <b>Crimping Punch</b>	<b>1</b>	<b>pair</b>	<b>ETC309</b> <b>ETC315</b> <b>ETC316</b>	MF
					SA
					KL
					HP
					M
					GOZ
					PC
					W
					Z
		<b>MF = Mill Finish</b> <b>GOZ = Gold</b> <b>SA = Silver Anodised</b> <b>PC = Polished Chrome</b> <b>KL = Basic Colour</b> <b>W = White</b> <b>HP = Special Colour</b> <b>Z = Black</b> <b>M = Dual Colour</b>			

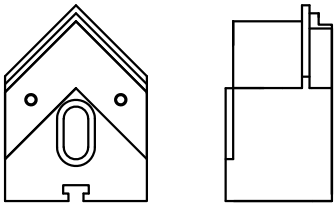
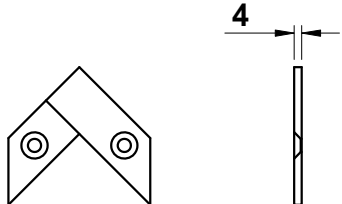
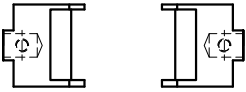
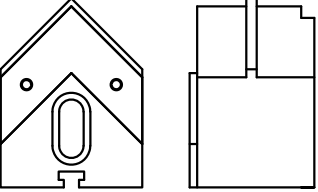
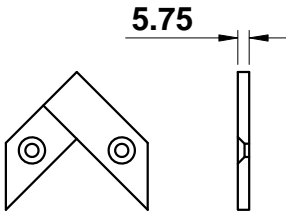


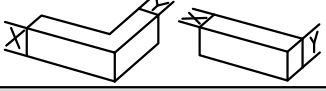
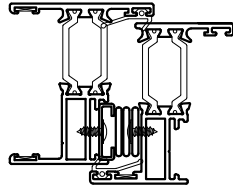
Image	Part Code	Pack	Unit	Application	Colour
	<b>ACET979</b>  <b>Vee Block</b>	<b>1</b>	<b>each</b>		MF
					SA
					KL
					HP
					M
					GOZ
					PC
					W
Z					
	<b>ACET980</b>  <b>11.8mm Packer</b>	<b>1</b>	<b>each</b>	<b>ACET979</b> <b>ETC324</b>	MF
					SA
					KL
					HP
					M
					GOZ
					PC
					W
Z					
	<b>ACET981</b>  <b>Crimping Punch</b>	<b>1</b>	<b>pair</b>	<b>ETC321</b> <b>ETC323</b> <b>ETC324</b> <b>ETC326</b> <b>ETC327</b> <b>ETC329</b> <b>ETC344</b> <b>ETC345</b> <b>ETC346</b>	MF
					SA
					KL
					HP
					M
					GOZ
					PC
					W
Z					
	<b>ACET982</b>  <b>Vee Block</b>	<b>1</b>	<b>each</b>	<b>ACET983</b> <b>ETC310</b> <b>ETC313</b> <b>ETC328</b> <b>ETC420</b>	MF
					SA
					KL
					HP
					M
					GOZ
					PC
					W
Z					
	<b>ACET983</b>  <b>5.75mm Packer</b>	<b>1</b>	<b>each</b>	<b>ACET979</b> <b>ACET982</b> <b>ETC310</b> <b>ETC313</b> <b>ETC328</b> <b>ETC344</b> <b>ETC345</b> <b>ETC420</b>	MF
					SA
					KL
					HP
					M
					GOZ
					PC
					W
Z					
	T-BARS ACVG65=2.5mm ACVG66=3.0mm ACVL150=4.0mm		<b>MF = Mill Finish</b> <b>GOZ = Gold</b> <b>SA = Silver Anodised</b> <b>PC = Polished Chrome</b> <b>KL = Basic Colour</b> <b>W = White</b> <b>HP = Special Colour</b> <b>Z = Black</b> <b>M = Dual Colour</b>		



Image	Part Code	Pack	Unit	Application	Colour	
	<b>ACET990</b> <b>9.3mm Packer</b>	<b>1</b>	<b>each</b>	<b>ACET979</b> <b>ACET982</b> <b>ETC308</b> <b>ETC344</b> <b>ETC345</b>	MF	
					SA	
					KL	
					HP	
					M	
					GOZ	
					PC	
					W	
					Z	
	<b>ACET991</b> <b>7.7mm Packer</b>	<b>1</b>	<b>each</b>	<b>ACET979</b> <b>ETC323</b>	MF	
					SA	
					KL	
					HP	
					M	
					GOZ	
					PC	
					W	
					Z	
	<b>ACVG49</b> <b>Wedge Gasket</b>	<b>100</b>	<b>m</b>	<b>ETC314</b>	MF	
					SA	
					KL	
					HP	
					M	
					GOZ	
					PC	
					W	
					Z	
	<b>ACVL059</b> <b>End Caps</b>	<b>1</b>	<b>pair</b>	<b>VL72</b>	MF	
					SA	
					KL	
					HP	
					M	
					GOZ	
					PC	
					W	X
					Z	X
	<b>ACVL061</b> <b>Rivet</b>	<b>100</b>	<b>pack</b>	<b>VL72</b>	MF	
					SA	
					KL	
					HP	
					M	
					GOZ	
					PC	
					W	
					Z	
<small>T-BARS</small> <small>ACVG65=2.5mm</small> <small>ACVG66=3.0mm</small> <small>ACVL150=4.0mm</small>	<small>Screw (Grub)</small>	<b>MF = Mill Finish</b> <b>SA = Silver Anodised</b> <b>KL = Basic Colour</b> <b>HP = Special Colour</b> <b>M = Dual Colour</b>	<b>GOZ = Gold</b> <b>PC = Polished Chrome</b> <b>W = White</b> <b>Z = Black</b>			

Image	Part Code	Pack	Unit	Application	Colour
	<b>ACW20024</b>  <b>Stainless Steel Chevron</b>	100	pack		MF SA KL HP M GOZ PC W Z
	<b>ACW20034</b>  <b>4mm Low Line Internal Wedge Gasket</b>	200	m		MF SA KL HP M GOZ PC W Z X
	<b>WCA106</b>  <b>Stainless Steel Chevron</b>	50	pack	<b>ETC315</b>	MF SA KL HP M GOZ PC W Z
	<b>HEJ050ALZ</b>  <b>Drill jig for ACET040</b>	1	each	<b>ETC157</b> <b>ETC158</b> <b>ETC178</b> <b>ETC179</b>	MF SA KL HP M GOZ PC W Z
	<b>WUT024HSZA</b>  <b>Manual Crimper</b>  <b>Note: Vee blocks &amp; punches are sold separately.</b> <b>Please see Page E04.</b>	1	each		MF SA KL HP M GOZ PC W Z
	T-BARS ACVG65=2.5mm ACVG66=3.0mm ACVL150=4.0mm			Screw (Grub)	MF = Mill Finish SA = Silver Anodised KL = Basic Colour HP = Special Colour M = Dual Colour GOZ = Gold PC = Polished Chrome W = White Z = Black



### Friction Hinge Stays 13mm Stack (Standard)

#### Top Hung Windows

Top Hung	Type of Hinge / Stay	Max. Vent	Height		Typical Width
		Weight (kgs)	Mimimum	Maximum	
ACINDS10	Standard	16	275	400	-
ACINDS16		21	400	780	-
ACINDS20		20	700	1100	-
ACINDS24		40	850	1300	-
ACINDA10	Austenitic	16	275	400	-
ACINDA16		21	400	780	-
ACINDA20		20	700	1100	-
ACINDA24		40	850	1300	-
ACINV10	Vector	16	275	400	-
ACINV16		21	400	780	-
ACINV20		26	700	1100	-
ACINV24		40	850	1300	-
ACINDR12	Restricted	20	350	550	-
ACINDR16		21	500	780	-
ACINDR20		26	700	1100	-
ACINDR24		40	850	1300	-

#### Side Hung Windows

Side Hung	Type of Hinge / Stay	Max. Vent	Width		Typical Height
		Weight (kgs)	Minimum	Maximum	
ACINDSSH12	Standard	22	300	600	-
ACINDSSH16		28	400	700	-
ACINDASH12	Austenitic	22	300	600	-
ACINDASH16		28	400	700	-
ACINVSH12*	Vector	22	300	600	-
ACINVSH16		24	400	700	-
ACINDRSH12	Restricted	22	300	600	-
ACINDRSH16		24	400	700	-
ACINDESH12	Egress	22	300	600	-
ACINDESH16		24	400	700	-

Note1: Vent Height / Width is measured in mm.

Note2: Top hung height and side hung width sizes to be reduced by 2mm where size is 450mm or smaller

Note3: Typical Dimensions based on Max. Size and Glass 30kg/metre

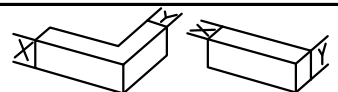
Note4: \* ACINVSH12 has a minimum order of 25 pairs

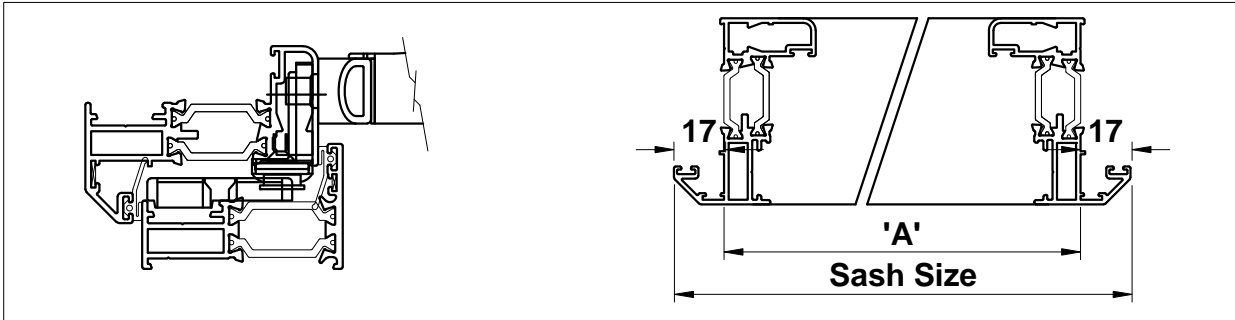
T-BARS  
ACVG65=2.5mm  
ACVG66=3.0mm  
ACVL150=4.0mm

Screw (Grub)

MF = Mill Finish  
SA = Silver Anodised  
KL = Basic Colour  
HP = Special Colour  
M = Dual Colour

GOZ = Gold  
PC = Polished Chrome  
W = White  
Z = Black

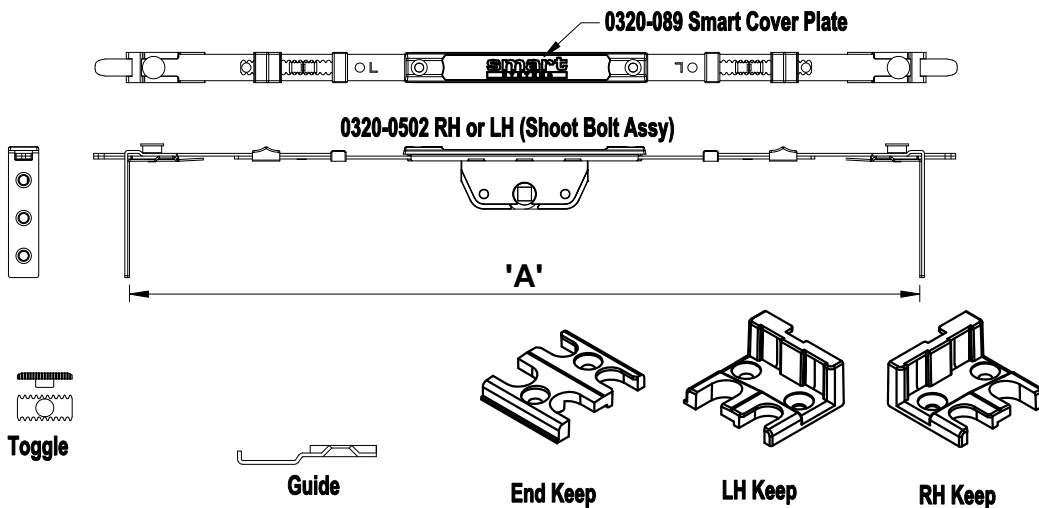




Part Code	Sash Rebate Size ('A')		Handing
	Minimum	Maximum	
ACET35R/3	350	410	Right Handle
ACET35L/3	350	410	Left Handle
ACET41R/3	410	530	Right Handle
ACET41L/3	410	530	Left Handle
ACET53R/3	530	710	Right Handle
ACET53L/3	530	710	Left Handle
ACET71R/3	710	945	Right Handle
ACET71L/3	710	945	Left Handle
ACET84R/3	945	1400	Right Handle
ACET84L/3	945	1400	Left Handle

**Note1:** Sash Limitations are Side Hung Height or Top Hung Width

**Note2:** To Suit Handle ACET165



T-BARS ACVG65=2.5mm ACVG66=3.0mm ACVL150=4.0mm	Screw (Grub)
---	--------------

**ACET450**  
**450mm Extension Rods**

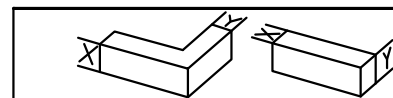









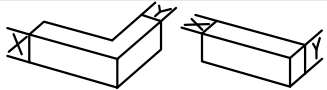
Image	Part Code	Pack	Unit	Application	Colour
	<b>ACMX09700</b> <b>Alu. Polish</b>	<b>1</b>	<b>each</b>		MF SA KL HP M GOZ W Z
	<b>ACMX09761</b> <b>Maxi Gloss</b>	<b>1</b>	<b>each</b>		MF SA KL HP M GOZ W Z
	<b>ACMX09762</b> <b>Alu. Bright</b>	<b>1</b>	<b>each</b>		MF SA KL HP M GOZ W Z
	<b>ACMX09763</b> <b>Teflon Spray</b>	<b>1</b>	<b>each</b>		MF SA KL HP M GOZ W Z
	<b>ACMX09764</b> <b>Maxi Clean</b>	<b>1</b>	<b>each</b>		MF SA KL HP M GOZ W Z
 T-BARS ACVG65=2.5mm ACVG66=3.0mm ACVL150=4.0mm	 Screw (Grub)	<b>MF = Mill Finish</b> <b>SA = Silver Anodised</b> <b>KL = Basic Colour</b> <b>HP = Special Colour</b>		<b>M = Dual Colour</b> <b>GOZ = Gold</b> <b>W = White</b> <b>Z = Black</b>	

Image	Part Code	Pack	Unit	Application	Colour
	<b>ACMX09765</b>  <b>Alu. Cleaner</b>	<b>1</b>	<b>each</b>		MF
					SA
					KL
					HP
					M
					GOZ
					W
					Z
	<b>ACMX09770</b>  <b>Roll &amp; Wrap 100mm</b>	<b>1</b>	<b>each</b>		MF
					SA
					KL
					HP
					M
					GOZ
					W
					Z
	<b>ACMX09775</b>  <b>Grip Handwrap</b>	<b>1</b>	<b>each</b>		MF
					SA
					KL
					HP
					M
					GOZ
					W
					Z
	<b>ACMX09801</b>  <b>Protective Tape 50mm</b>	<b>1</b>	<b>each</b>		MF
					SA
					KL
					HP
					M
					GOZ
					W
					Z
	<b>ACMX09802</b>  <b>Protective Tape 70mm</b>	<b>1</b>	<b>each</b>		MF
					SA
					KL
					HP
					M
					GOZ
					W
					Z
 <small>T-BARS ACVG65=2.5mm ACVG66=3.0mm ACVL150=4.0mm</small>	 <small>Screw (Grub)</small>	<b>MF = Mill Finish</b> <b>M = Dual Colour</b> <b>SA = Silver Anodised</b> <b>GOZ = Gold</b> <b>KL = Basic Colour</b> <b>W = White</b> <b>HP = Special Colour</b> <b>Z = Black</b>		 	

Image	Part Code	Pack	Unit	Application	Colour																
	<b>ACMX09830</b> <b>Rubber Sealant</b>	<b>1</b>	<b>each</b>		<table border="1"> <tr><td>MF</td><td></td></tr> <tr><td>SA</td><td></td></tr> <tr><td>KL</td><td></td></tr> <tr><td>HP</td><td></td></tr> <tr><td>M</td><td></td></tr> <tr><td>GOZ</td><td></td></tr> <tr><td>W</td><td></td></tr> <tr><td>Z</td><td></td></tr> </table>	MF		SA		KL		HP		M		GOZ		W		Z	
MF																					
SA																					
KL																					
HP																					
M																					
GOZ																					
W																					
Z																					
	<b>ACSIL04</b> <b>Sealing Glue</b>	<b>1</b>	<b>each</b>		<table border="1"> <tr><td>MF</td><td></td></tr> <tr><td>SA</td><td></td></tr> <tr><td>KL</td><td></td></tr> <tr><td>HP</td><td></td></tr> <tr><td>M</td><td></td></tr> <tr><td>GOZ</td><td></td></tr> <tr><td>W</td><td><b>X</b></td></tr> <tr><td>Z</td><td><b>X</b></td></tr> </table>	MF		SA		KL		HP		M		GOZ		W	<b>X</b>	Z	<b>X</b>
MF																					
SA																					
KL																					
HP																					
M																					
GOZ																					
W	<b>X</b>																				
Z	<b>X</b>																				
	<b>ACSIL08</b> <b>Silicon Gun</b>	<b>1</b>	<b>each</b>		<table border="1"> <tr><td>MF</td><td></td></tr> <tr><td>SA</td><td></td></tr> <tr><td>KL</td><td></td></tr> <tr><td>HP</td><td></td></tr> <tr><td>M</td><td></td></tr> <tr><td>GOZ</td><td></td></tr> <tr><td>W</td><td></td></tr> <tr><td>Z</td><td></td></tr> </table>	MF		SA		KL		HP		M		GOZ		W		Z	
MF																					
SA																					
KL																					
HP																					
M																					
GOZ																					
W																					
Z																					
	<b>ACSIL013</b> <b>Glue for Mitre</b>	<b>1</b>	<b>each</b>		<table border="1"> <tr><td>MF</td><td></td></tr> <tr><td>SA</td><td></td></tr> <tr><td>KL</td><td></td></tr> <tr><td>HP</td><td></td></tr> <tr><td>M</td><td></td></tr> <tr><td>GOZ</td><td></td></tr> <tr><td>W</td><td></td></tr> <tr><td>Z</td><td></td></tr> </table>	MF		SA		KL		HP		M		GOZ		W		Z	
MF																					
SA																					
KL																					
HP																					
M																					
GOZ																					
W																					
Z																					
	<b>ACSIL014</b> <b>Anti Corrosive Clear Lacquer</b>	<b>1</b>	<b>each</b>		<table border="1"> <tr><td>MF</td><td></td></tr> <tr><td>SA</td><td></td></tr> <tr><td>KL</td><td></td></tr> <tr><td>HP</td><td></td></tr> <tr><td>M</td><td></td></tr> <tr><td>GOZ</td><td></td></tr> <tr><td>W</td><td></td></tr> <tr><td>Z</td><td></td></tr> </table>	MF		SA		KL		HP		M		GOZ		W		Z	
MF																					
SA																					
KL																					
HP																					
M																					
GOZ																					
W																					
Z																					
 <p>T-BARS ACVG65=2.5mm ACVG66=3.0mm ACVL150=4.0mm</p>  <p>Screw (Grub)</p>	<p><b>MF = Mill Finish</b> <b>SA = Silver Anodised</b> <b>KL = Basic Colour</b> <b>HP = Special Colour</b></p> <p><b>M = Dual Colour</b> <b>GOZ = Gold</b> <b>W = White</b> <b>Z = Black</b></p>																				

Image	Part Code	Pack	Unit	Application	Colour
	<b>ACMX09830</b> <b>Rubber Sealant</b>	<b>1</b>	<b>each</b>		MF SA KL HP M GOZ W Z
	<b>ACSIL04</b> <b>Sealing Glue</b>	<b>1</b>	<b>each</b>		MF SA KL HP M GOZ W <b>X</b> Z <b>X</b>
	<b>ACSIL08</b> <b>Silicon Gun</b>	<b>1</b>	<b>each</b>		MF SA KL HP M GOZ W Z
	<b>ACSIL013</b> <b>Glue for Mitre</b>	<b>1</b>	<b>each</b>		MF SA KL HP M GOZ W Z
	<b>ACSIL014</b> <b>Anti Corrosive Clear Lacquer</b>	<b>1</b>	<b>each</b>		MF SA KL HP M GOZ W Z
	<p>T-BARS ACV665=2.5mm ACV666=3.0mm ACVL150=4.0mm</p> <p>Screw (Grub)</p>				<p><b>MF = Mill Finish</b> <b>SA = Silver Anodised</b> <b>KL = Basic Colour</b> <b>HP = Special Colour</b></p> <p><b>M = Dual Colour</b> <b>GOZ = Gold</b> <b>W = White</b> <b>Z = Black</b></p>
					

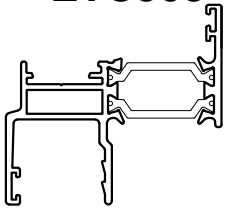


Section C

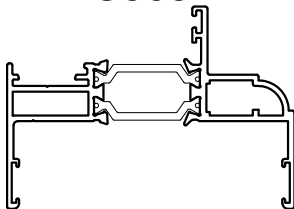
Section C  
Standard Stays Only

Outerframe

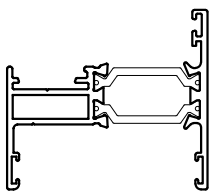
**ETC308**



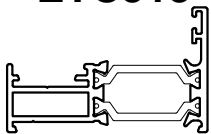
**ETC309**



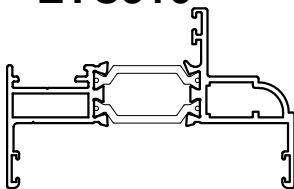
**ETC310**



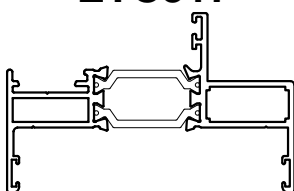
**ETC313**



**ETC316**

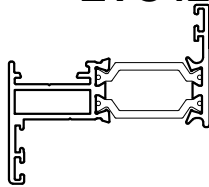


**ETC317**

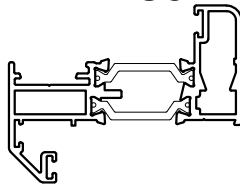


Vent

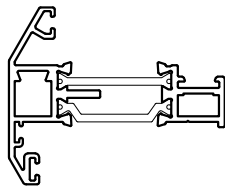
**ETC420**



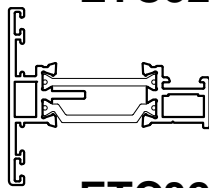
**ETC321**



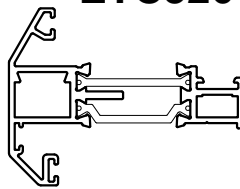
**ETC323**



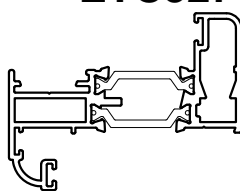
**ETC324**



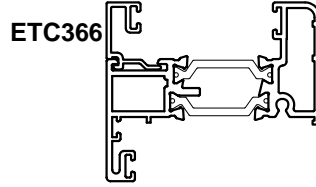
**ETC326**



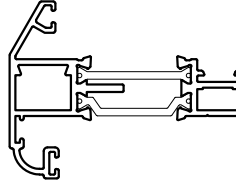
**ETC327**



**ETC328**

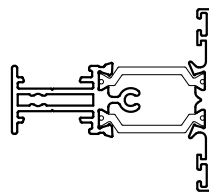


**ETC329**

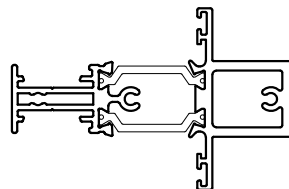


Transom/Mullion

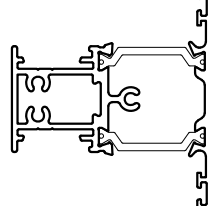
**ETC333**



**ETC334**

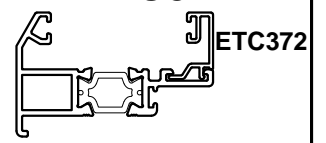


**ETC335**

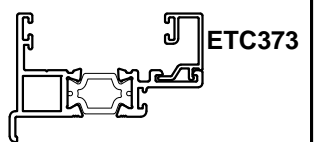


Reverse Adaptor

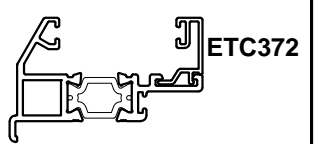
**ETC344**



**ETC345**



**ETC346**



Bead

ETC375



ETC371



ETC364



ETC370



ETC367



ETC273

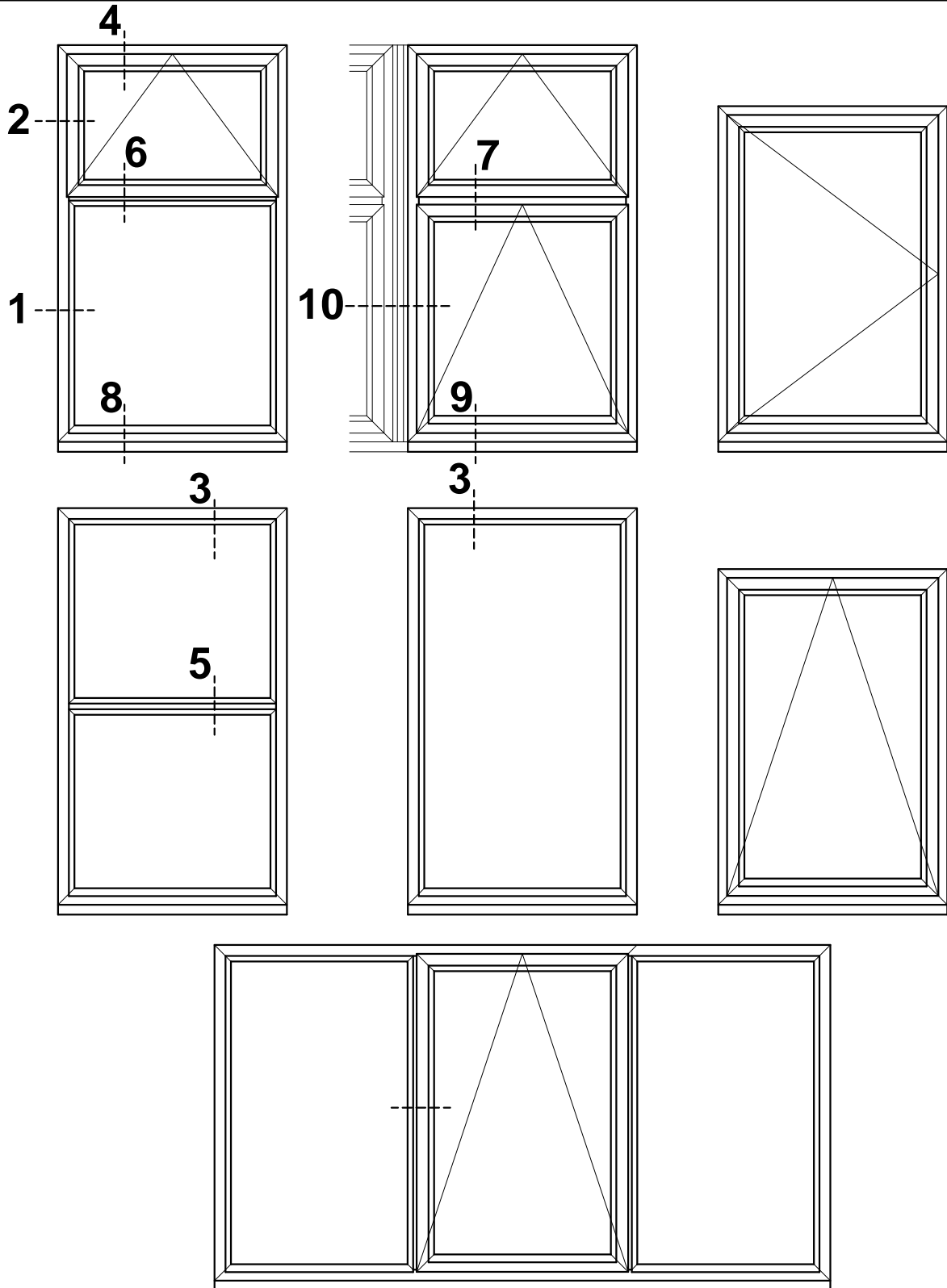


ETC374



Scale 1:2

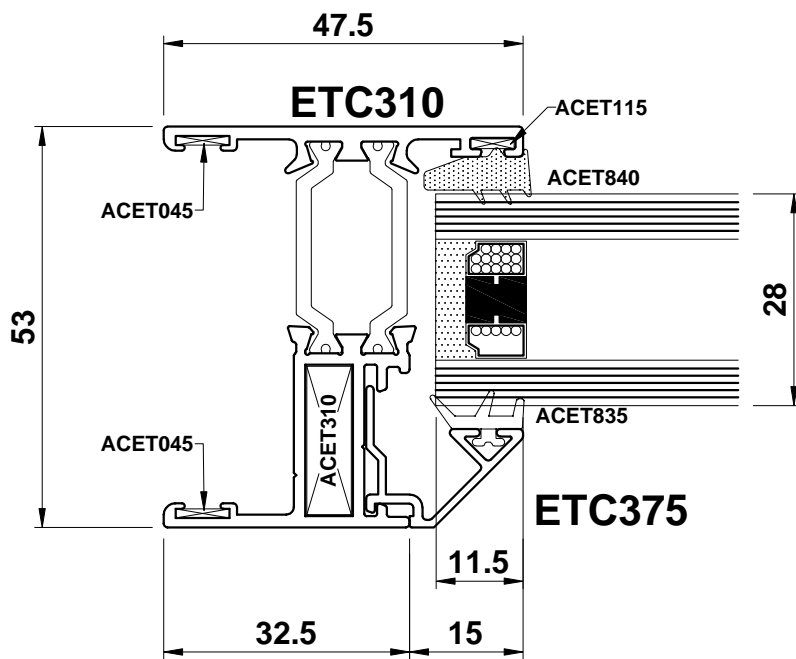
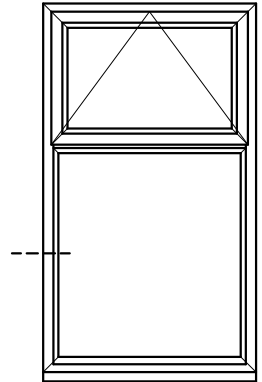
**Standard Stays**



**Do Not Scale From This Drawing**

**Standard Stays**

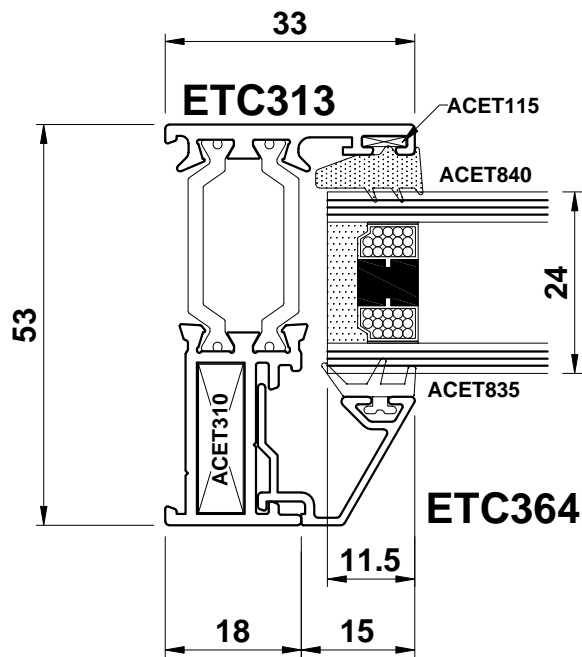
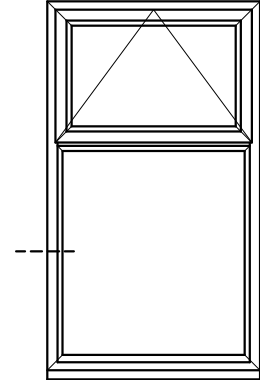
**Detail 1A**



**Do Not Scale From This Drawing**

**Standard Stays**

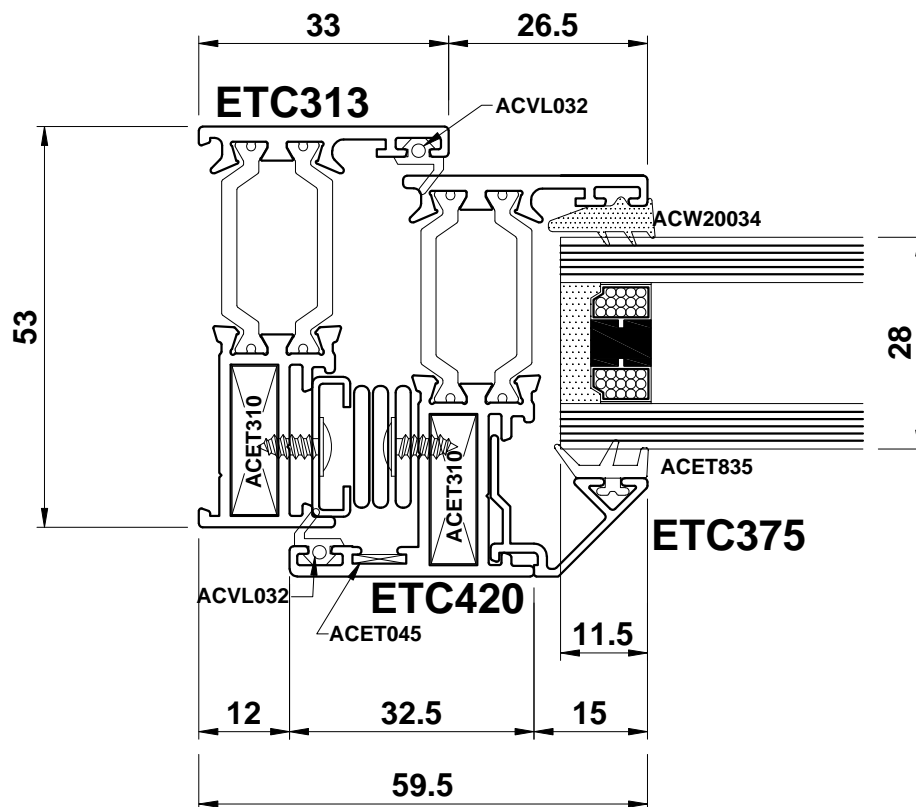
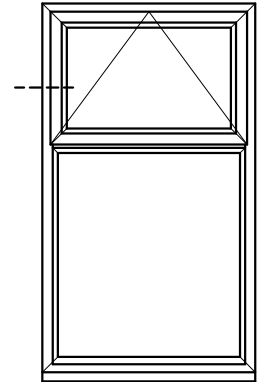
**Detail 1B**



**Do Not Scale From This Drawing**

**Standard Stays**

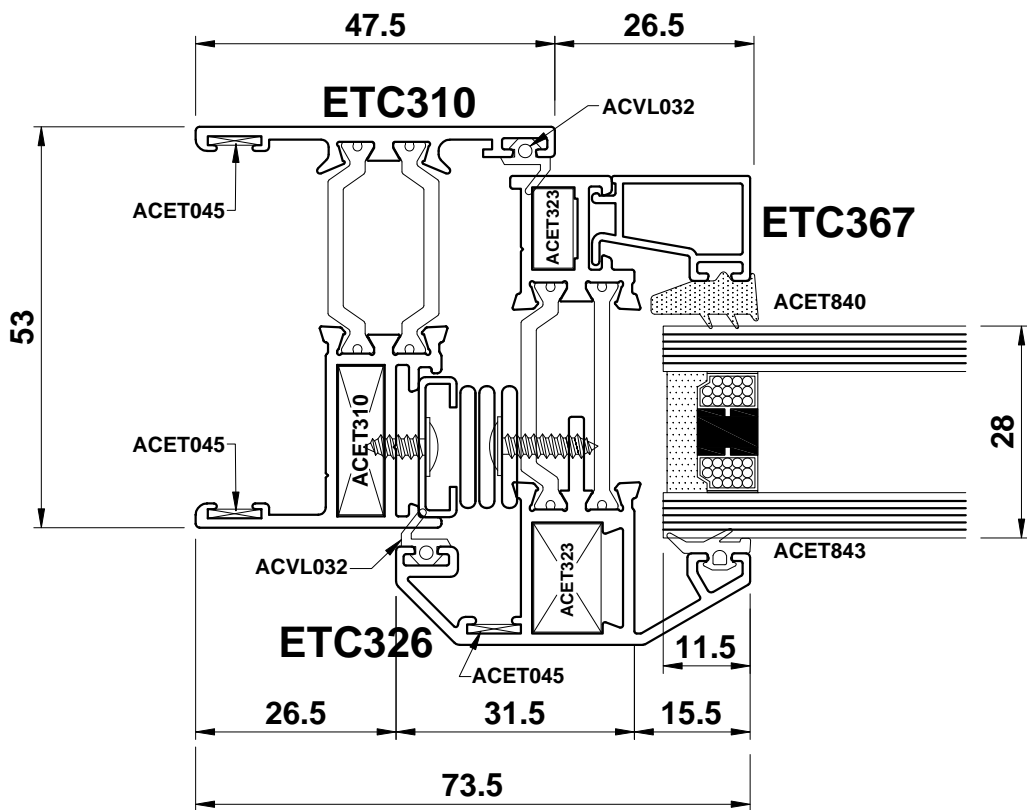
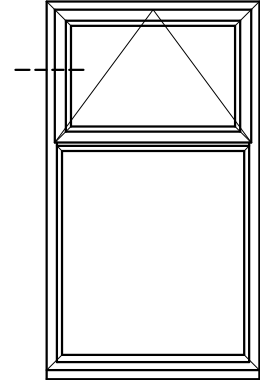
**Detail 2A**



**Do Not Scale From This Drawing**

**Standard Stays**

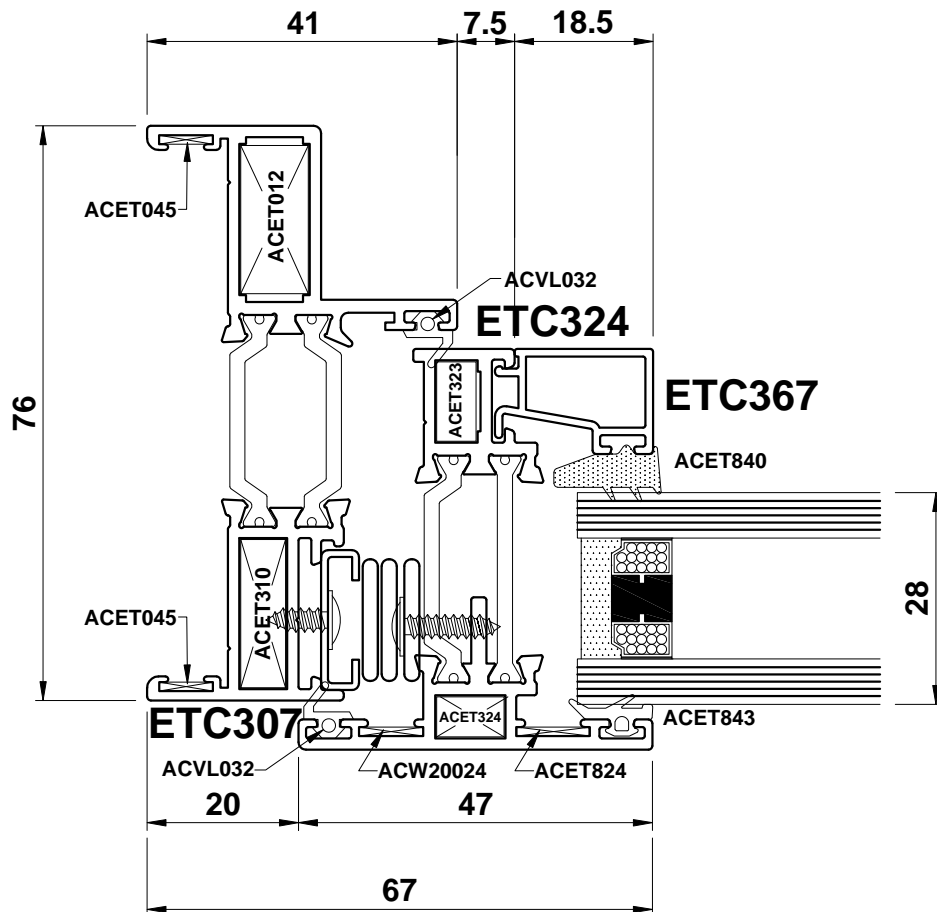
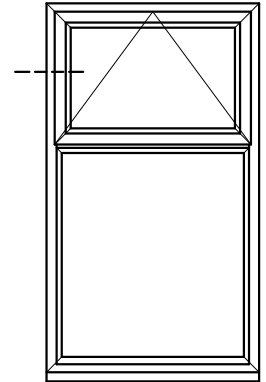
**Detail 2B**



**Do Not Scale From This Drawing**

**Standard Stays**

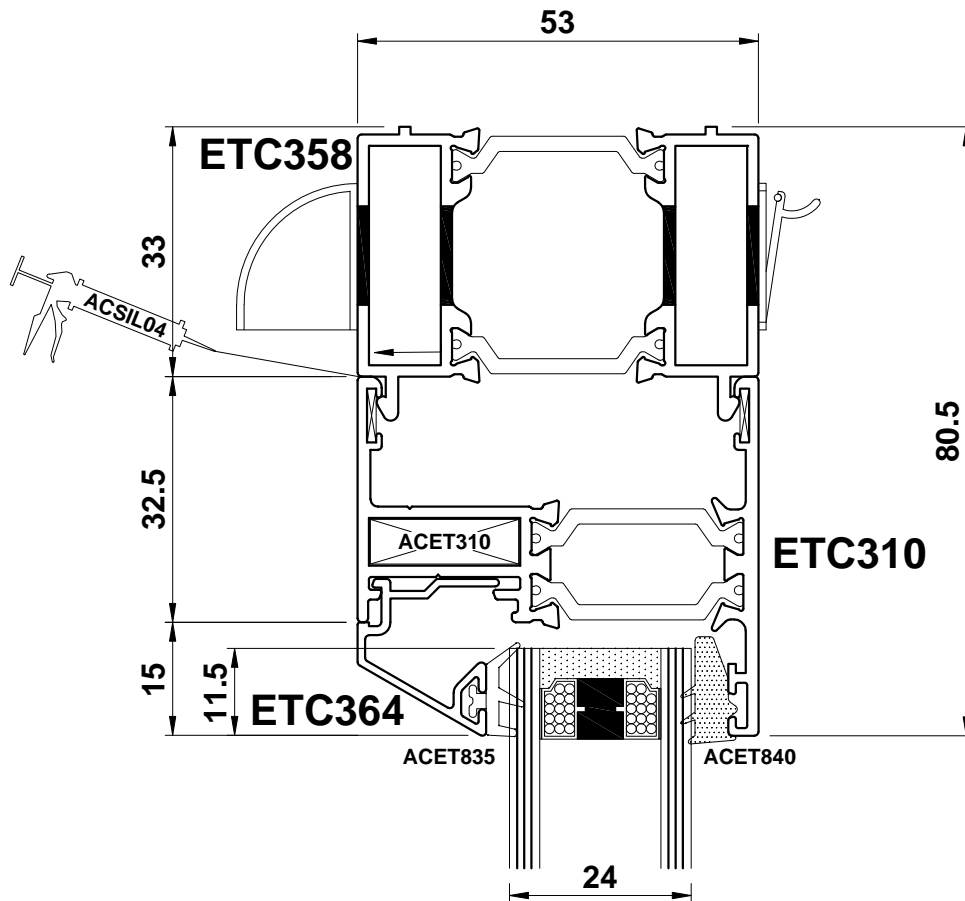
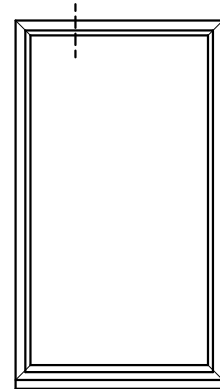
**Detail 2C**



**Do Not Scale From This Drawing**

**Standard Stays**

**Detail 3A**

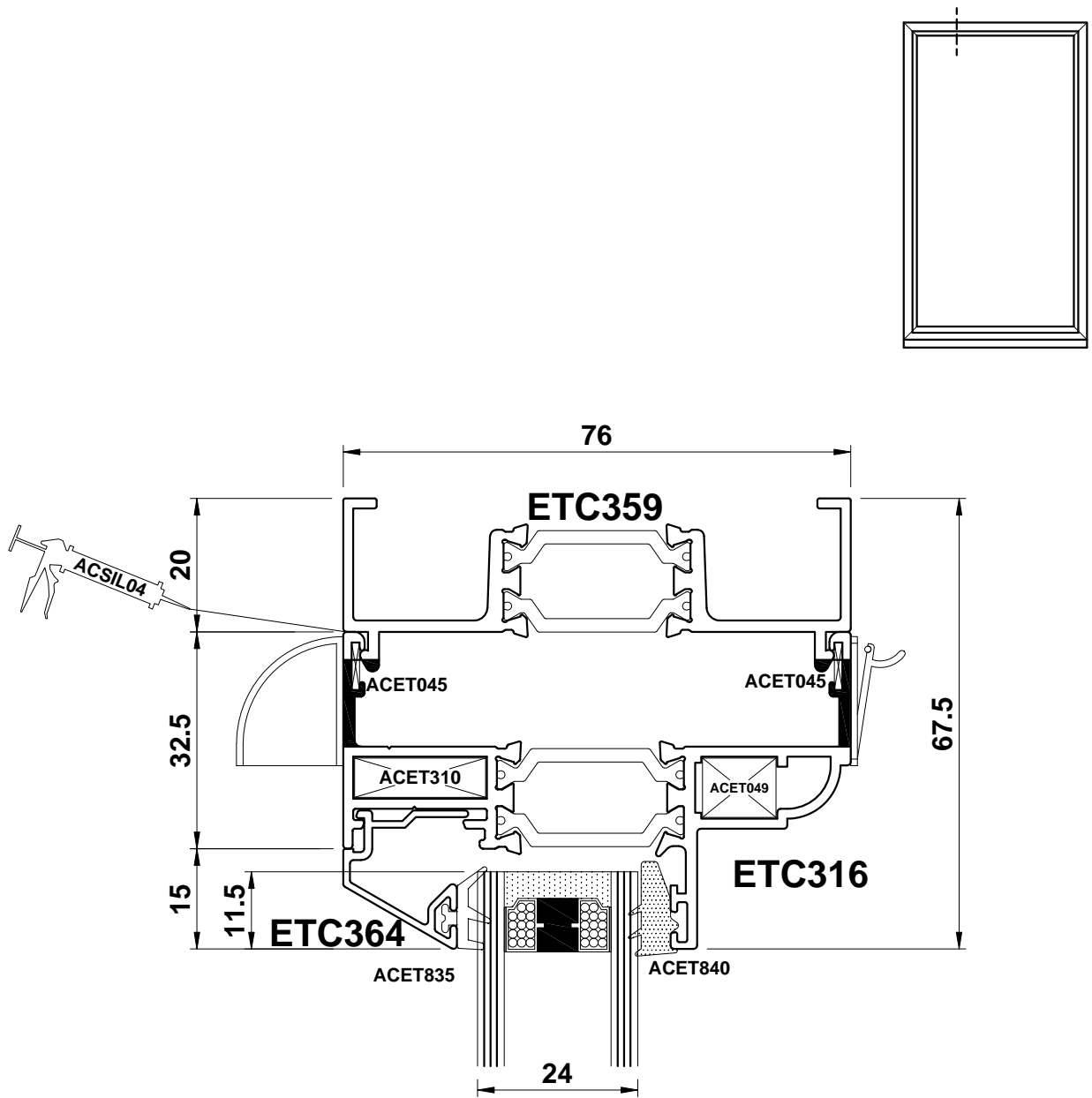


**Do Not Scale From This Drawing**



**Standard Stays**

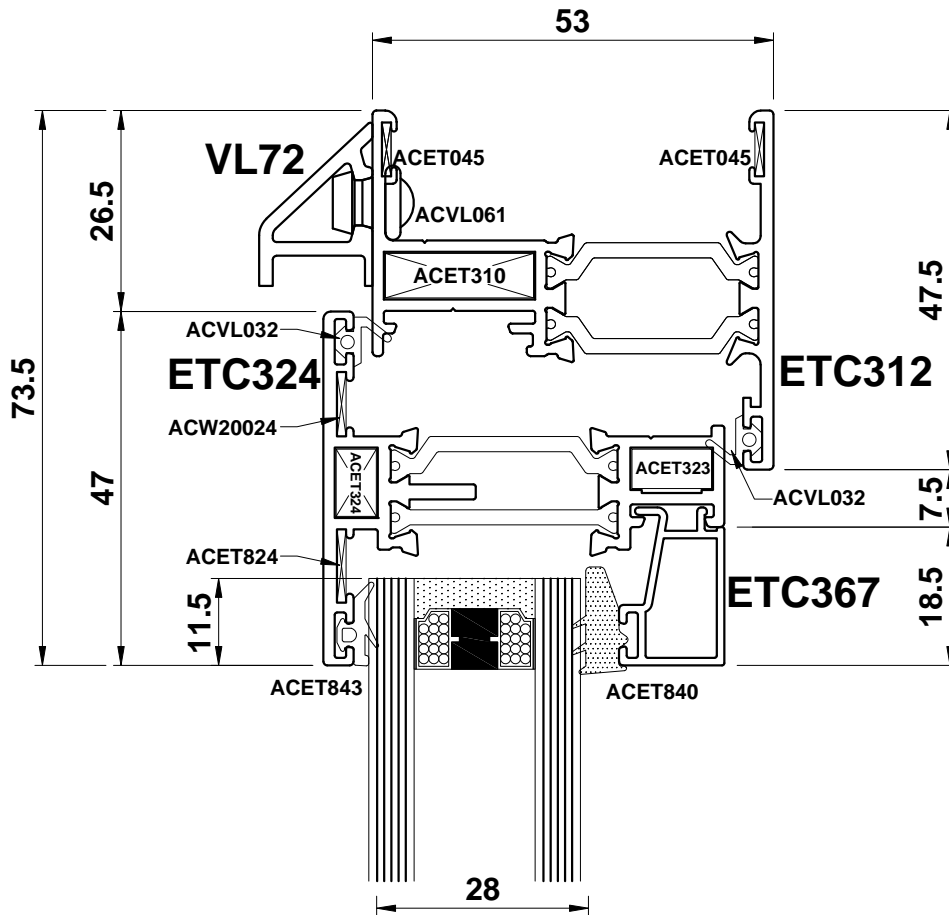
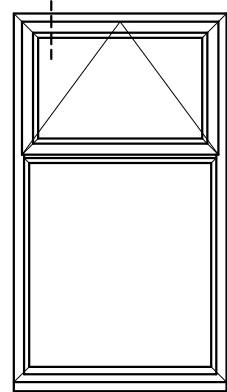
**Detail 3B**



**Do Not Scale From This Drawing**

**Standard Stays**

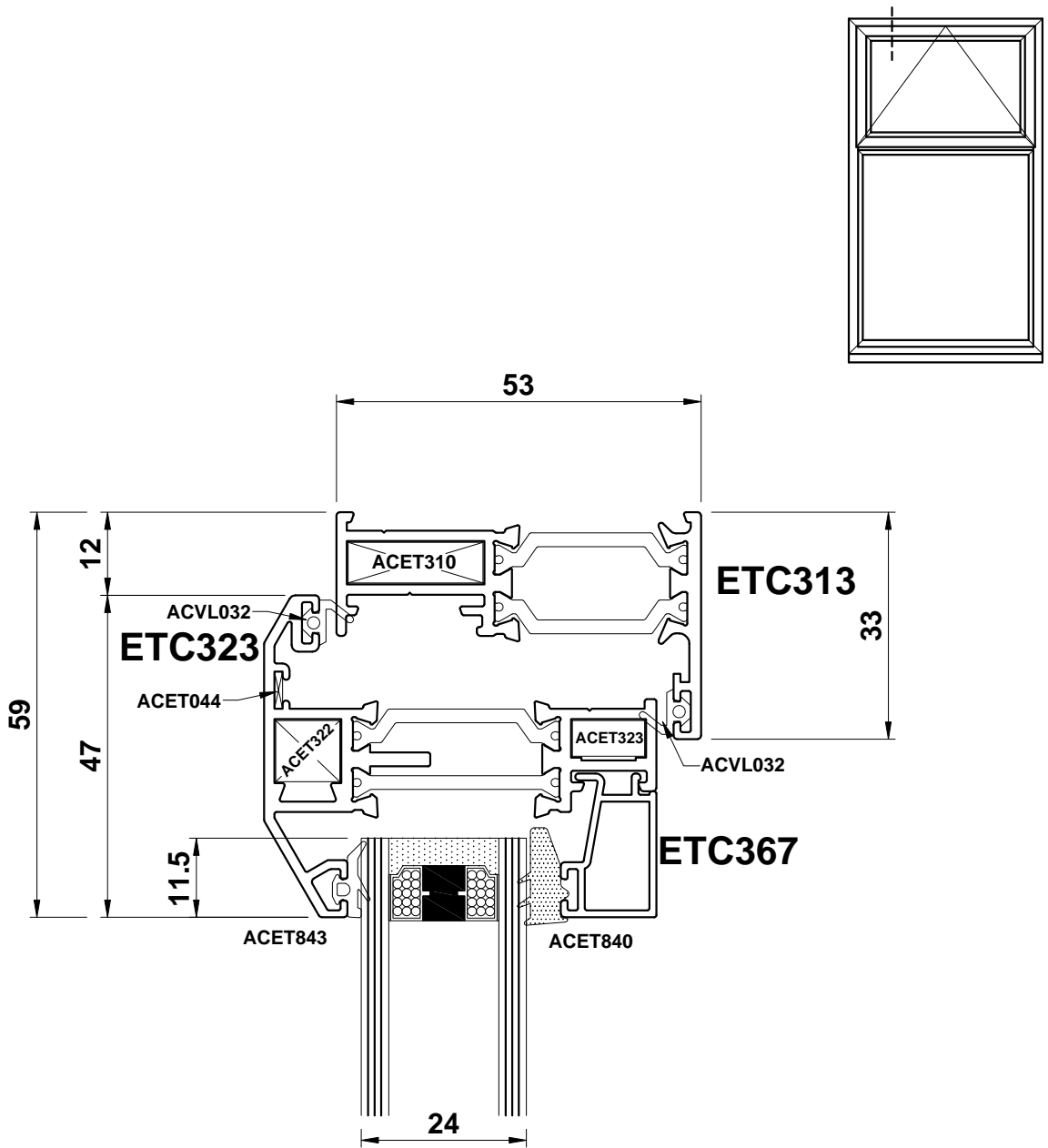
**Detail 4A**



**Do Not Scale From This Drawing**

**Standard Stays**

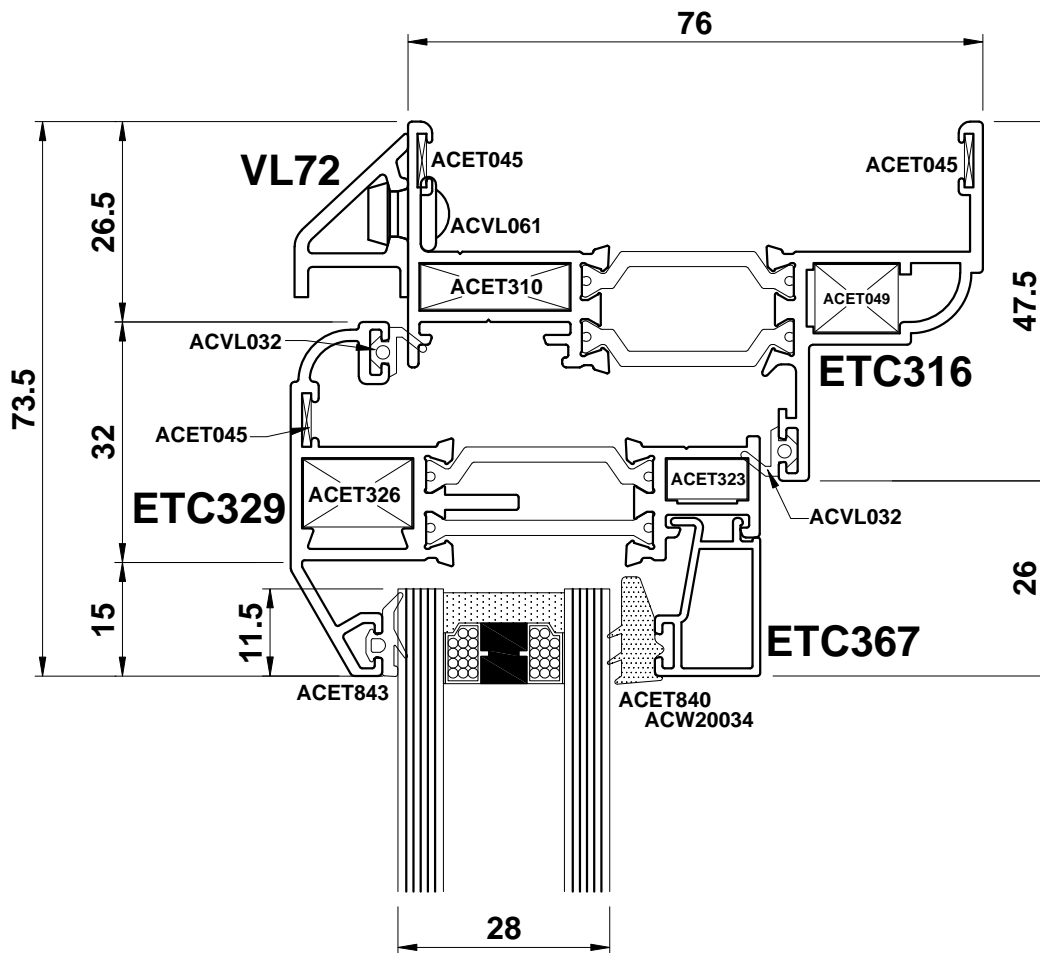
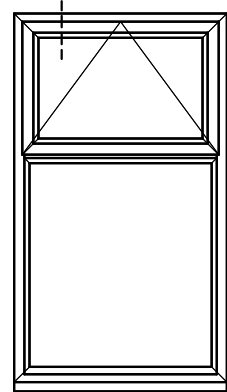
**Detail 4B**



**Do Not Scale From This Drawing**

**Standard Stays**

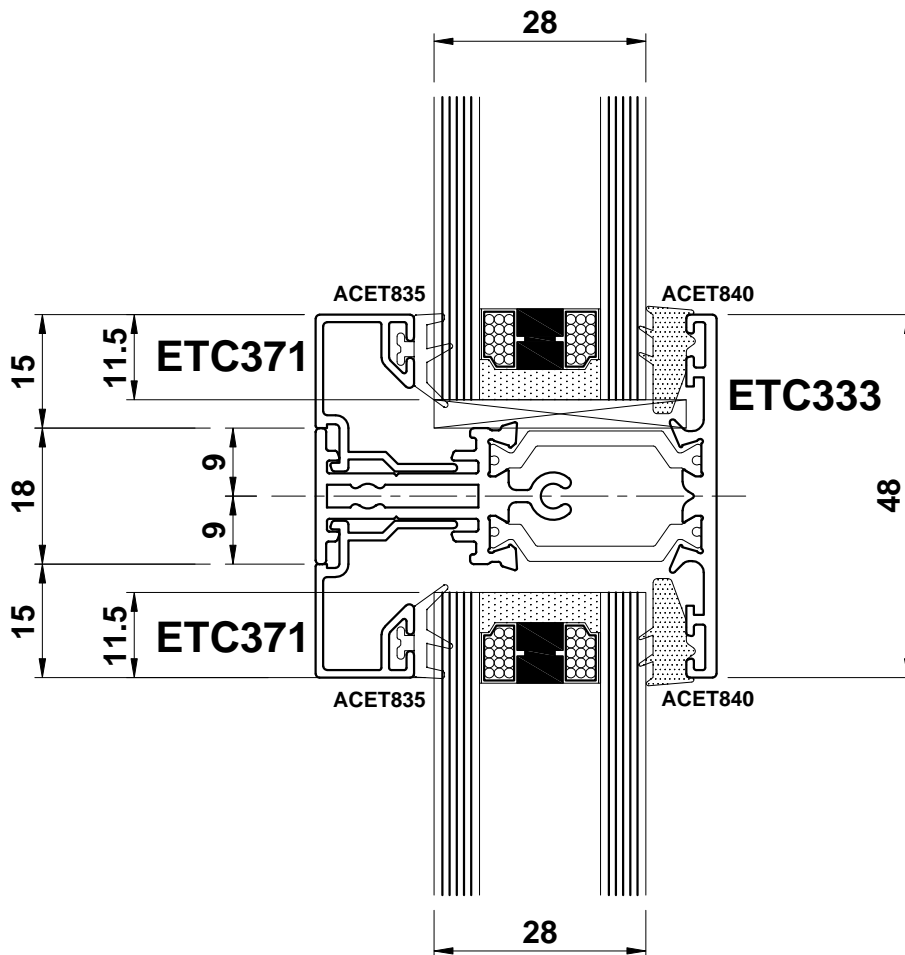
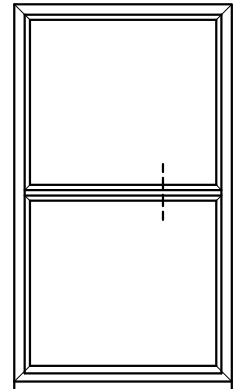
**Detail 4C**



**Do Not Scale From This Drawing**

**Standard Stays**

**Detail 5A**

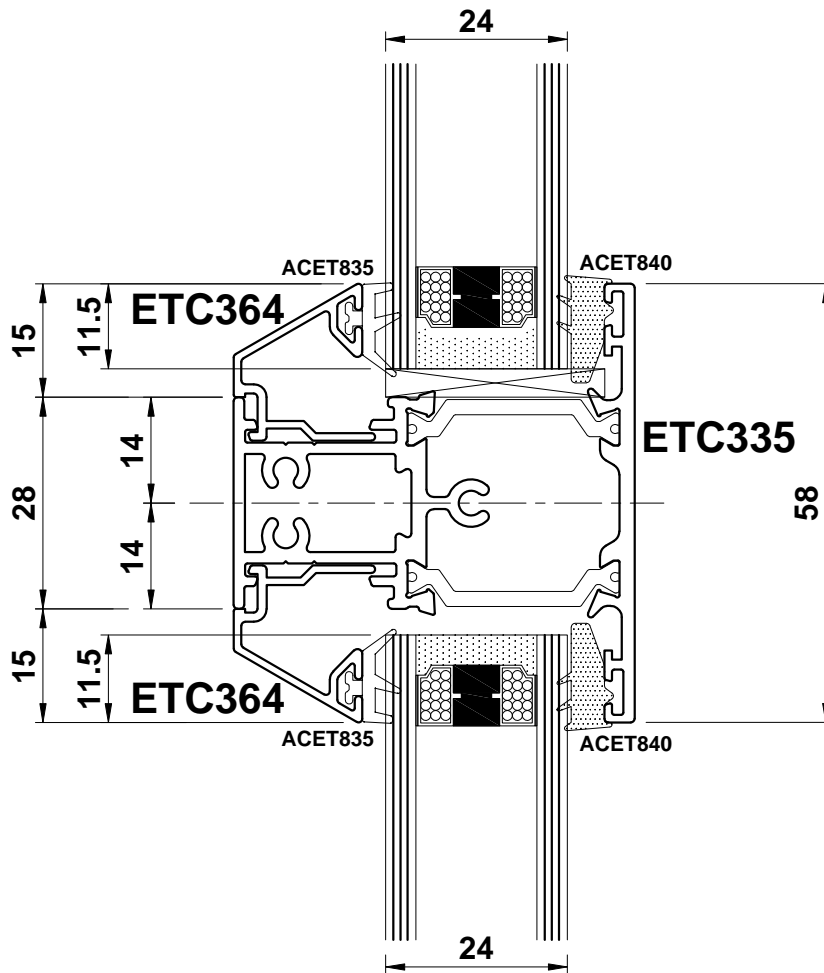
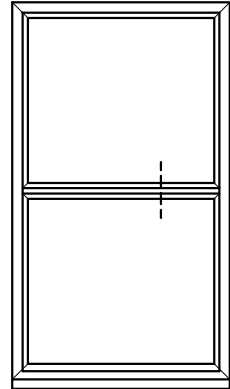


**Note:** Transoms will drain through the join to the outerframe.

**Do Not Scale From This Drawing**

**Standard Stays**

**Detail 5B**

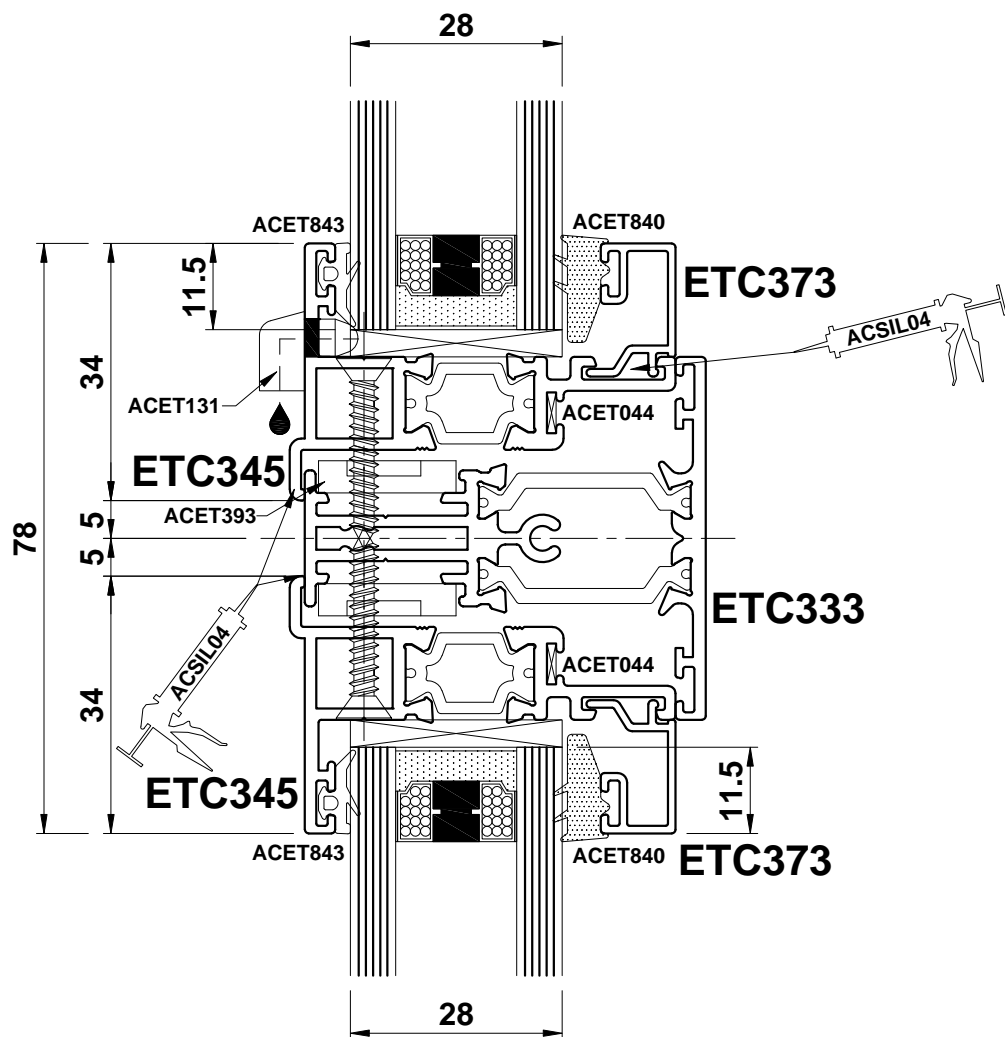
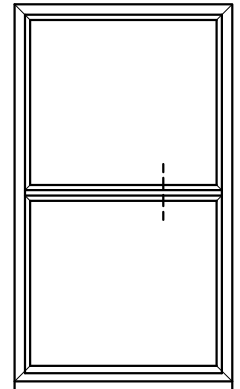


**Note:** Transoms will drain through the joint to the outerframe.

**Do Not Scale From This Drawing**

**Standard Stays**

**Detail 5C**

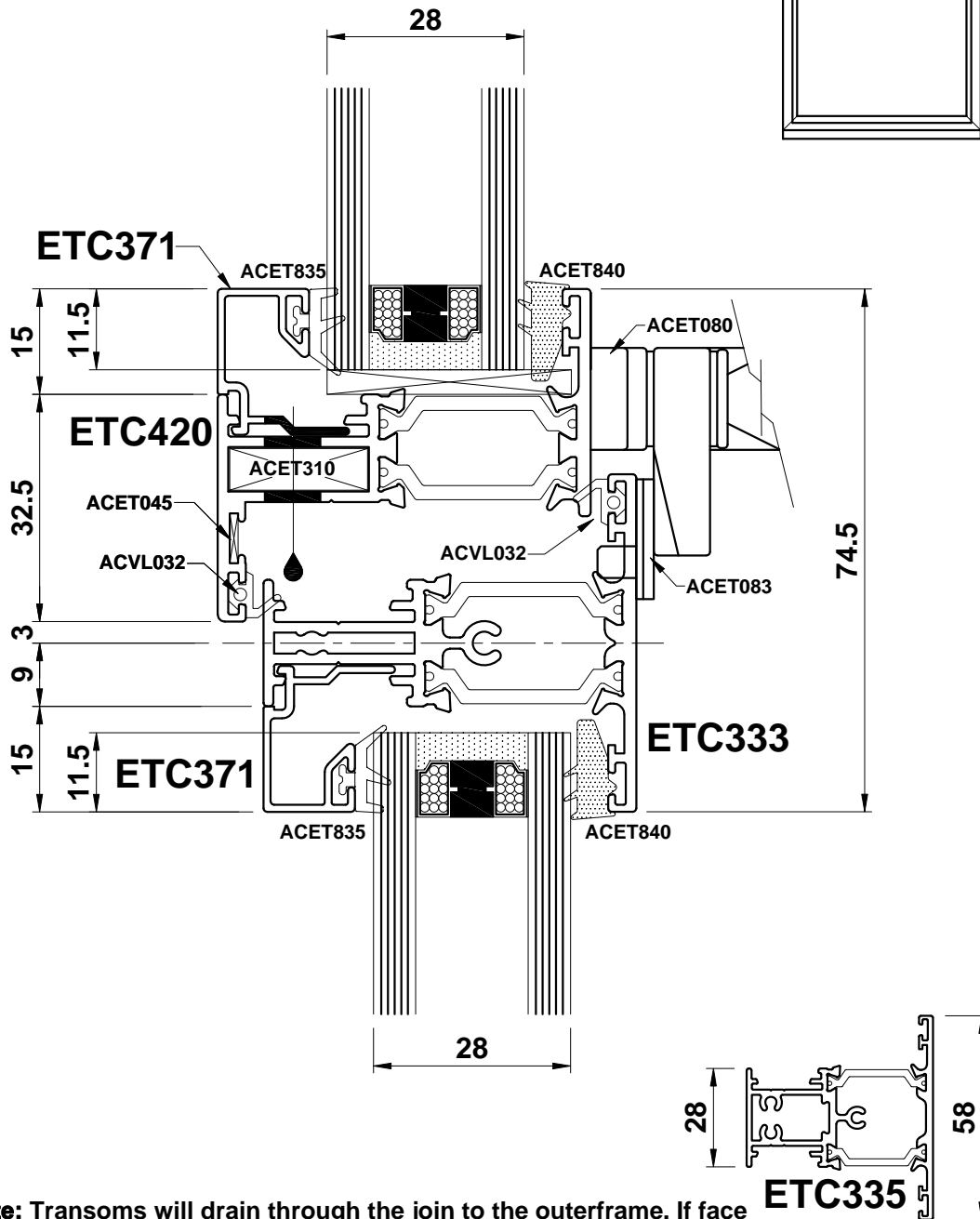


**Note:** Transoms will drain through the join to the outerframe.

**Do Not Scale From This Drawing**

**Standard Stays**

**Detail 6A**



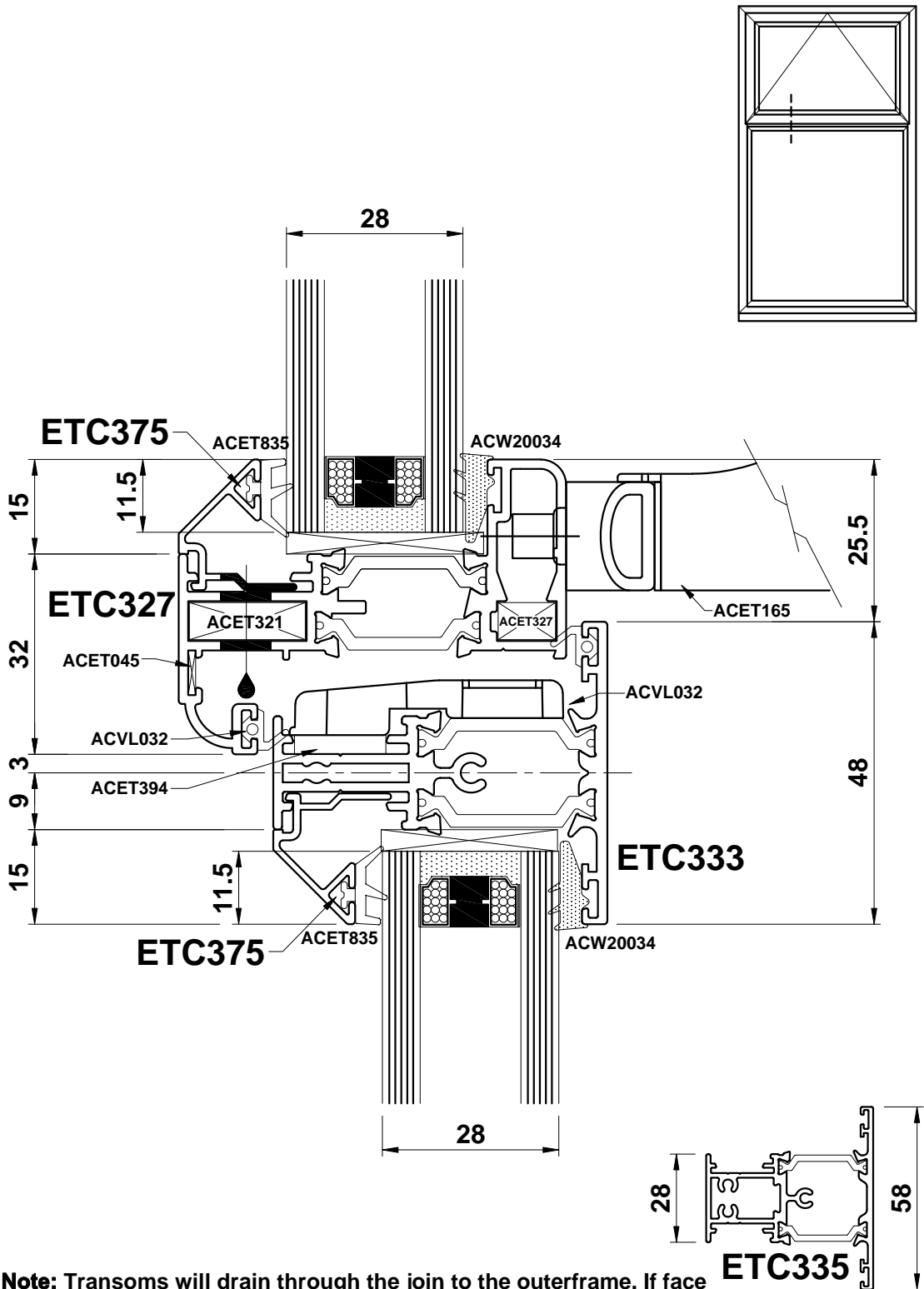
**Note:** Transoms will drain through the joint to the outerframe. If face drainage is preferred, wider transom ETC335 must be used.

**Do Not Scale From This Drawing**



Standard Stays

Detail 6B

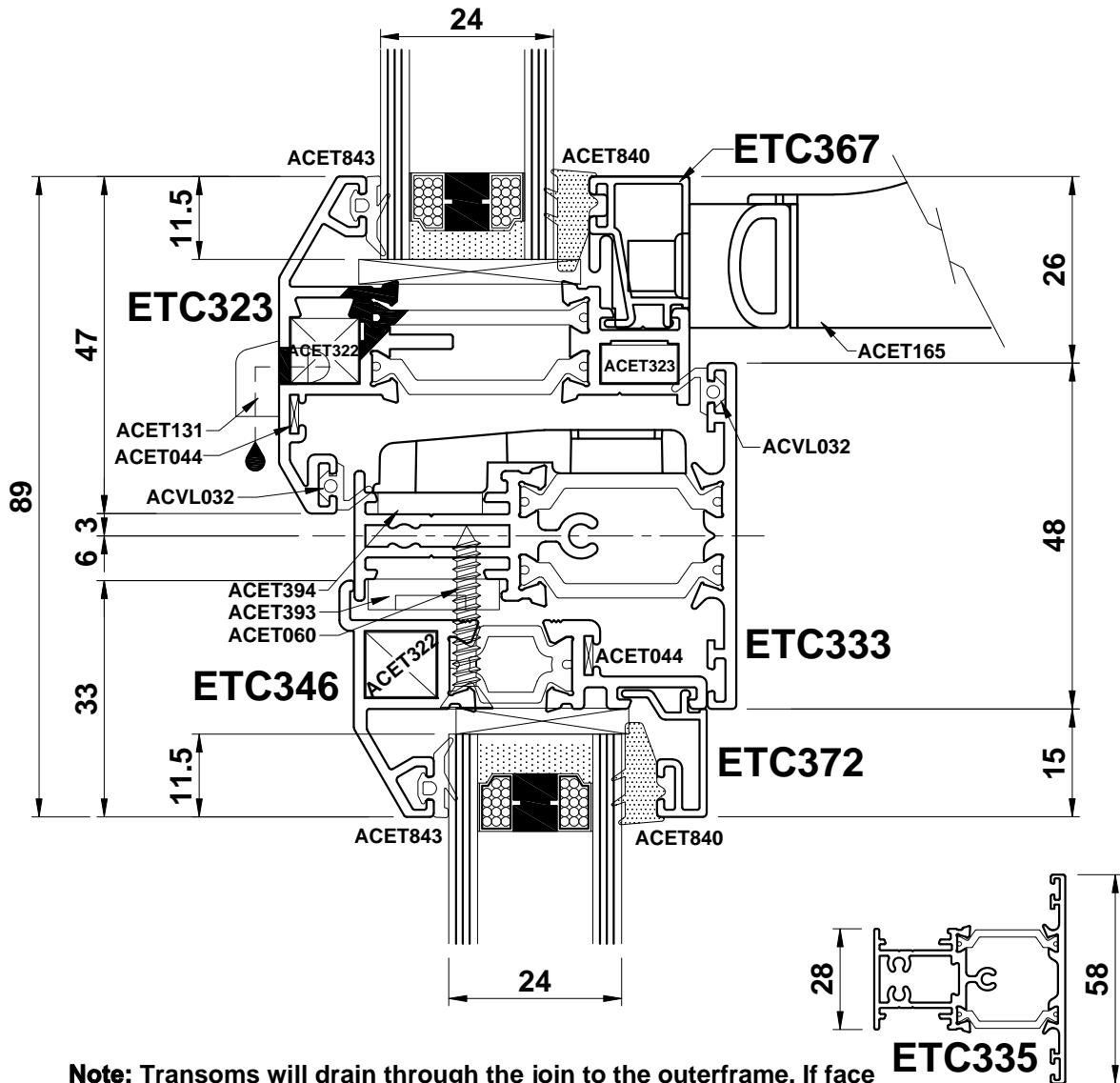
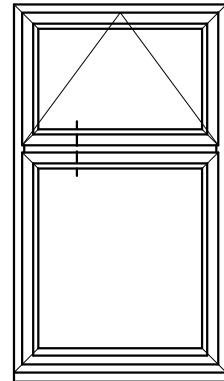


**Note:** Transoms will drain through the join to the outerframe. If face drainage is preferred, wider transom ETC335 must be used.

Do Not Scale From This Drawing

Standard Stays

Detail 6C

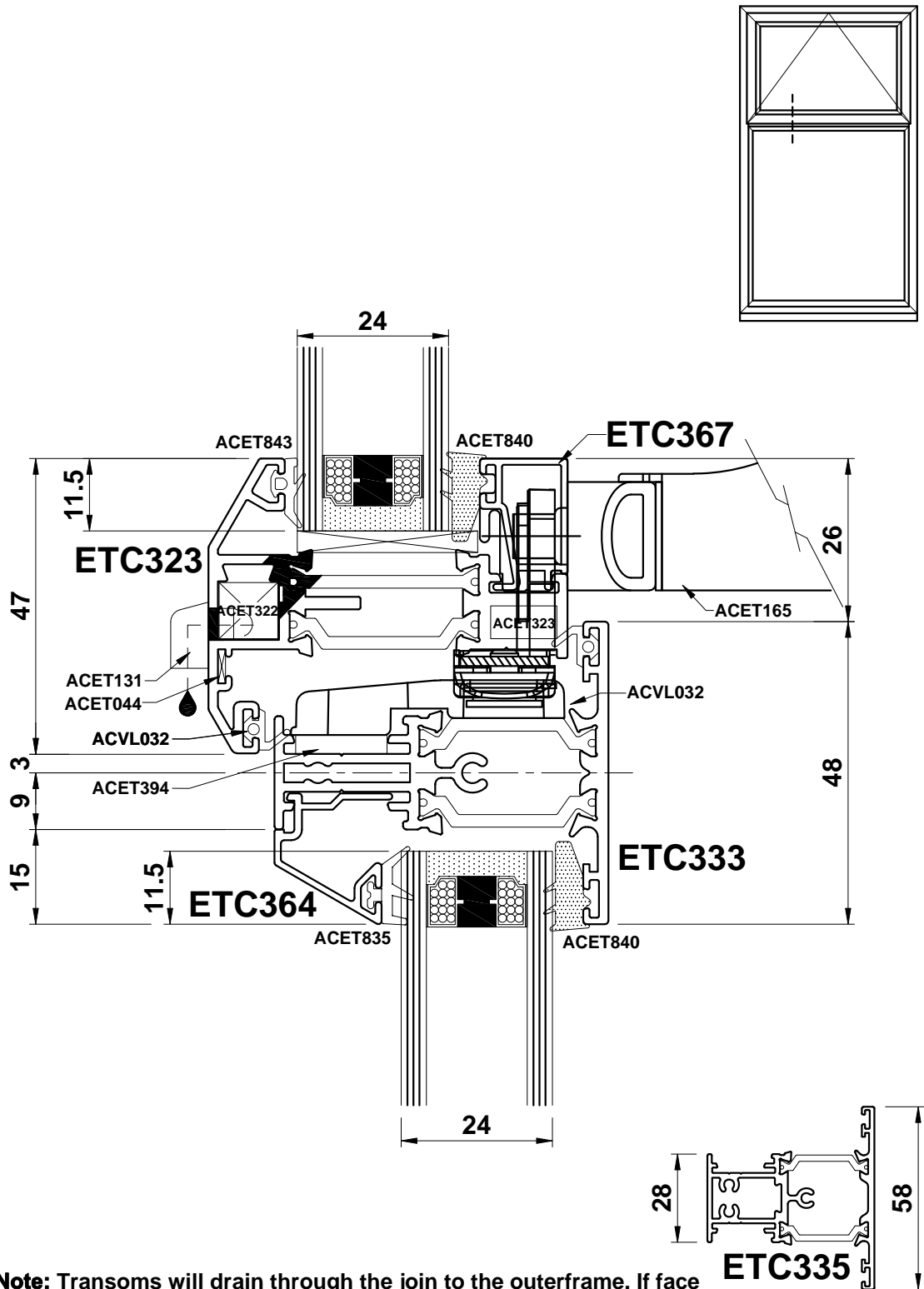


**Note:** Transoms will drain through the joint to the outerframe. If face drainage is preferred, wider transom ETC335 must be used.

**Do Not Scale From This Drawing**

Standard Stays

Detail 6D

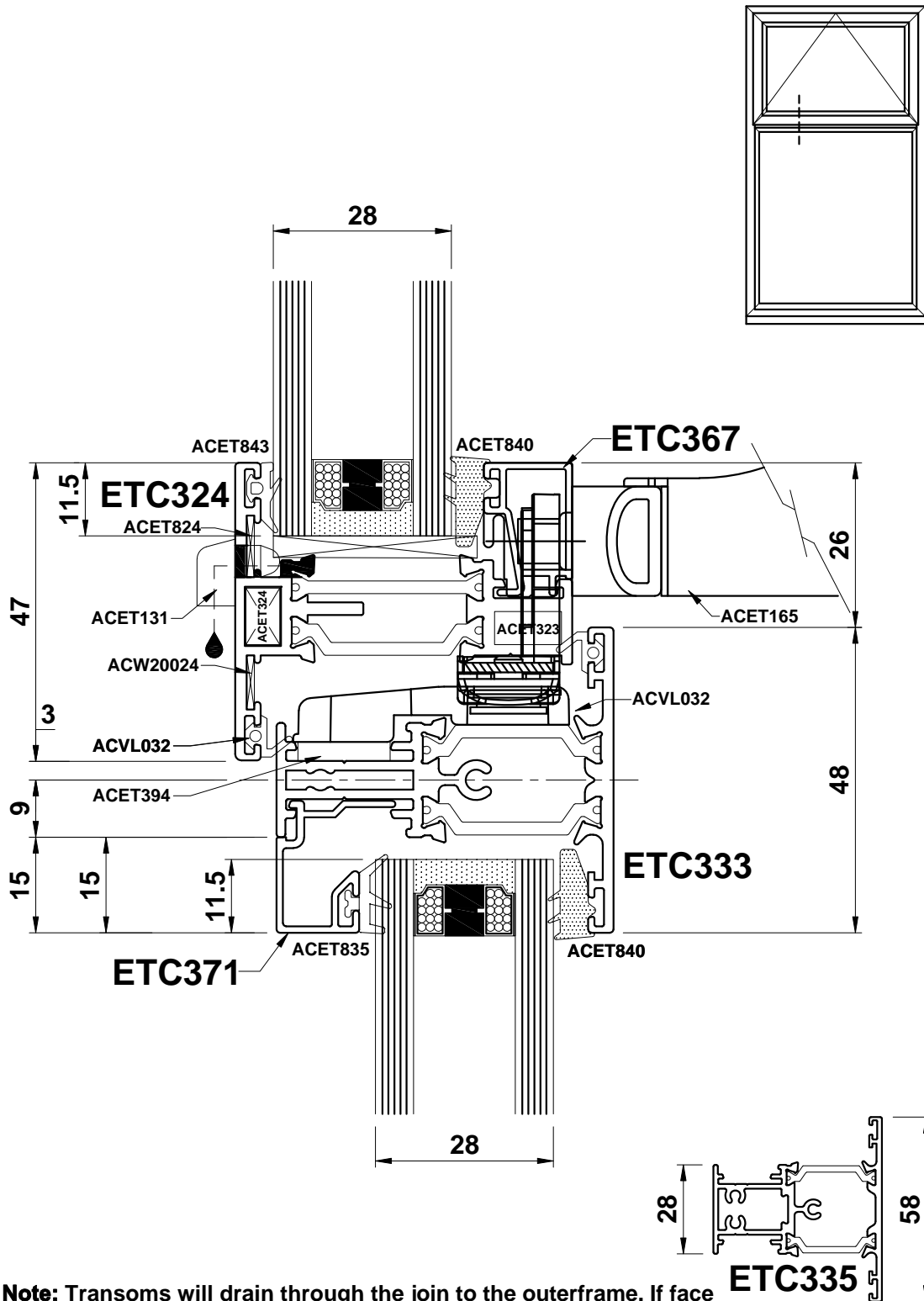


**Note:** Transoms will drain through the join to the outerframe. If face drainage is preferred, wider transom ETC335 must be used.

**Do Not Scale From This Drawing**

Standard Stays

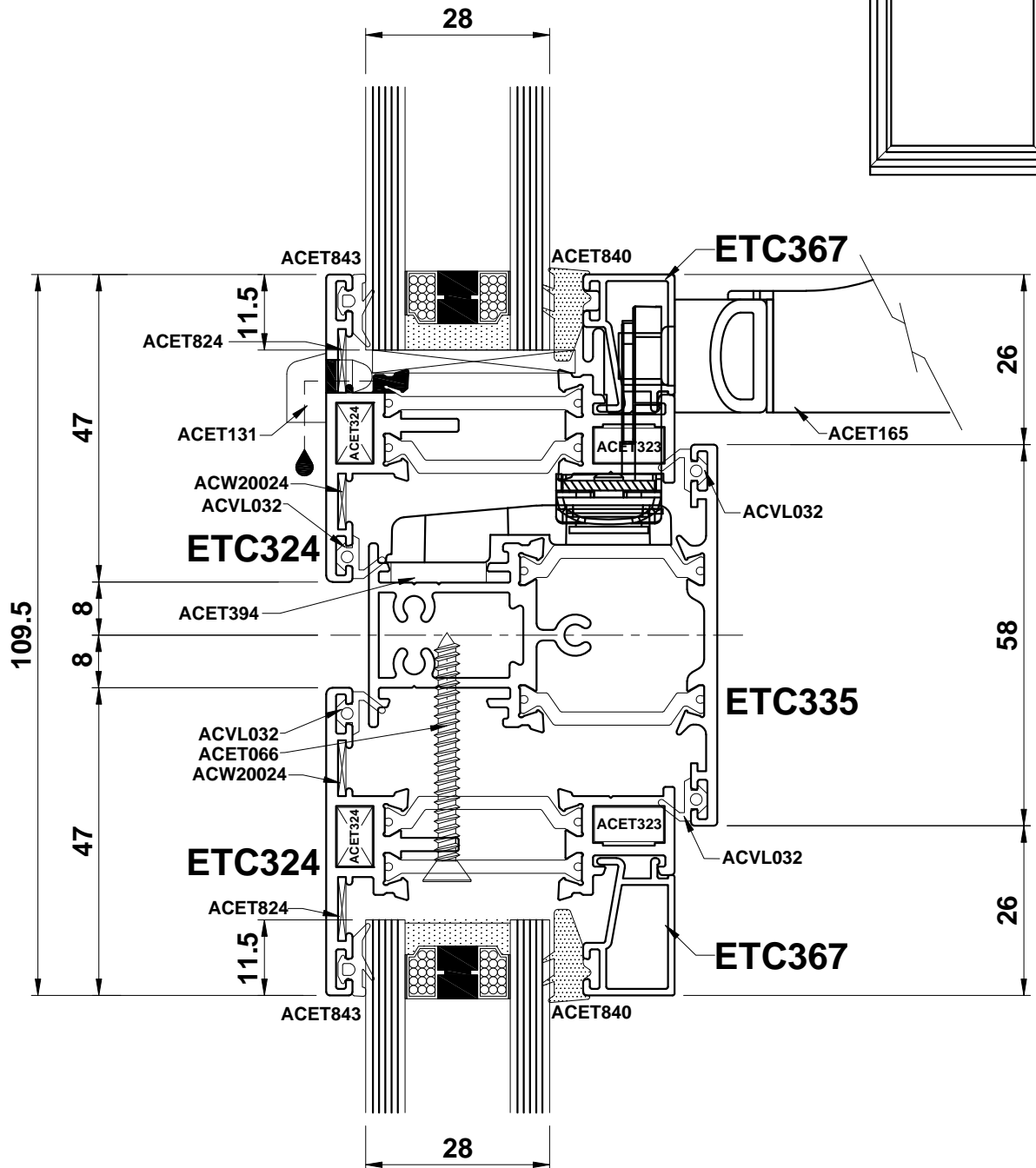
Detail 6E



Do Not Scale From This Drawing

**Standard Stays**

**Detail 7A**

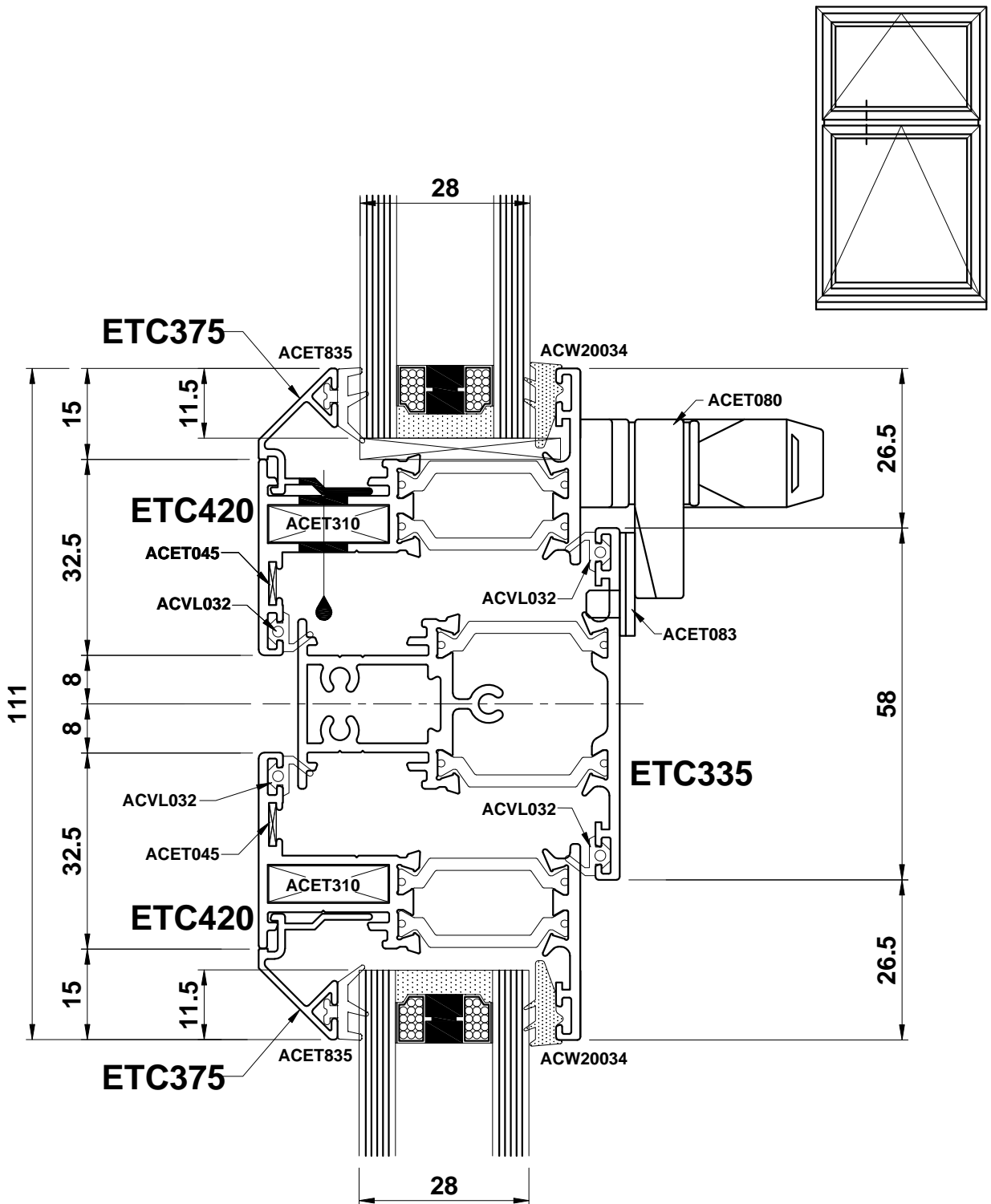


**Note:** Transoms will drain through the joint to the outerframe.

**Do Not Scale From This Drawing**

**Standard Stays**

**Detail 7B**

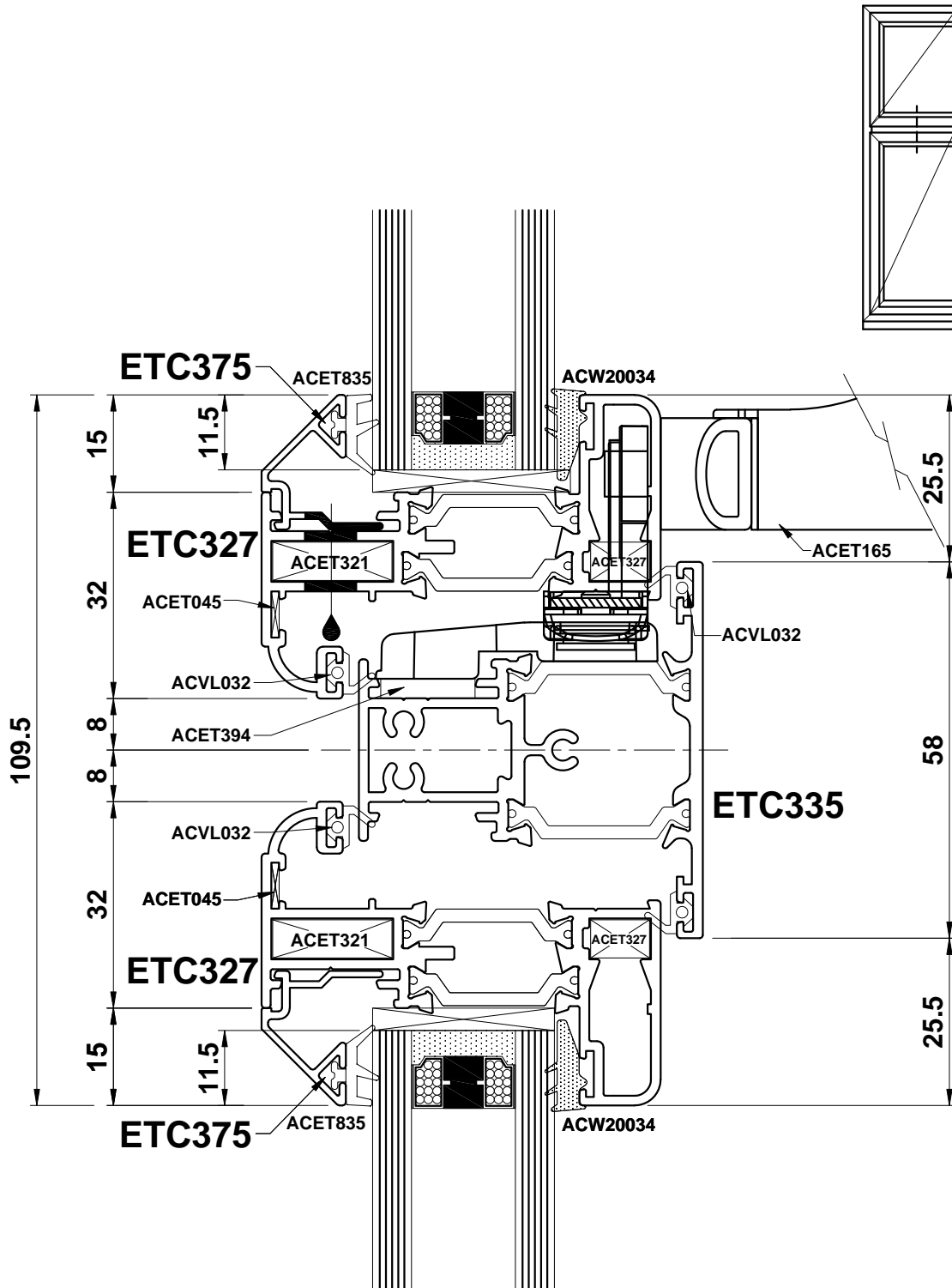


**Note:** Transoms will drain through the join to the outerframe.

**Do Not Scale From This Drawing**

**Standard Stays**

**Detail 7C**

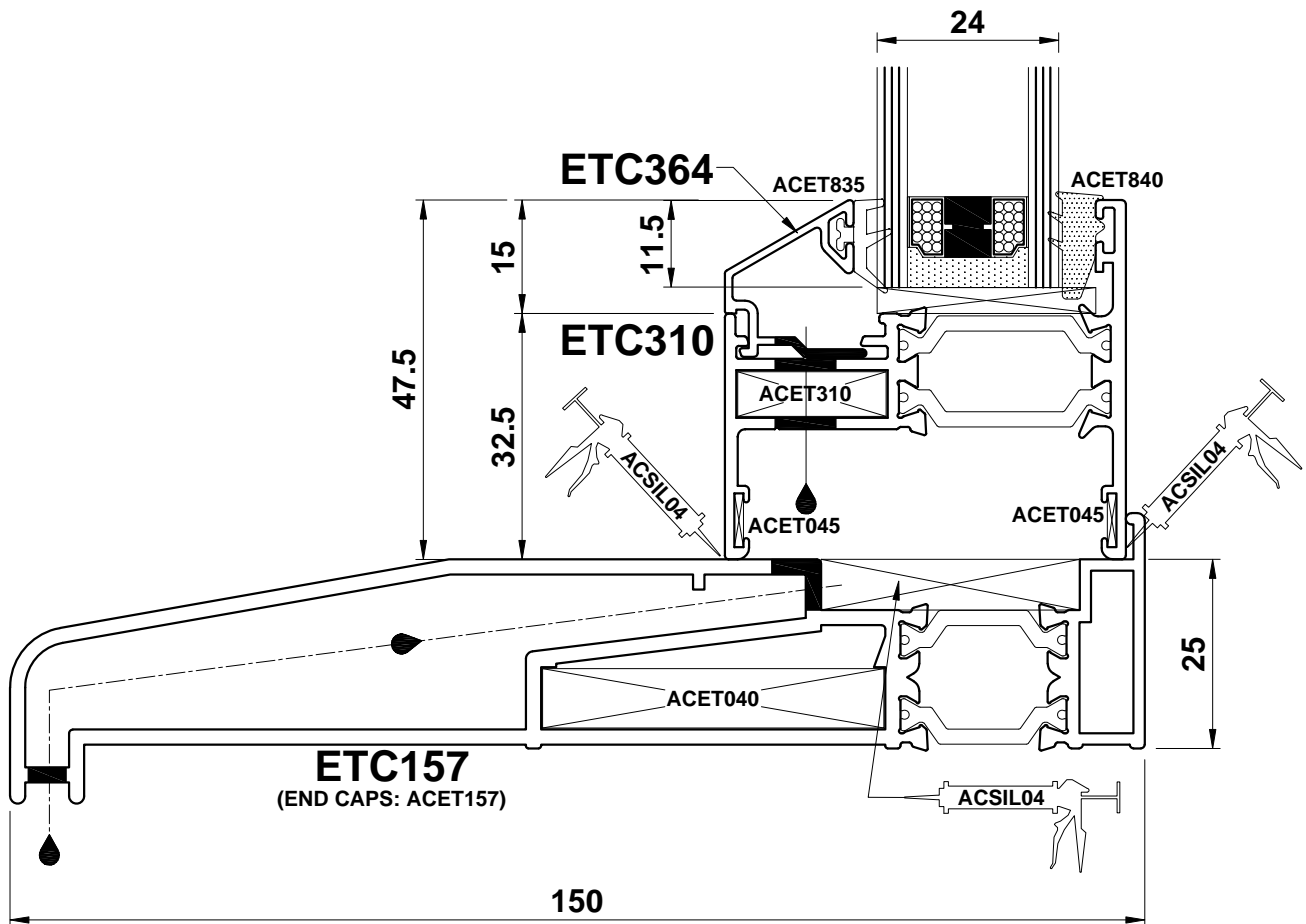
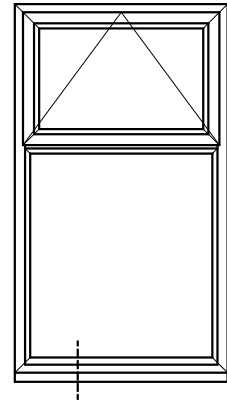


**Note:** Transoms will drain through the joint to the outerframe.

**Do Not Scale From This Drawing**

Standard Stays

Detail 8A



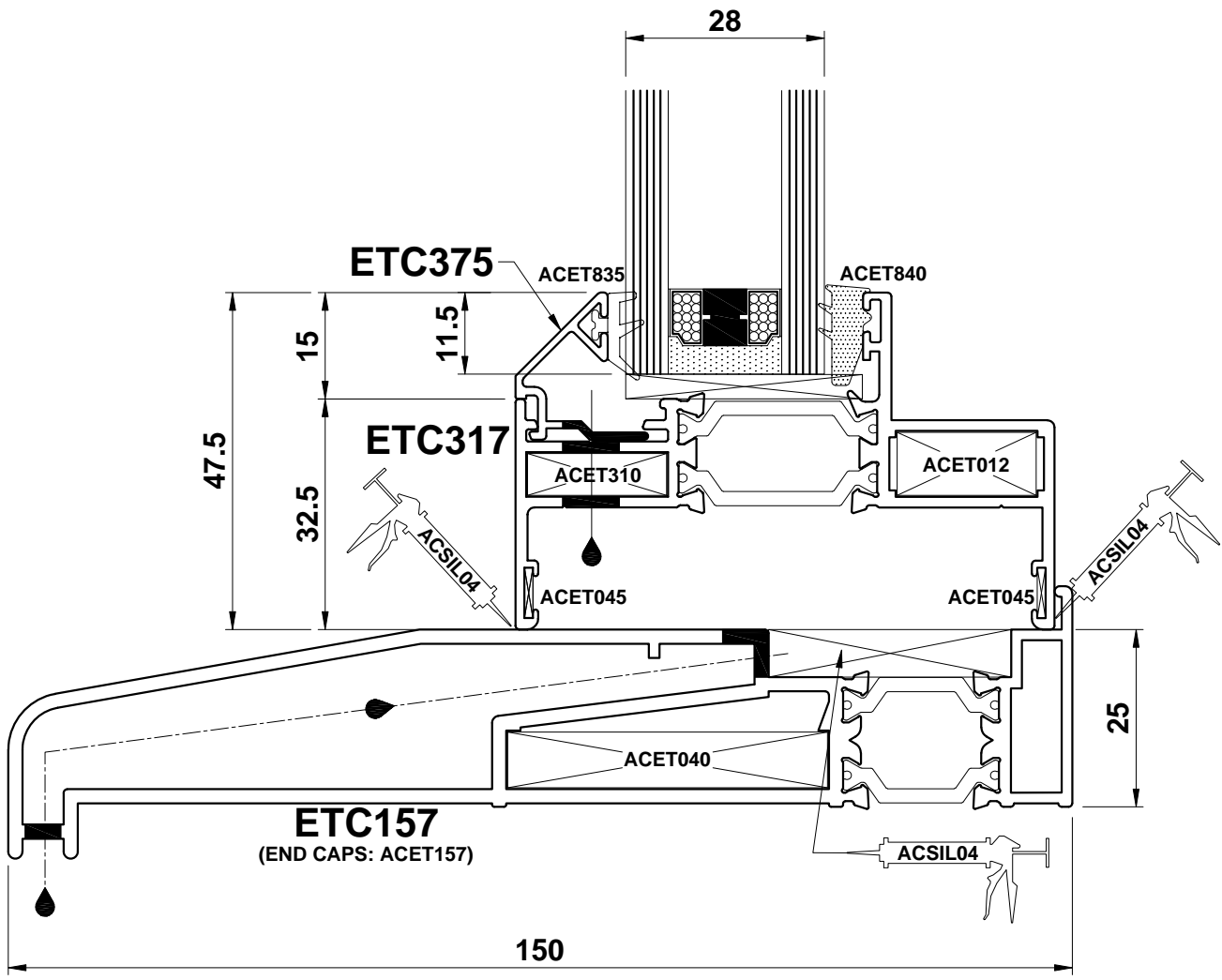
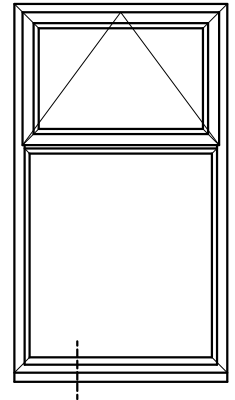
Cill end caps should be sealed to cill to prevent water egress over edge

Do Not Scale From This Drawing



Standard Stays

Detail 8B

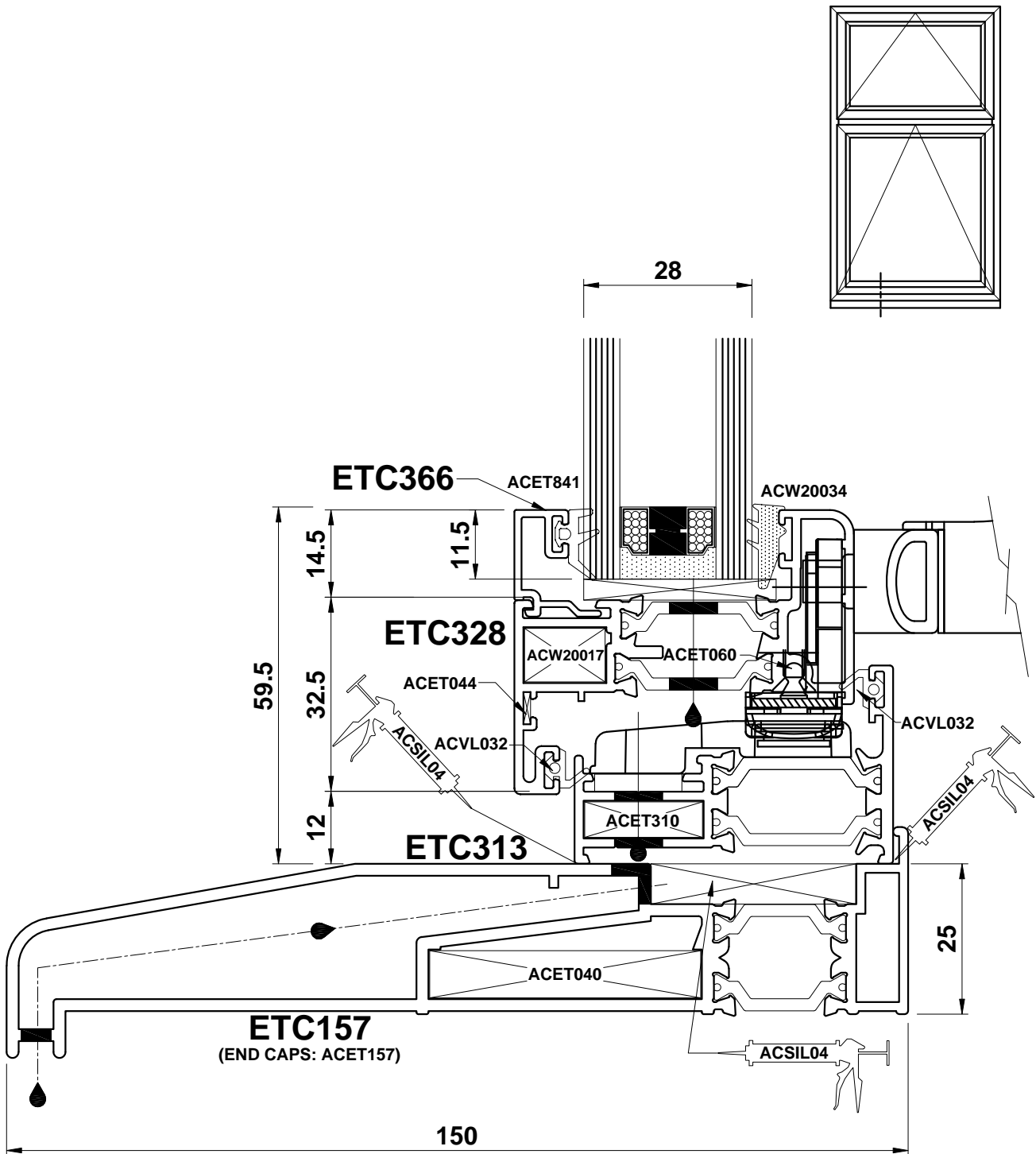


Cill end caps should be sealed to cill to prevent water egress over edge

Do Not Scale From This Drawing

Standard Stays

Detail 9A

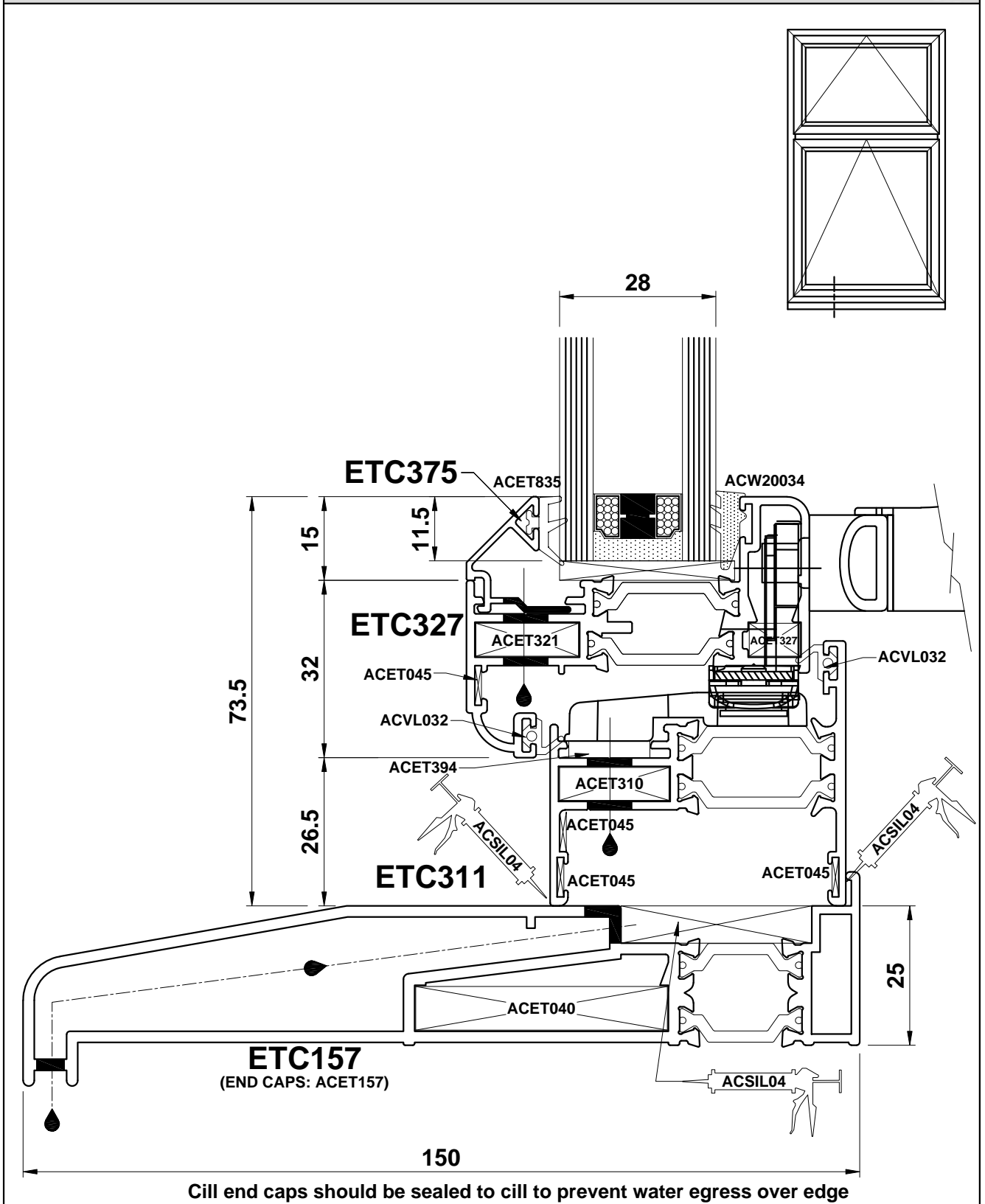


Cill end caps should be sealed to cill to prevent water egress over edge

Do Not Scale From This Drawing

Standard Stays

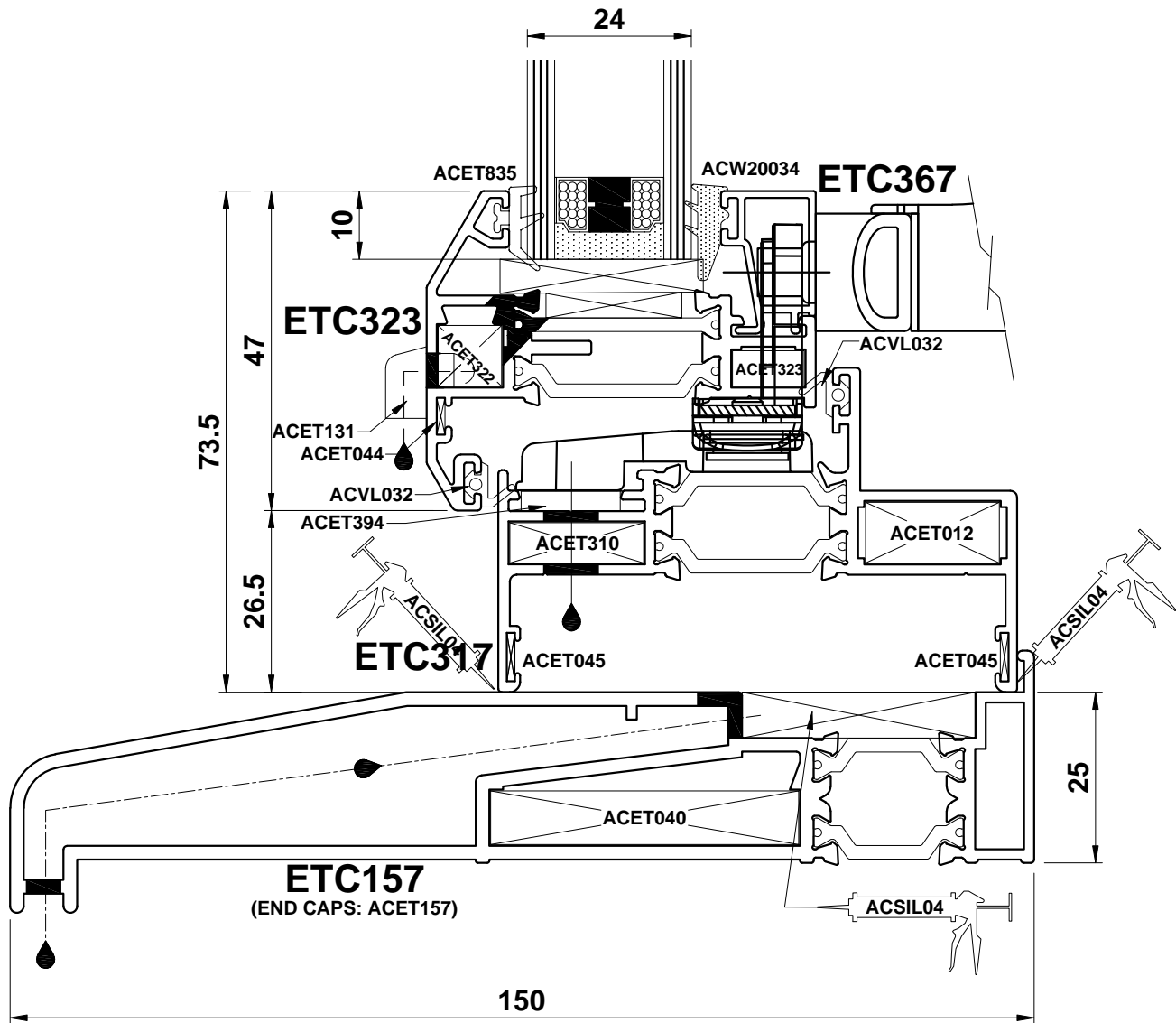
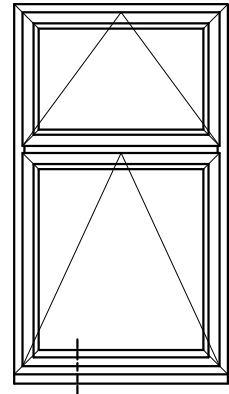
Detail 9B



Do Not Scale From This Drawing

**Standard Stays**

**Detail 9C**

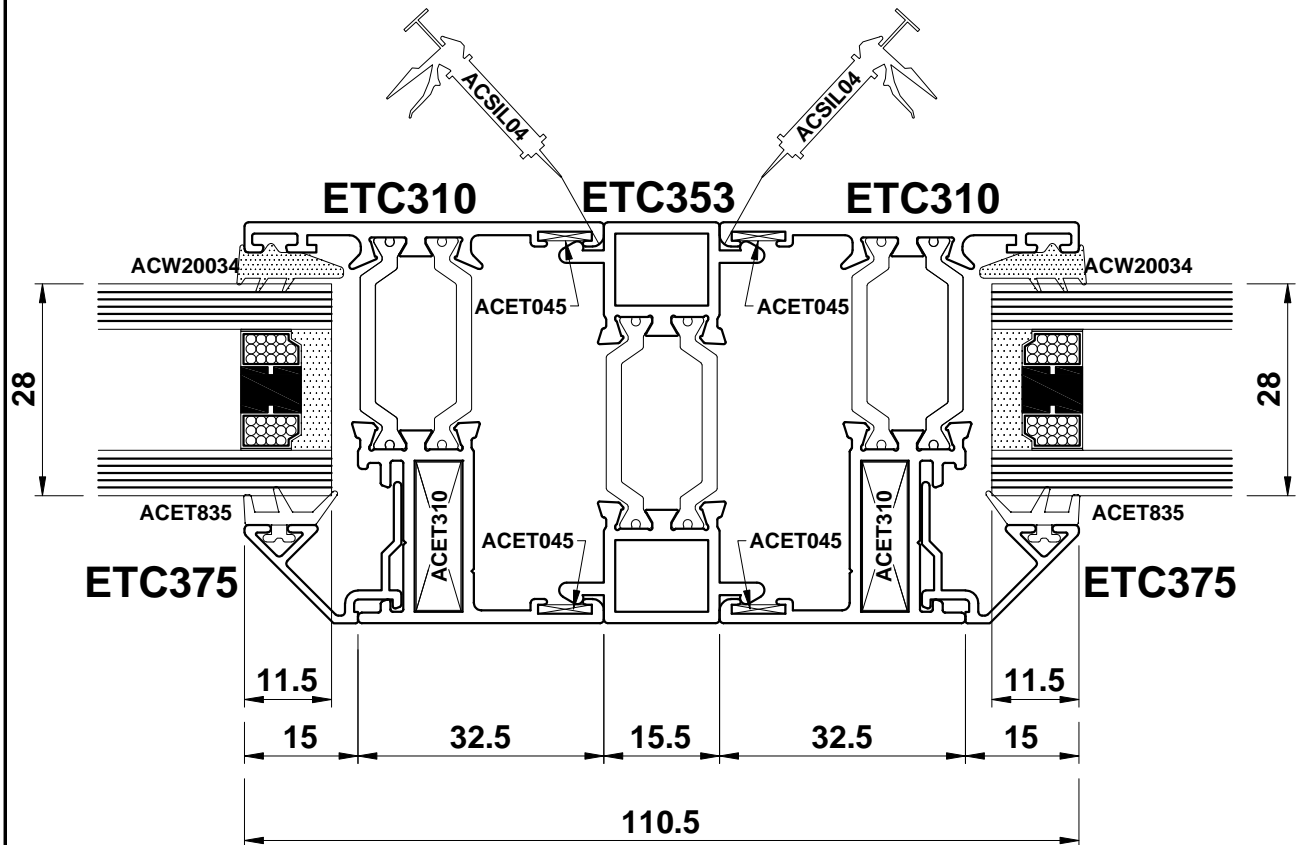
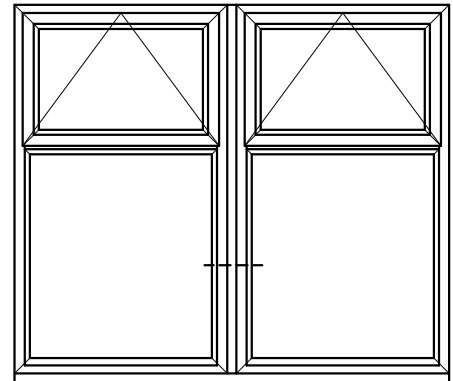


Cill end caps should be sealed to cill to prevent water egress over edge

**Do Not Scale From This Drawing**

**Standard Stays**

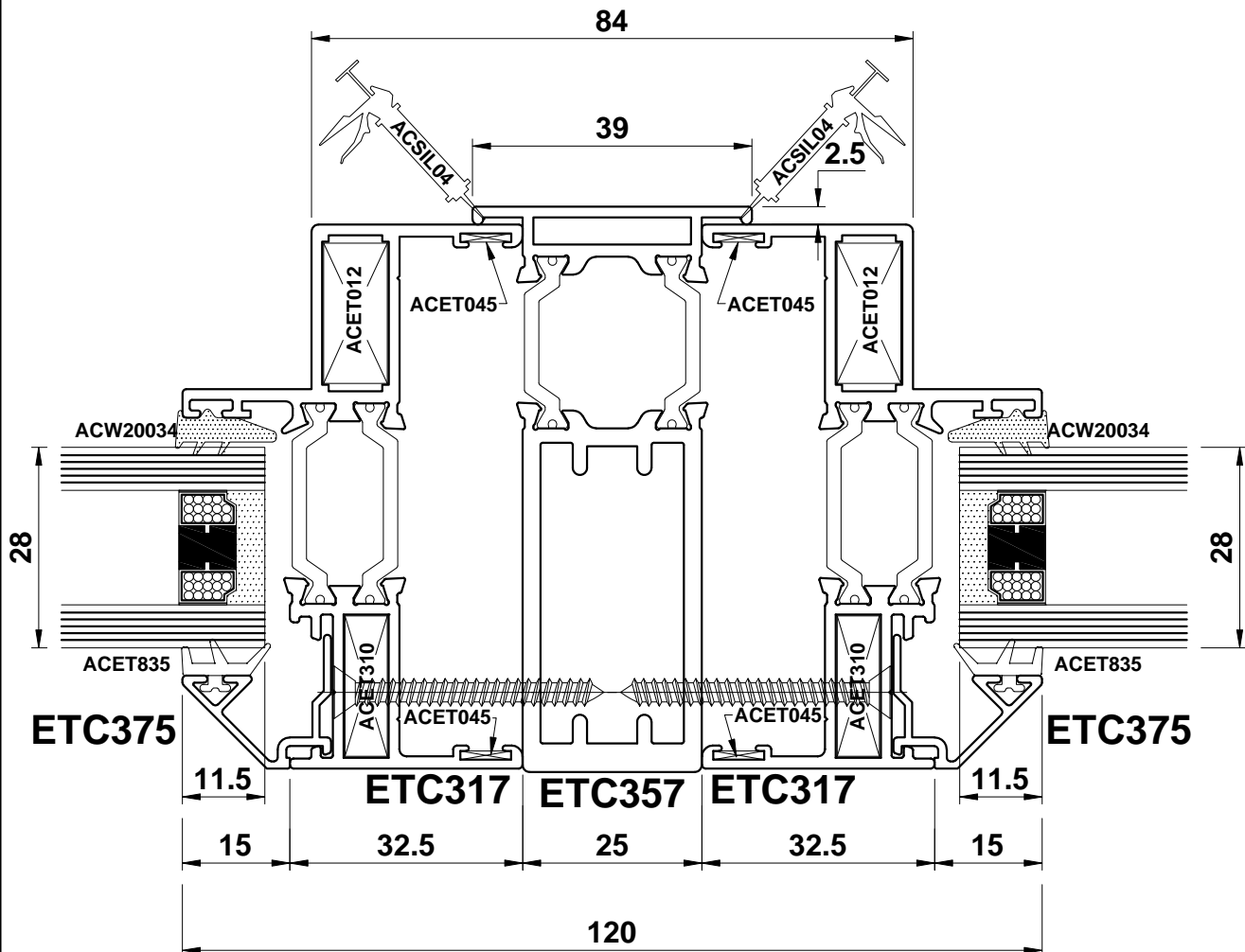
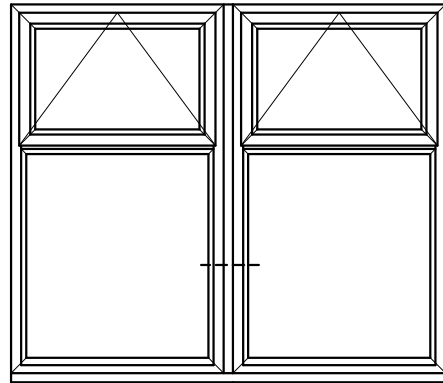
**Detail 10A**



**Do Not Scale From This Drawing**

**Standard Stays**

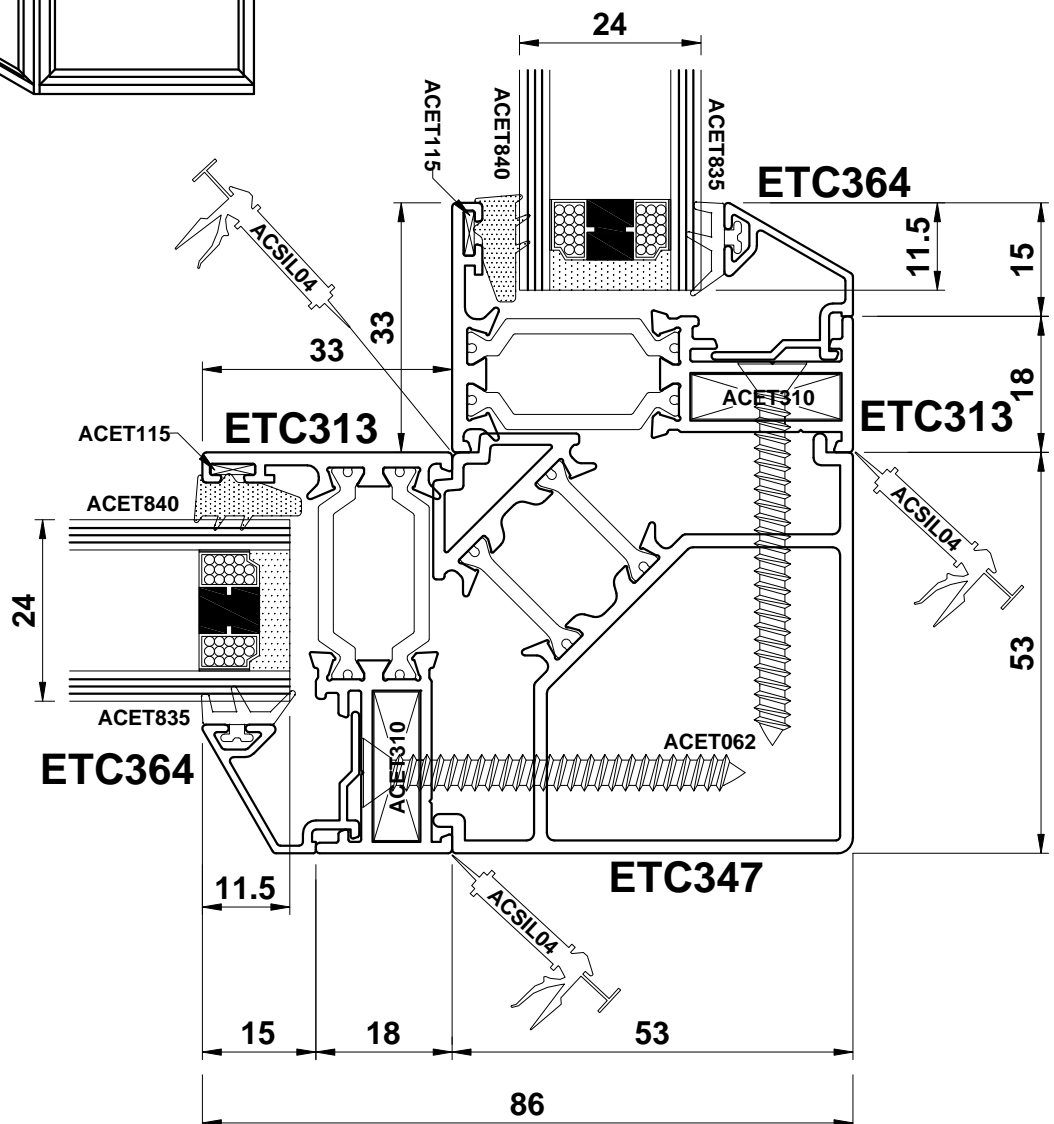
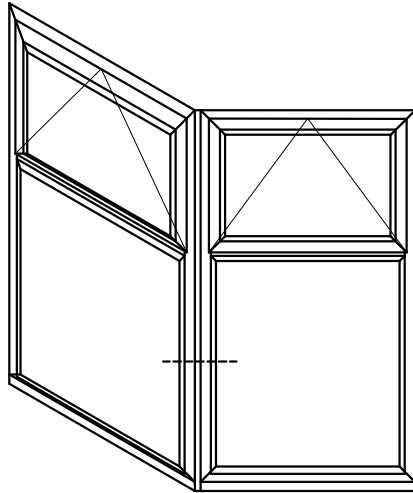
**Detail 10B**



**Do Not Scale From This Drawing**

**Standard Stays**

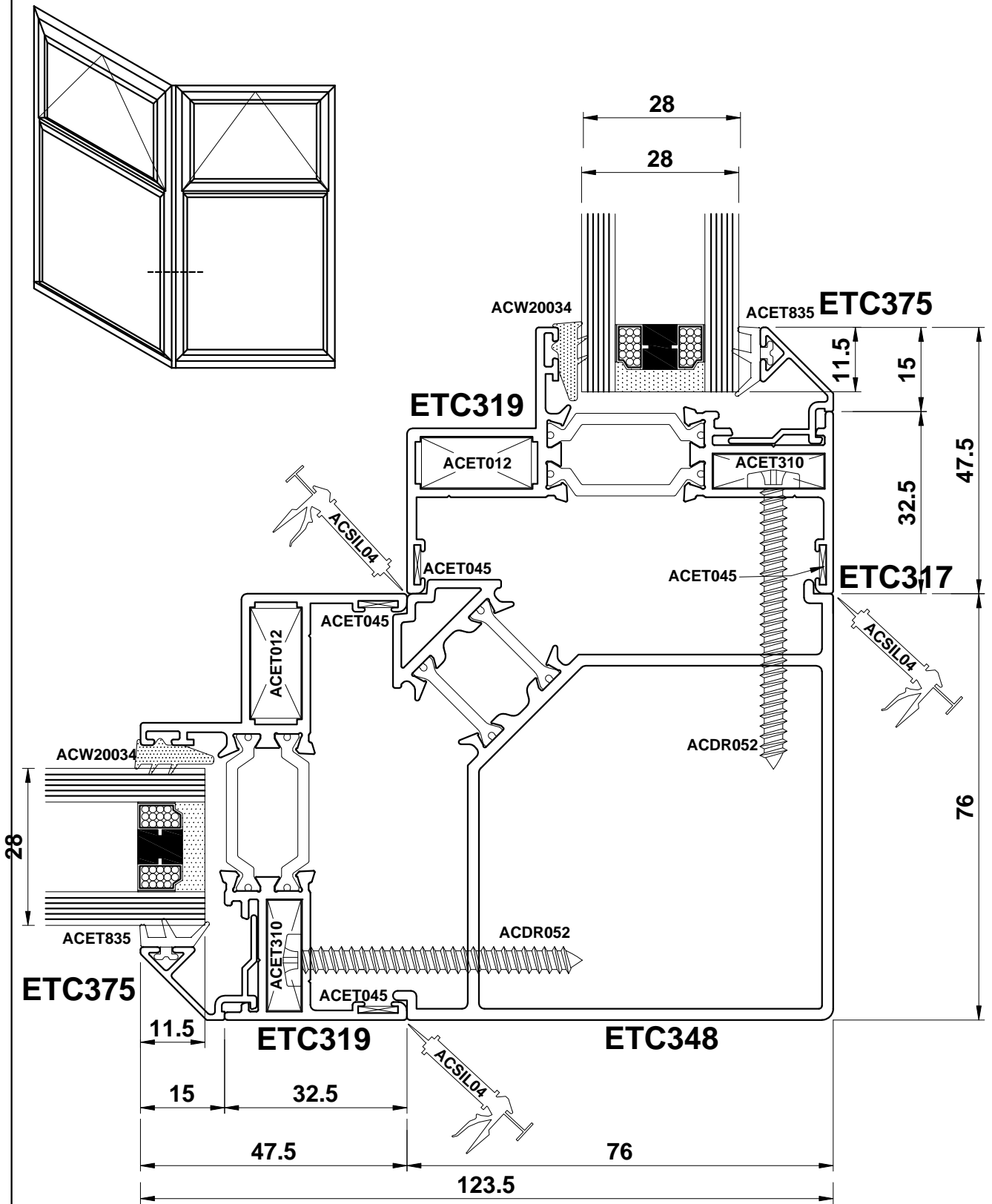
**Detail 10C**



**Do Not Scale From This Drawing**

**Standard Stays**

**Detail 10D**

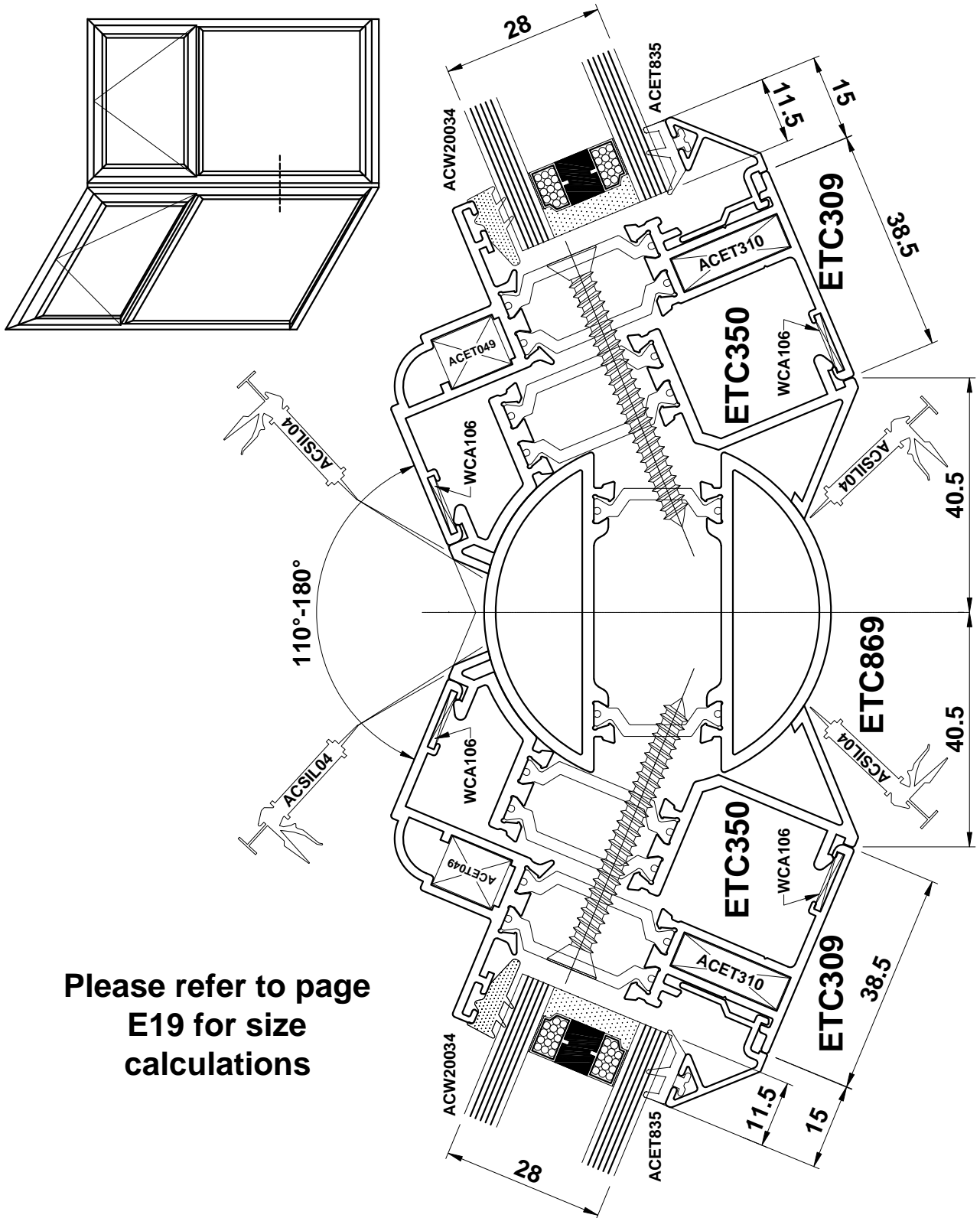


**Do Not Scale From This Drawing**



**Standard Stays**

**Detail 10E**



Please refer to page  
E19 for size  
calculations

**Do Not Scale From This Drawing**

**Section D**

## Standard Stays

**For Wind Loading Limitations,  
Please Contact  
The Technical Department.**

**Do Not Scale From This Drawing**

Section E

**Alitherm 300  
Standard Stays  
Construction Drawings**

**Index**

**E ETC**

**Construction Drawings**

**E 1**

1 - Corner Jointing ..... Page E02 - E04

**E 2**

2 - Drainage ..... Page E05 - E06

**E 3**

3 - Transom/Mullion Preparation ..... Page E07 - E09

**E 4**

4 - Hinges ..... Page E10

**E 5**

5 - Locking Hardware ..... Page E11 - E13

**E 6**

6 - Beading & Glazing ..... Page E14 - E16

**E 7**

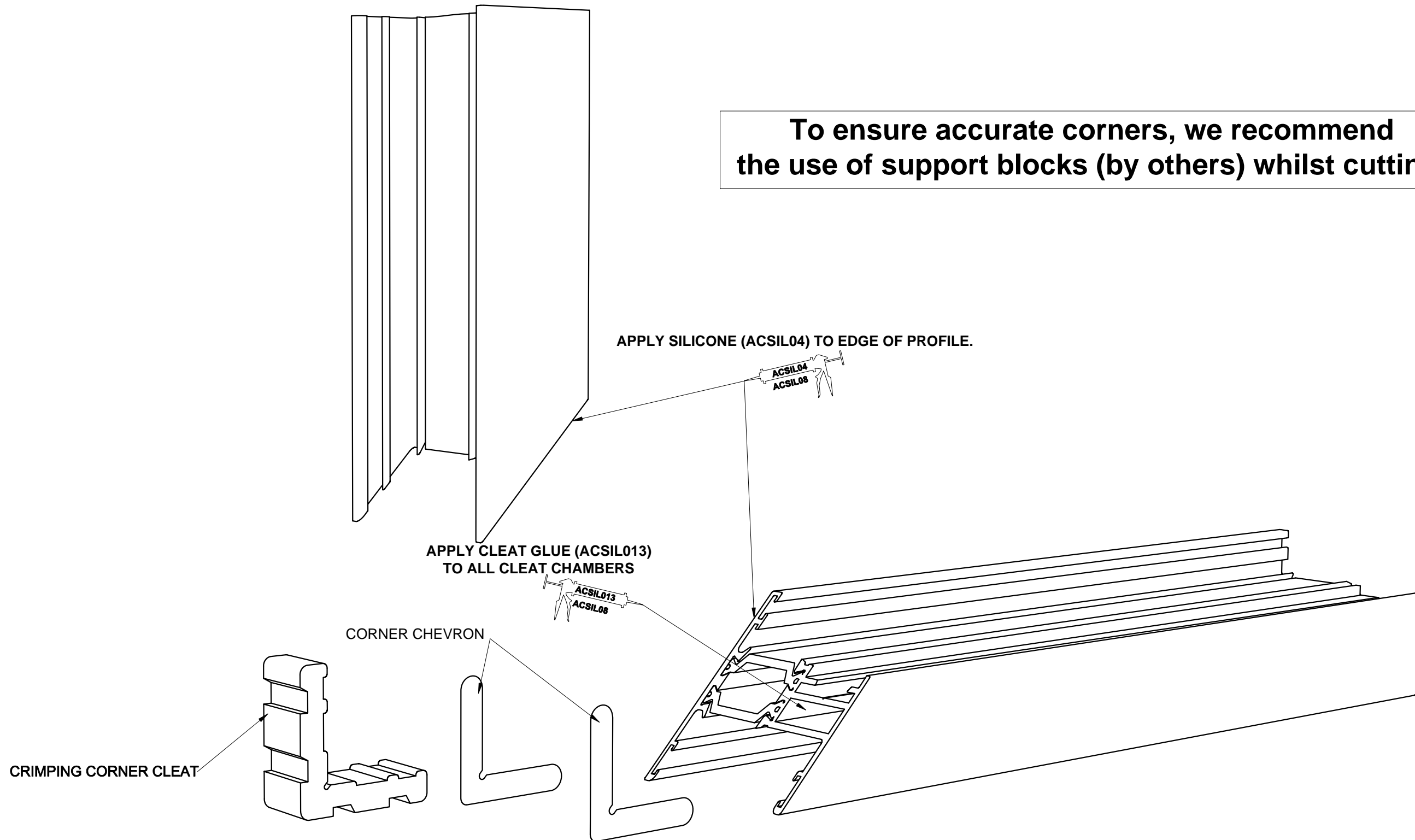
7 - Coupling/Bay Poles ..... Page E17 - E18

**IF IN DOUBT ASK!**

Typical Corner Detail

Standard Stays

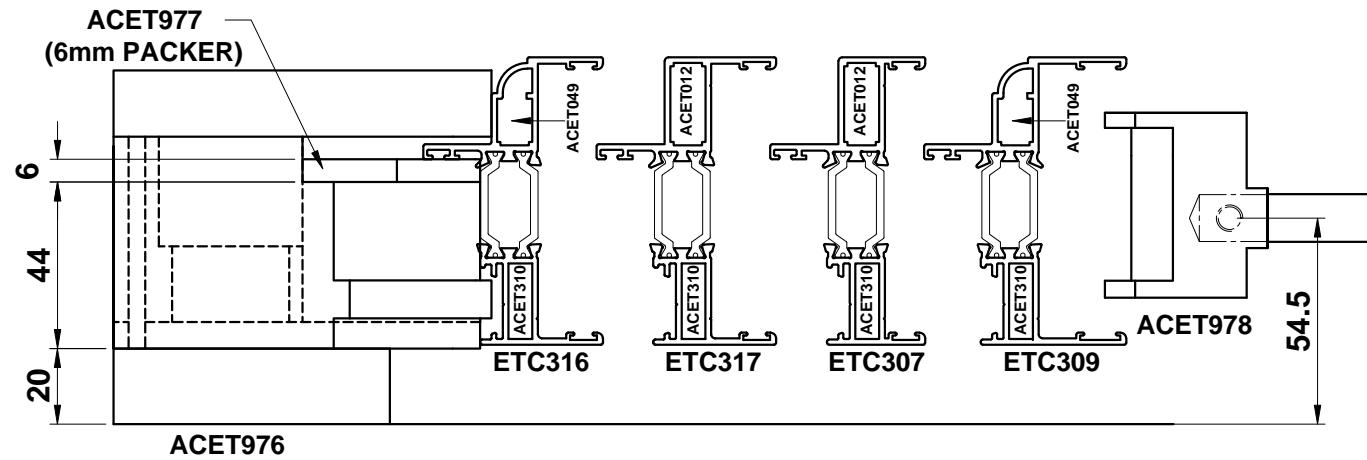
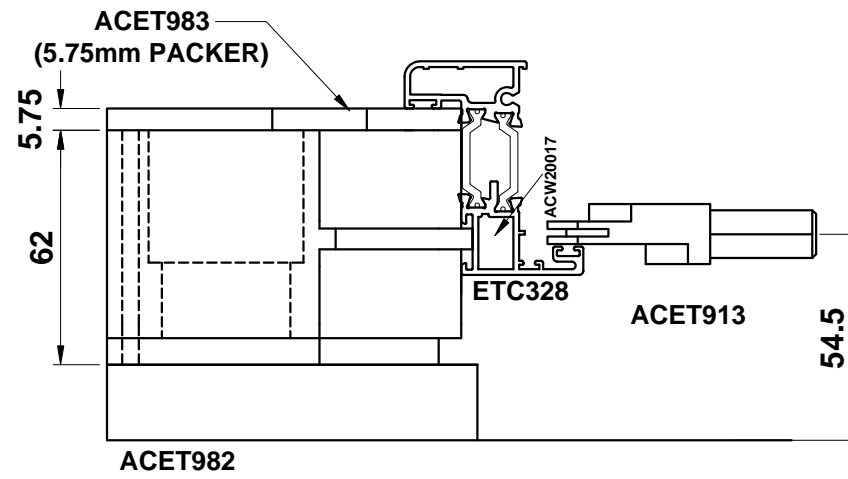
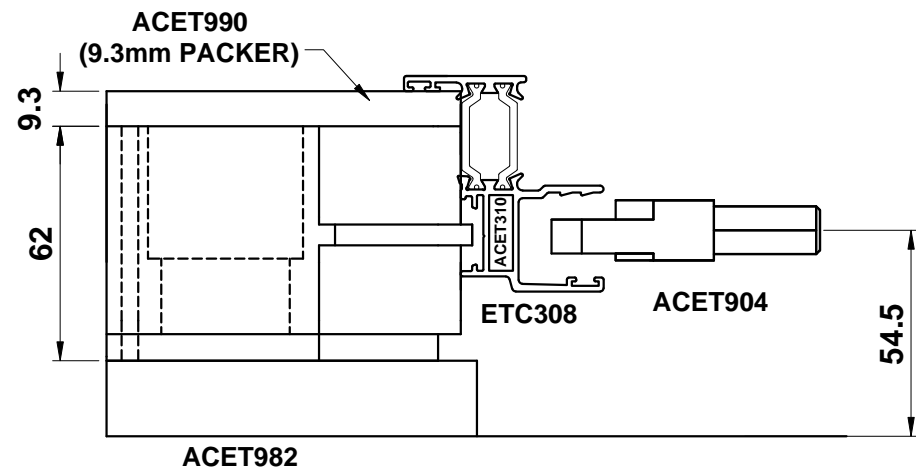
To ensure accurate corners, we recommend the use of support blocks (by others) whilst cutting.



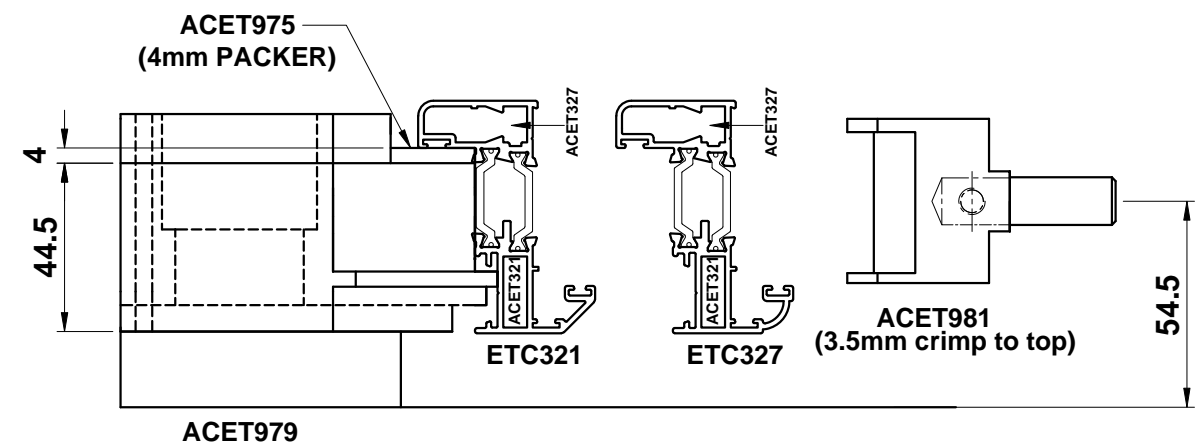
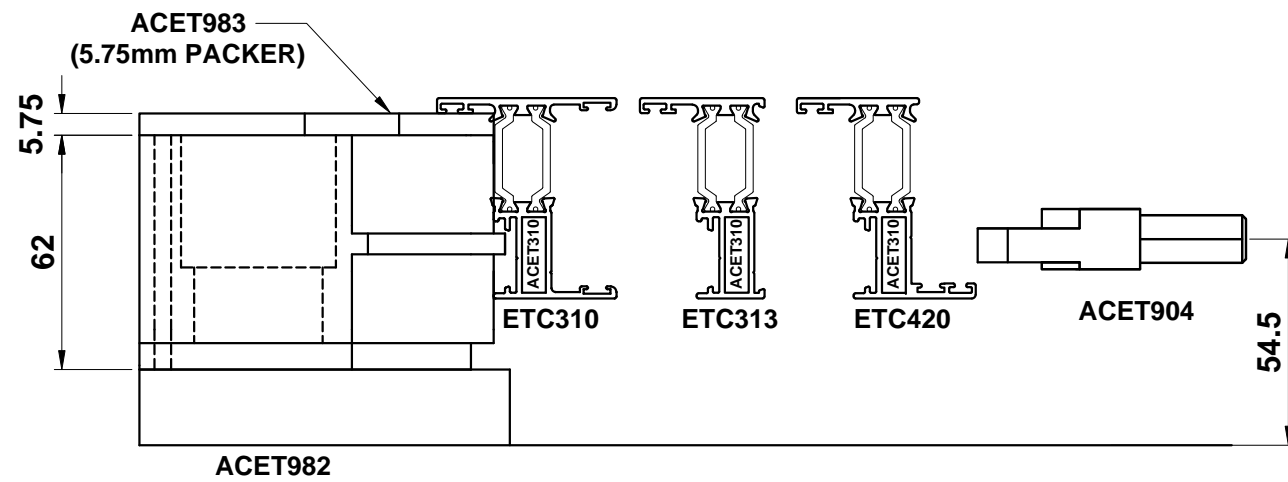
Do Not Scale From This Drawing

Corner Crimping - Externally Glazed Sections

Standard Stays



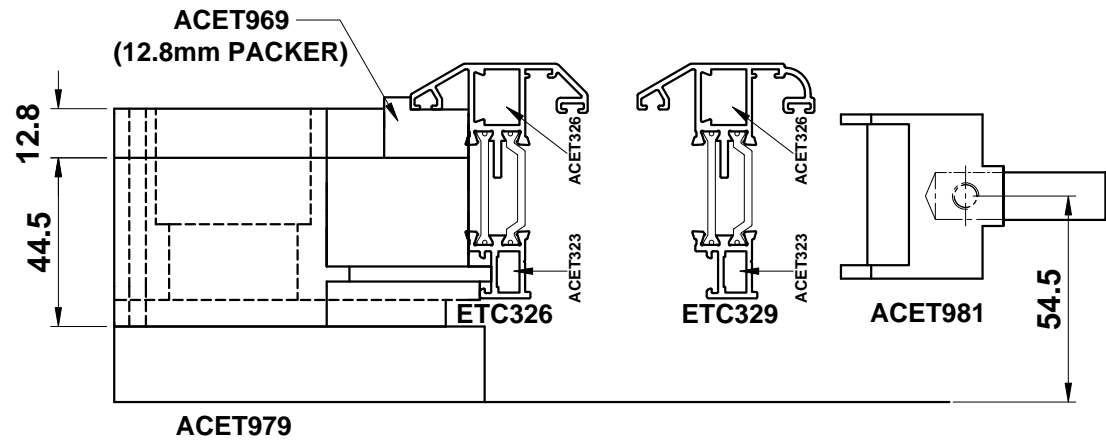
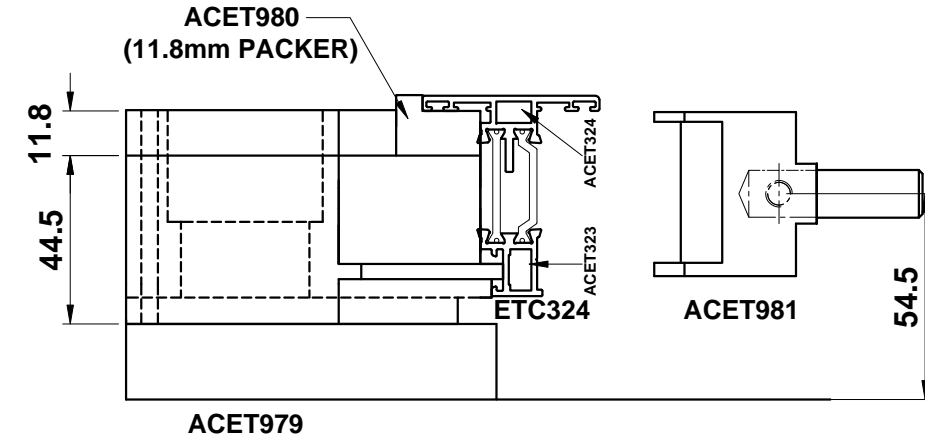
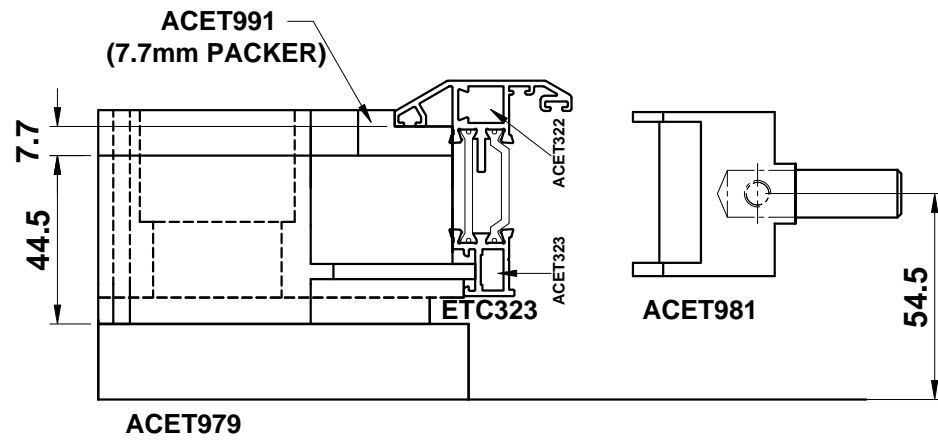
Manual Crimper = WUT024HSZA



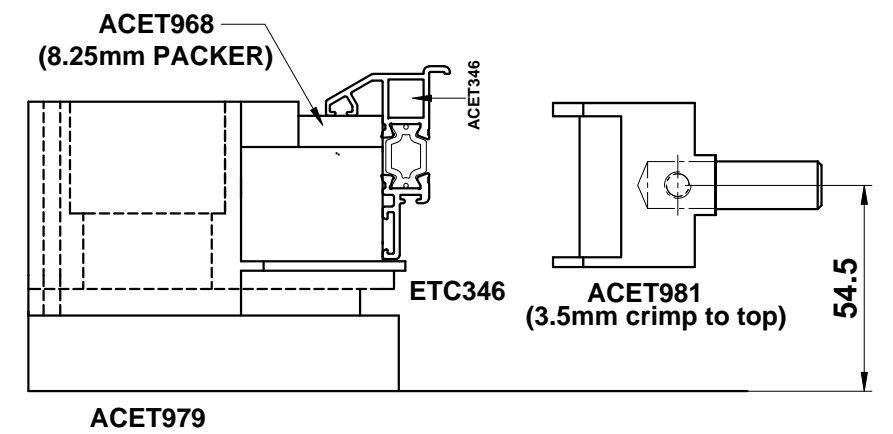
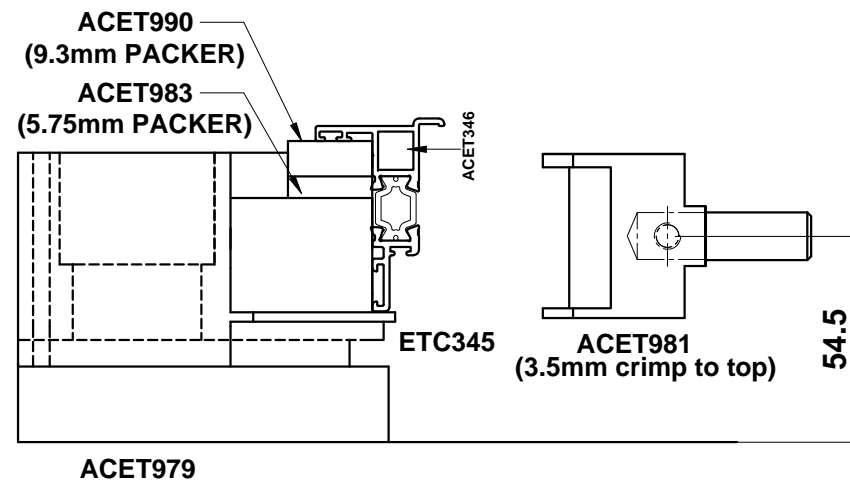
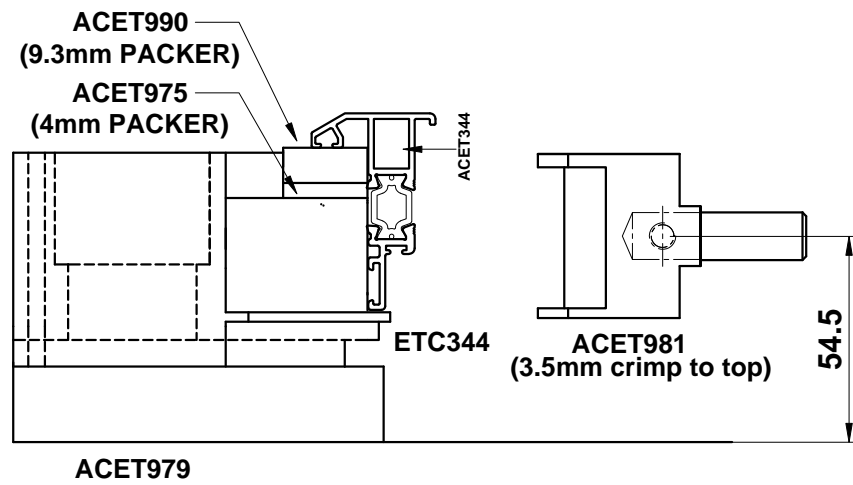
Do Not Scale From This Drawing

Corner Crimping - Internally Glazed Sections

Standard Stays

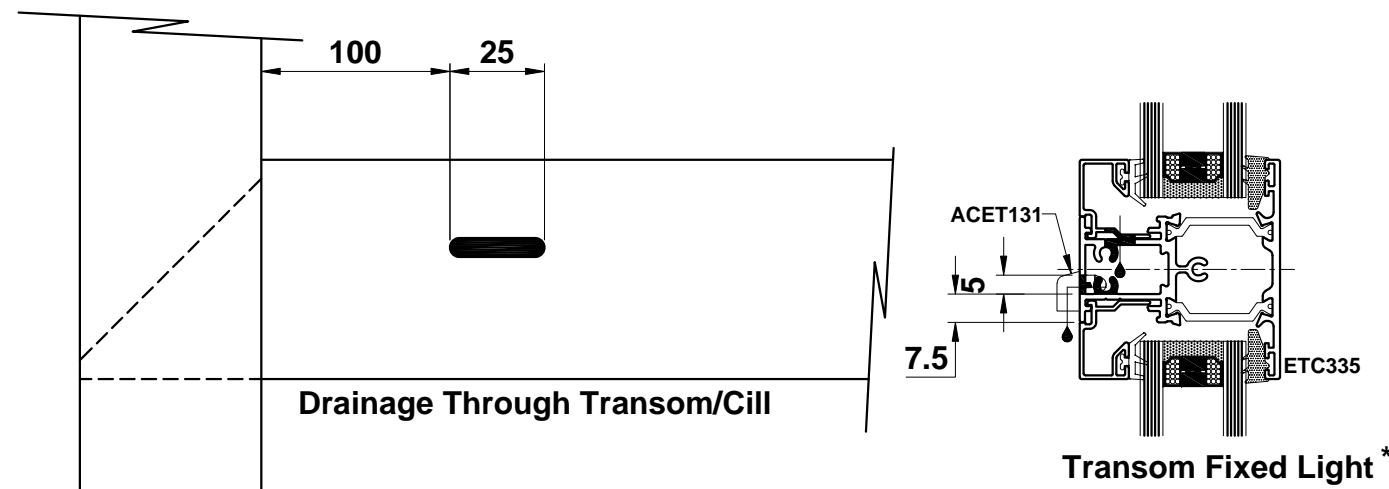


Manual Crimper = WUT024HSZA

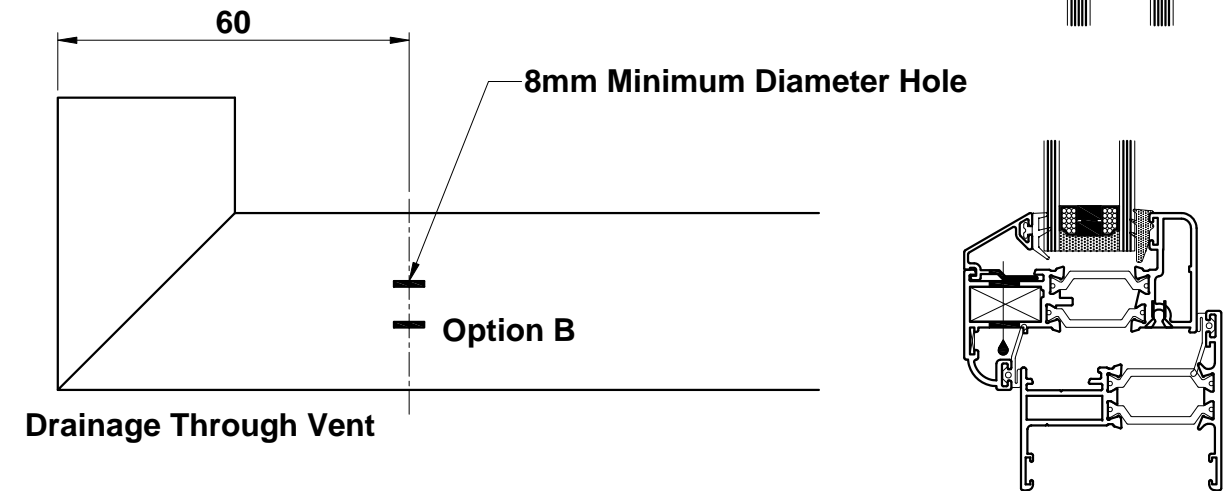
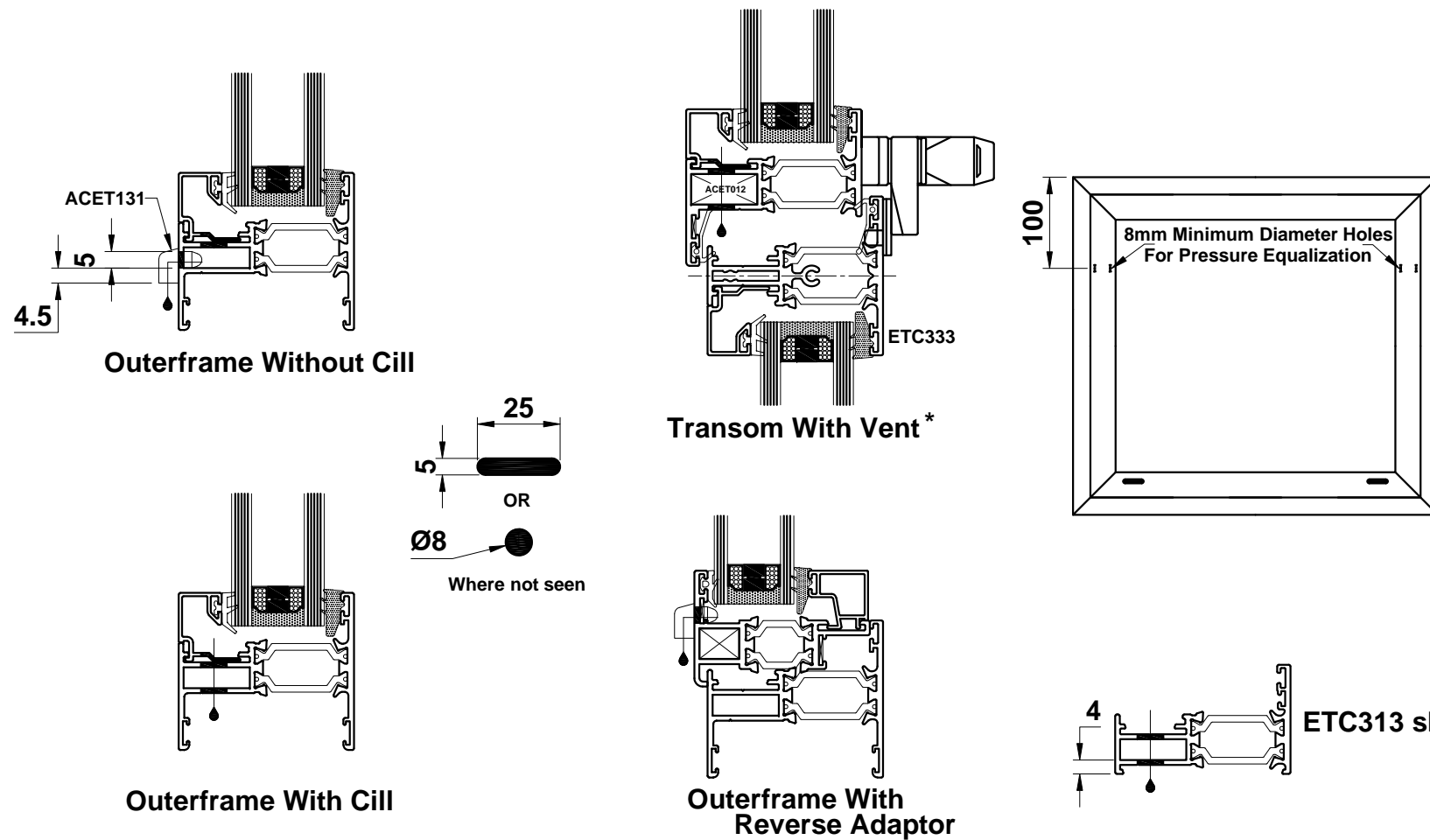
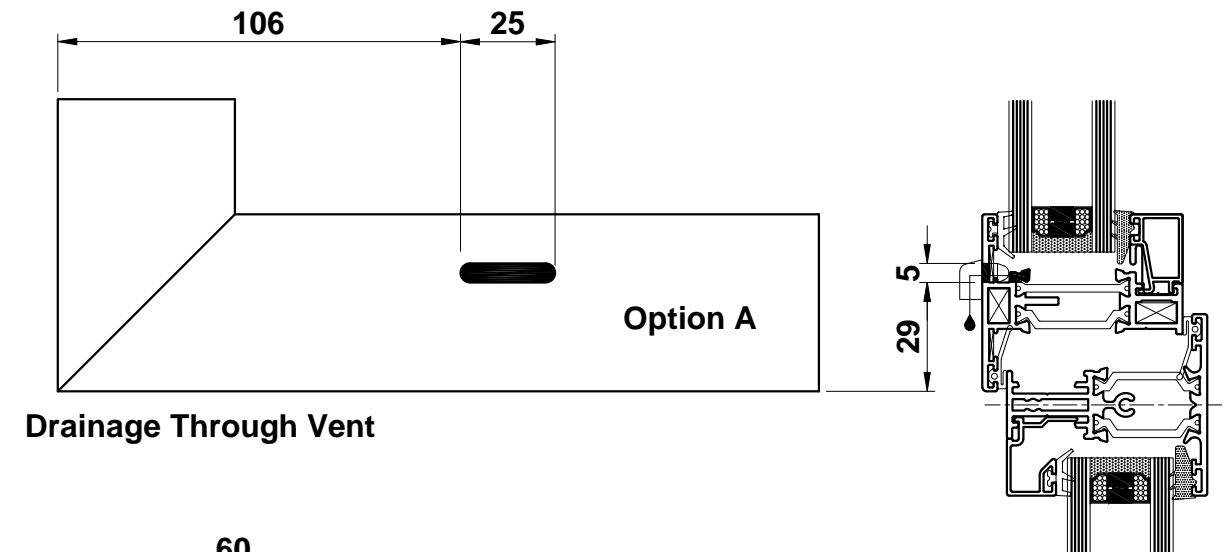


Do Not Scale From This Drawing

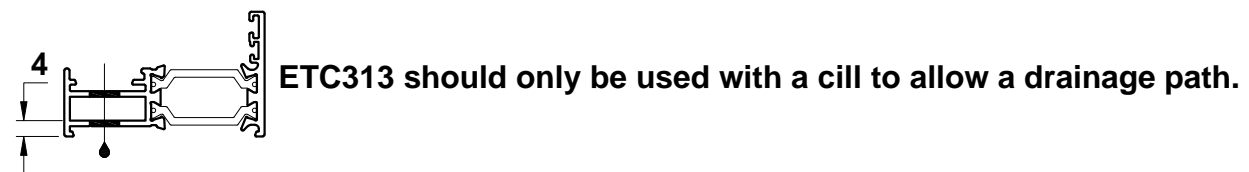
Standard Stays



\* **Note:** Transoms will drain through the join to the outerframe. If face drainage is preferred, wider transom ETC335 must be used.

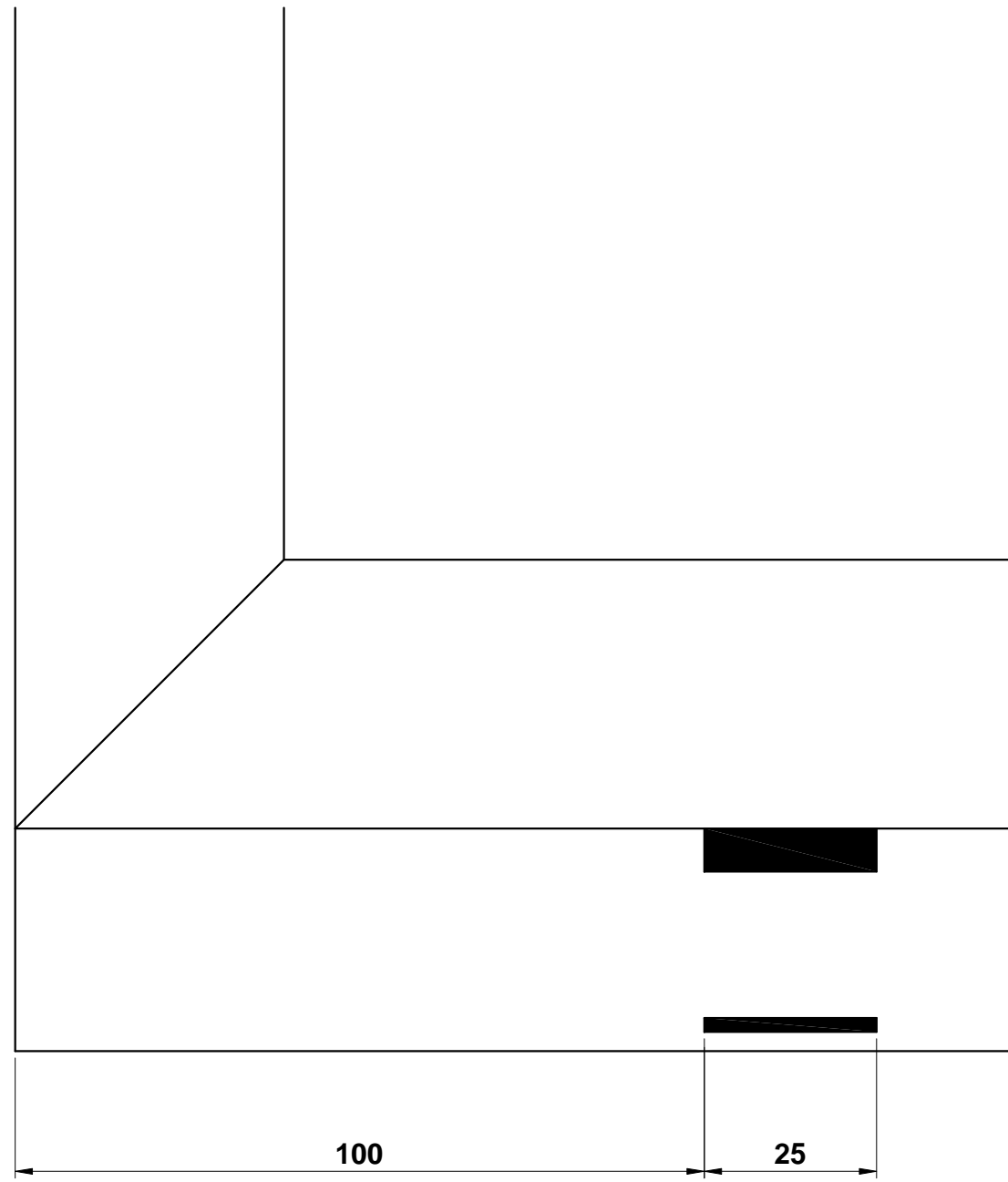


**Important Note:** All exposed aluminium should be coated using ACSIL014 or painted to match the frame.

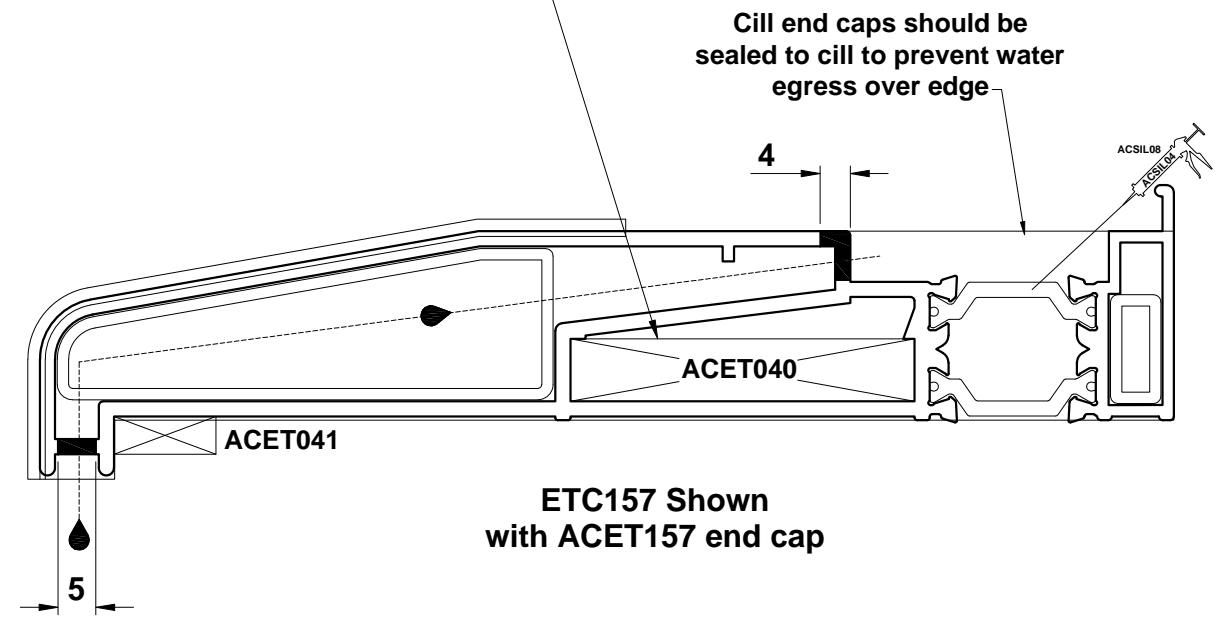


Do Not Scale From This Drawing

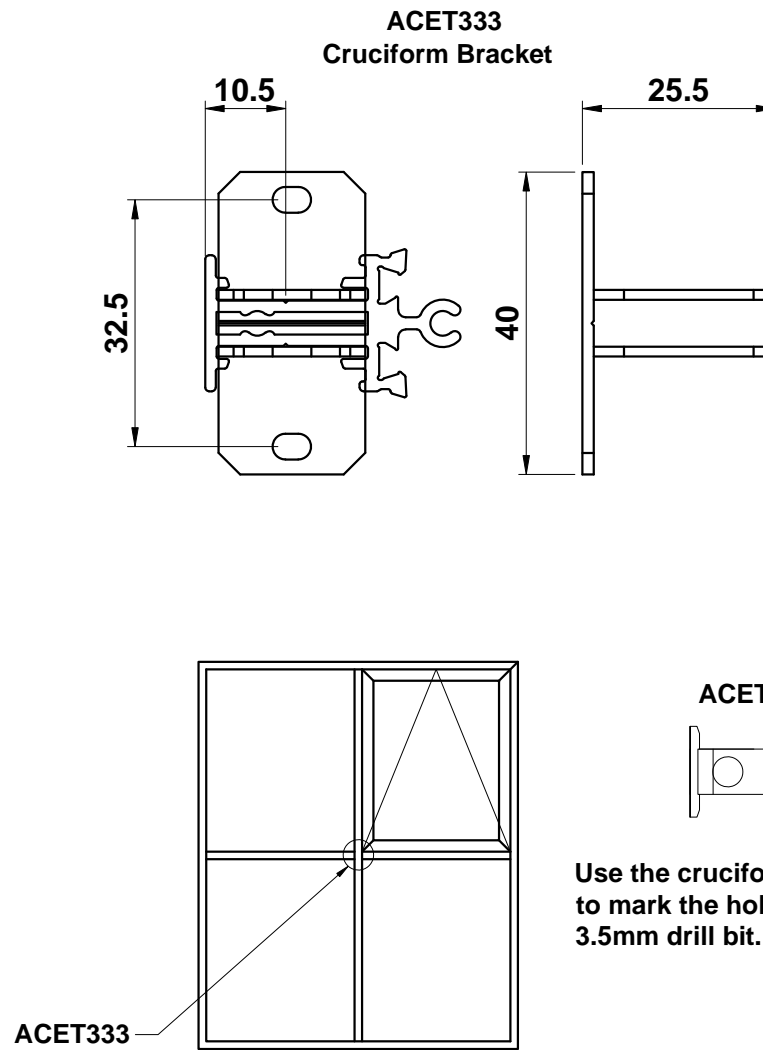
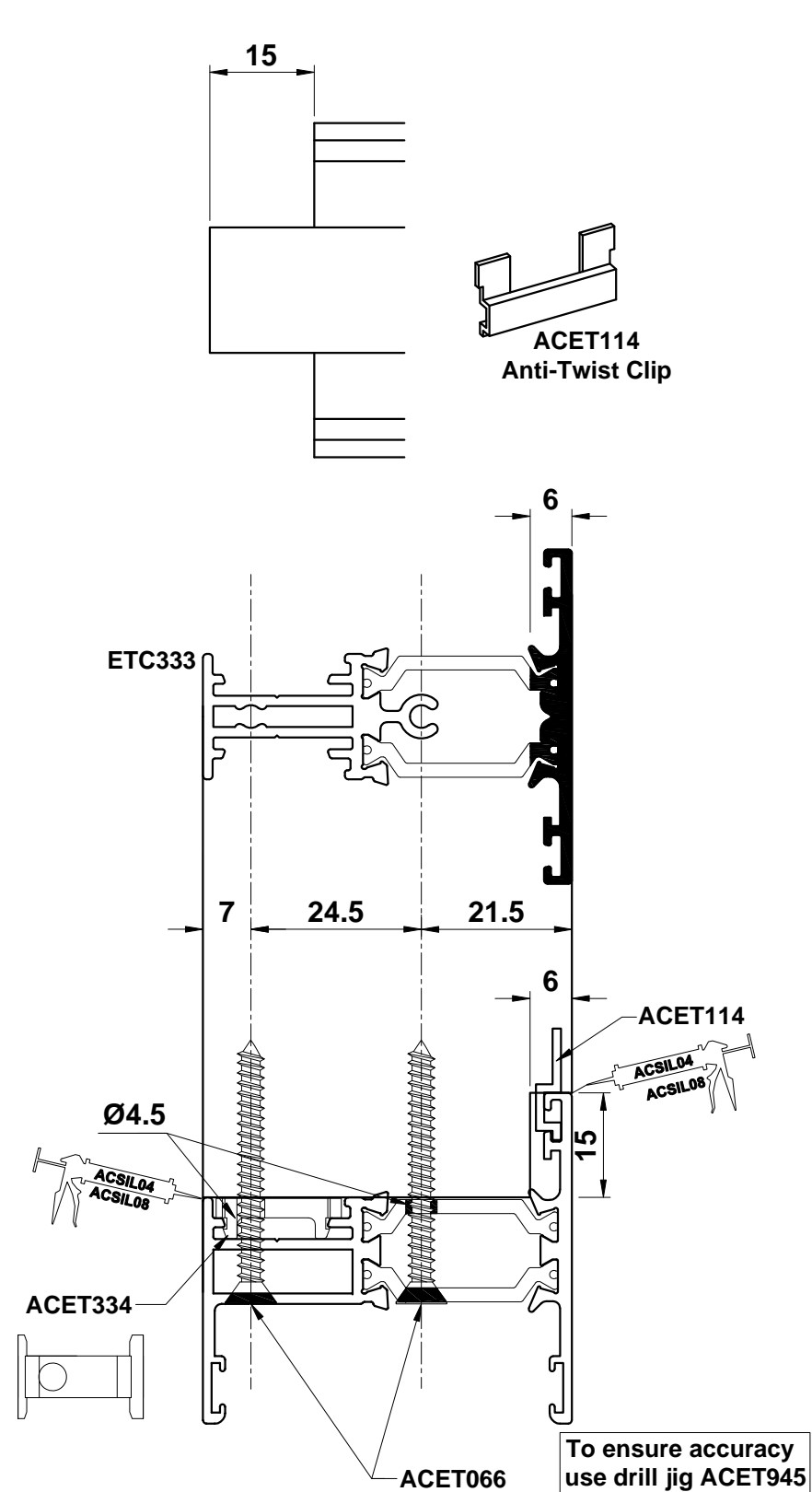




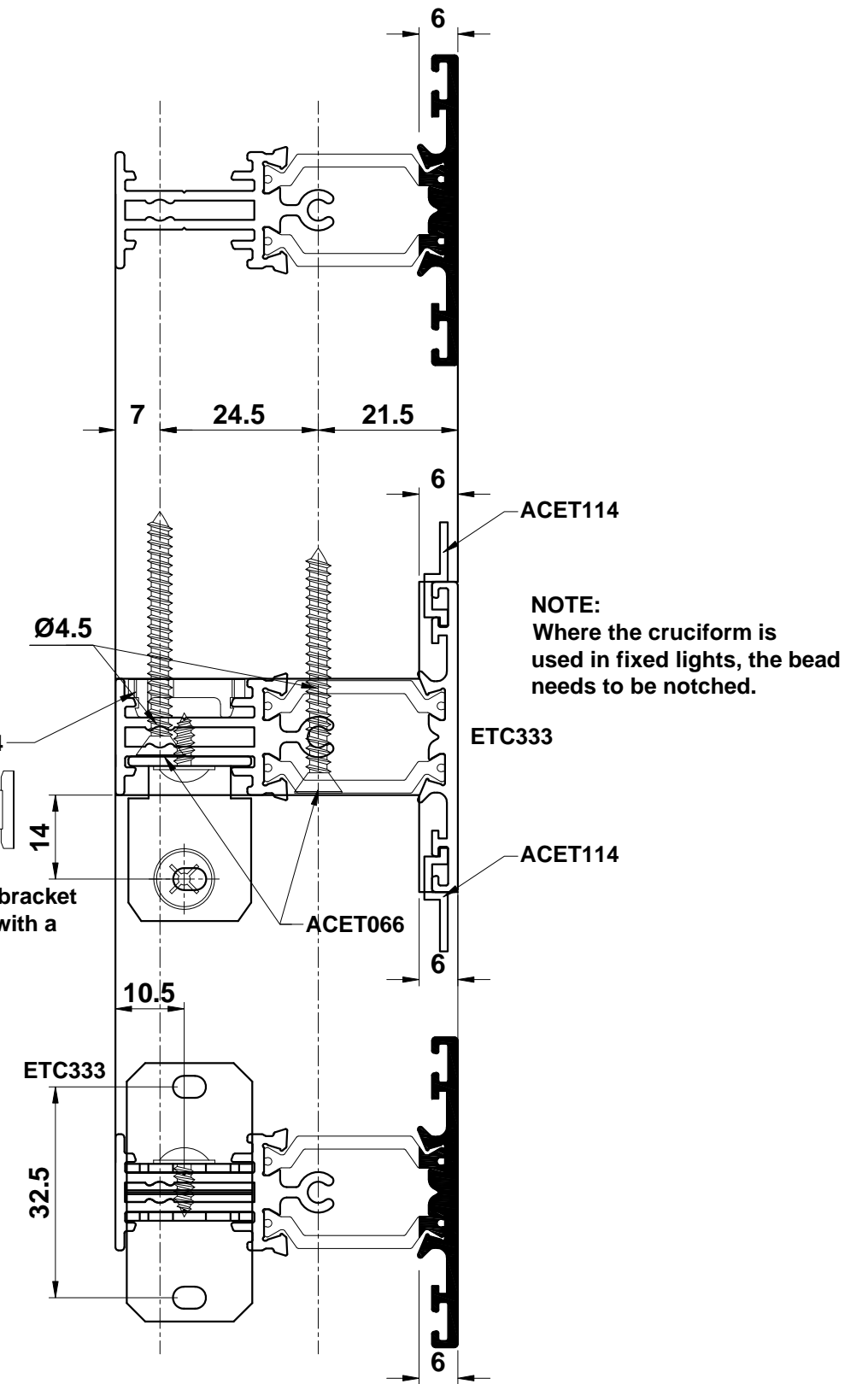
Drainage on Subcill



Do Not Scale From This Drawing



Use the cruciform bracket to mark the holes with a 3.5mm drill bit.

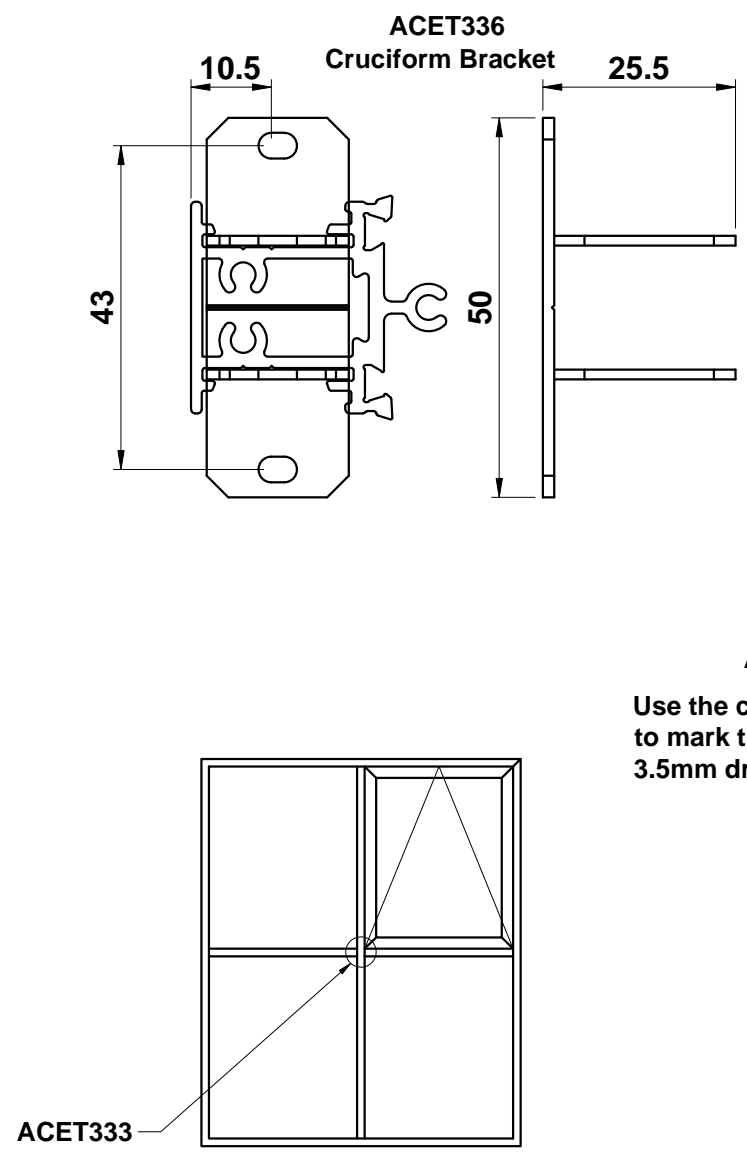
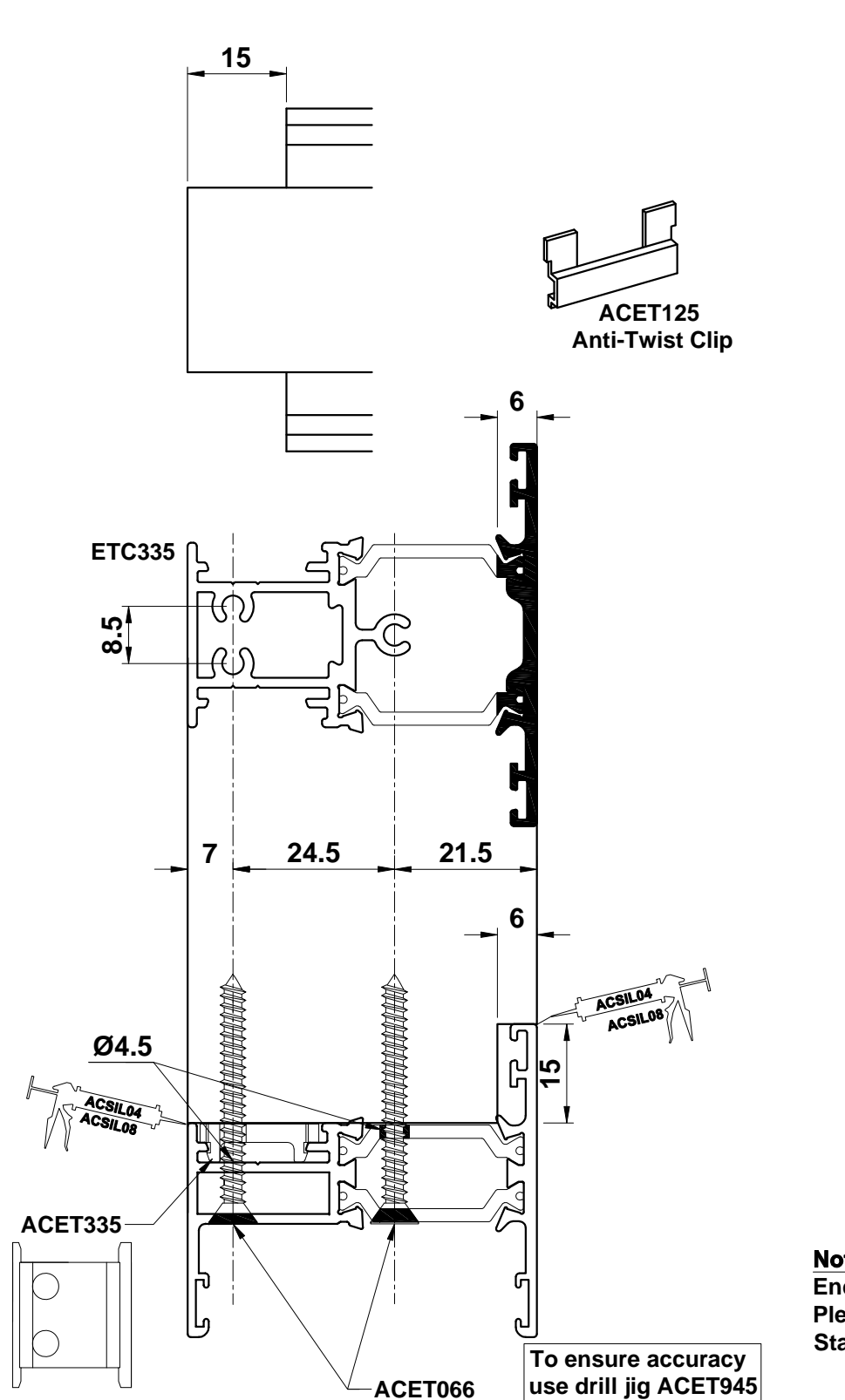


**Note:**  
End mill cutters can be ordered through Smart Systems Ltd.  
Please contact the Technical Department for an order form.  
Standard delivery is 2-3 weeks approx.

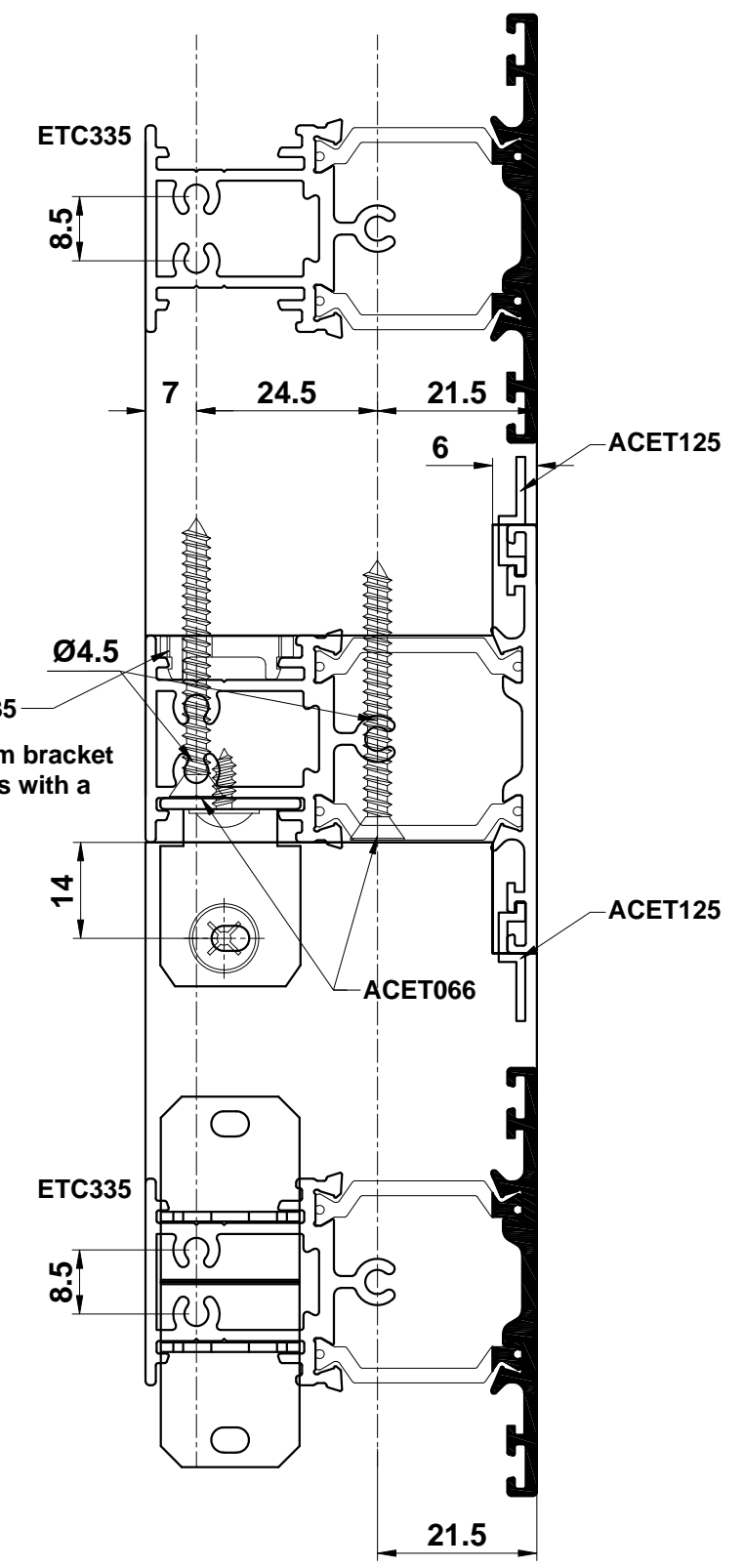
Do Not Scale From This Drawing

Transom/Mullion Preparation

Standard Stays



Use the cruciform bracket to mark the holes with a 3.5mm drill bit.



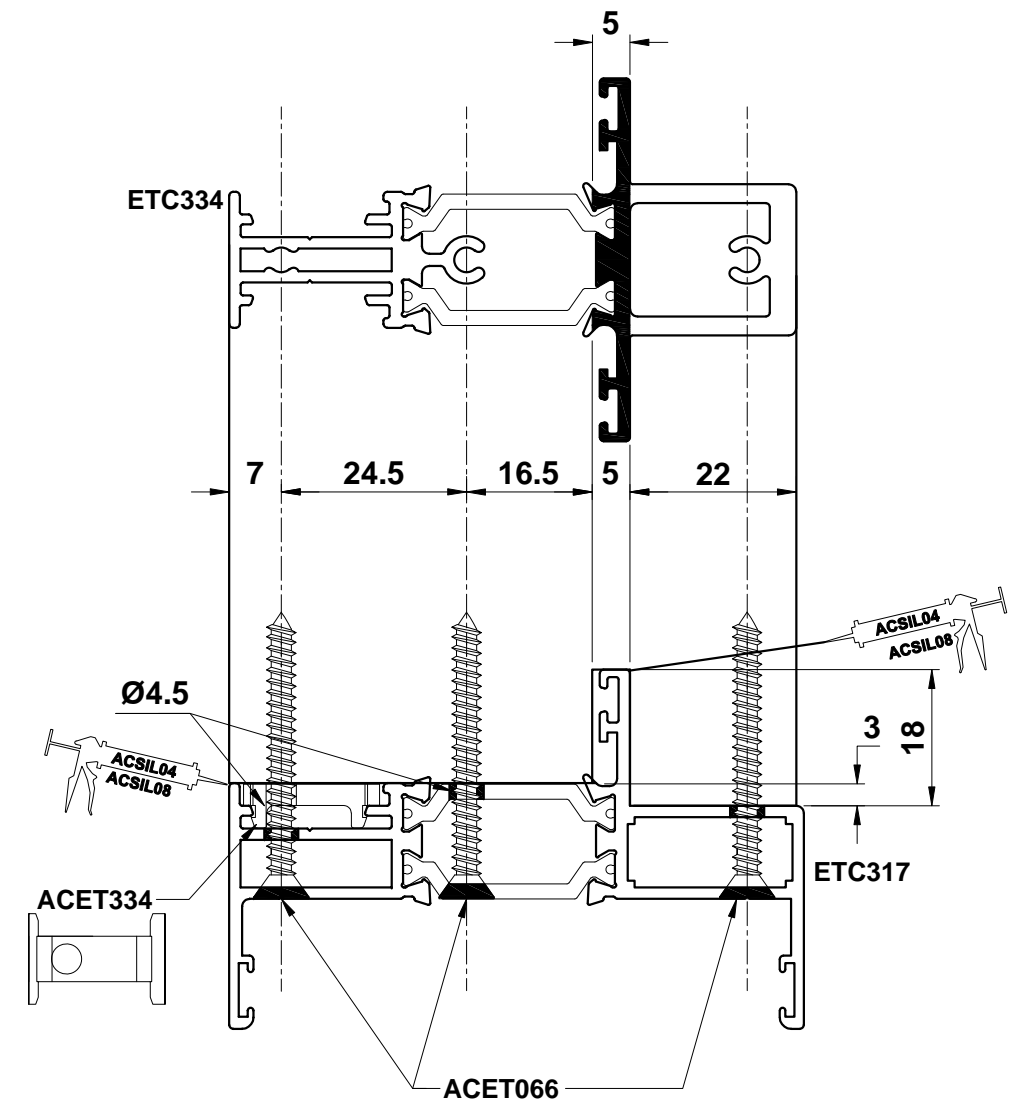
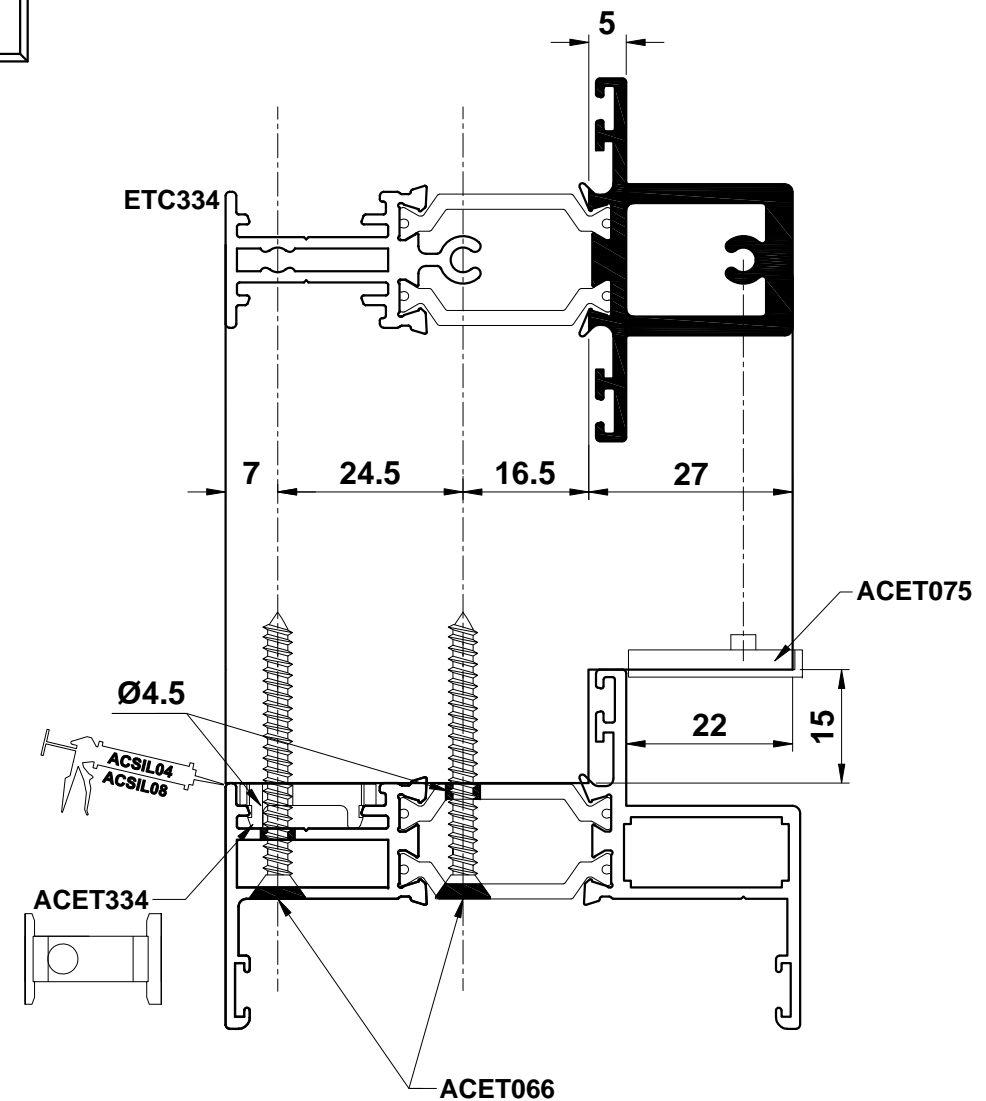
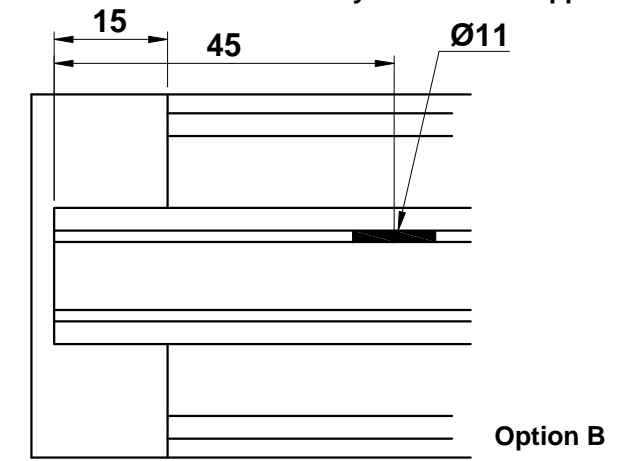
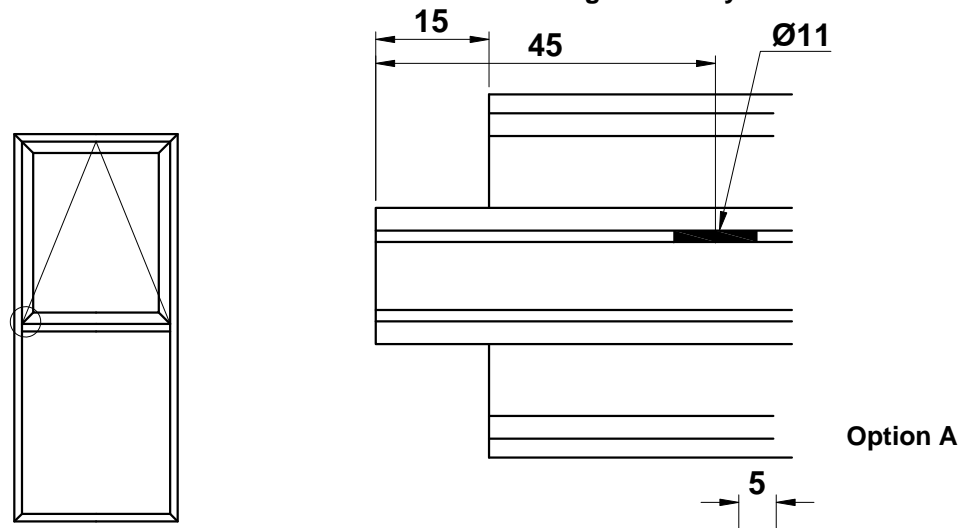
**Note:**  
End mill cutters can be ordered through Smart Systems Ltd.  
Please contact the Technical Department for an order form.  
Standard delivery is 2-3 weeks approx.

Do Not Scale From This Drawing

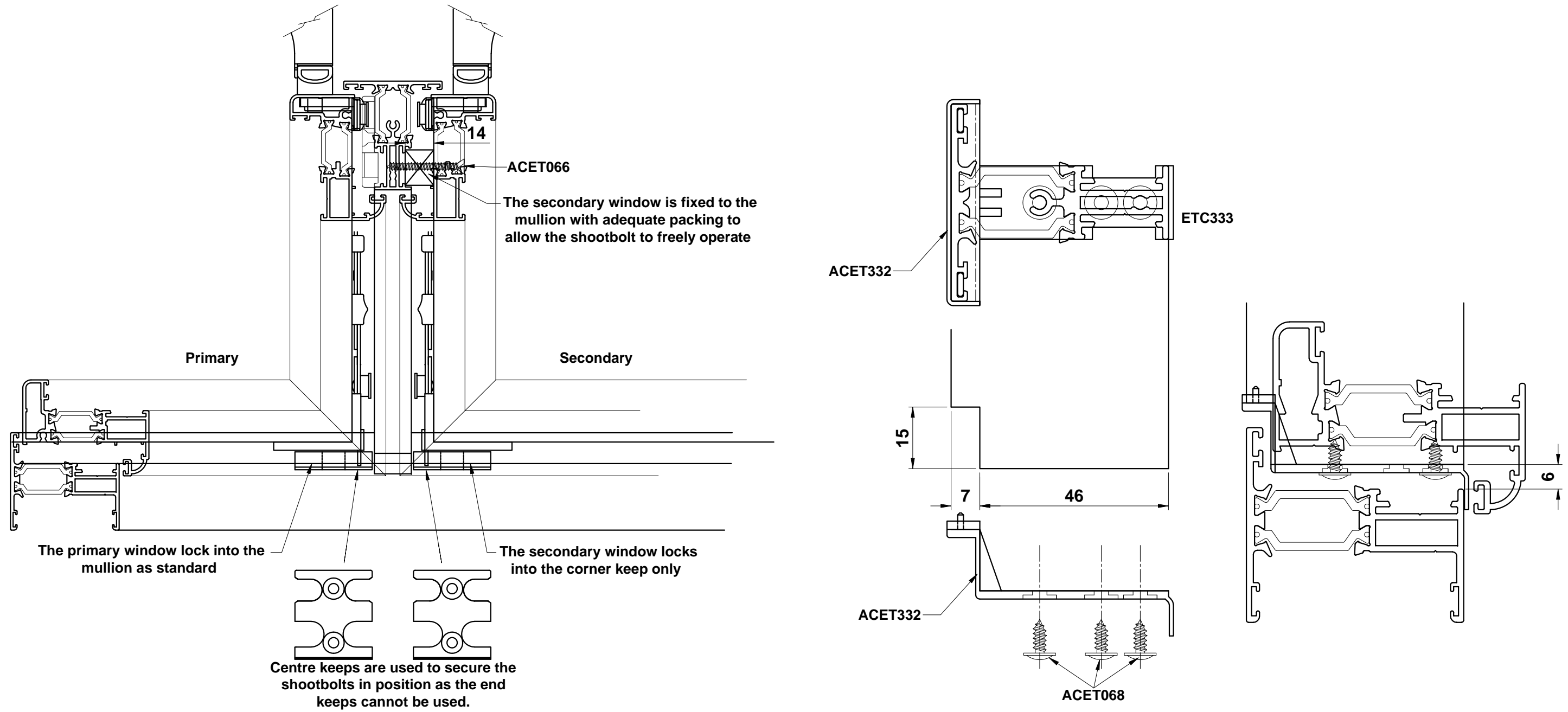
Transom/Mullion Preparation

Standard Stays

**Note:**  
End mill cutters can be ordered through Smart Systems Ltd. Please contact the Technical Department for an order form. Standard delivery is 2-3 weeks approx.

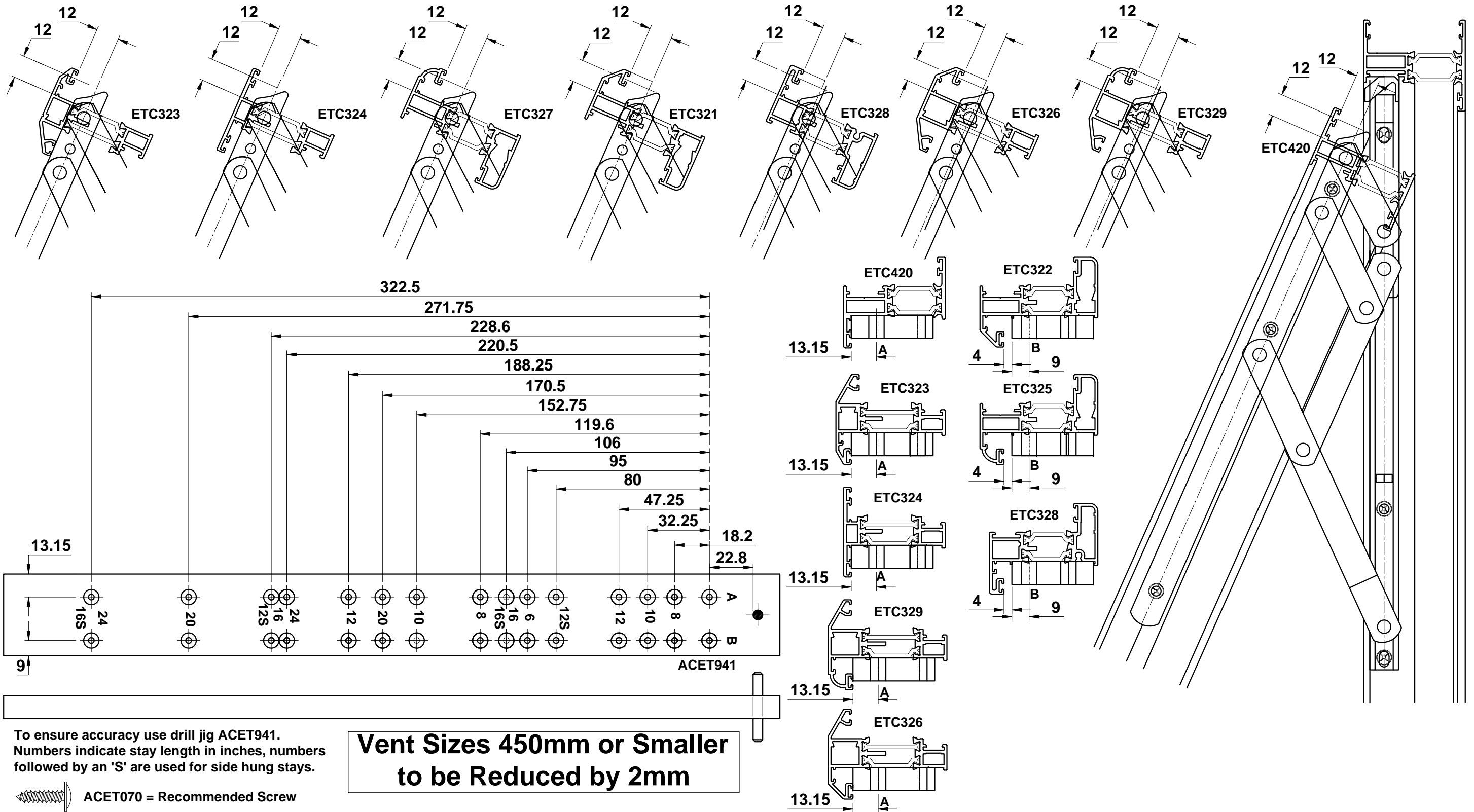


Do Not Scale From This Drawing




Do Not Scale From This Drawing

Standard Stays



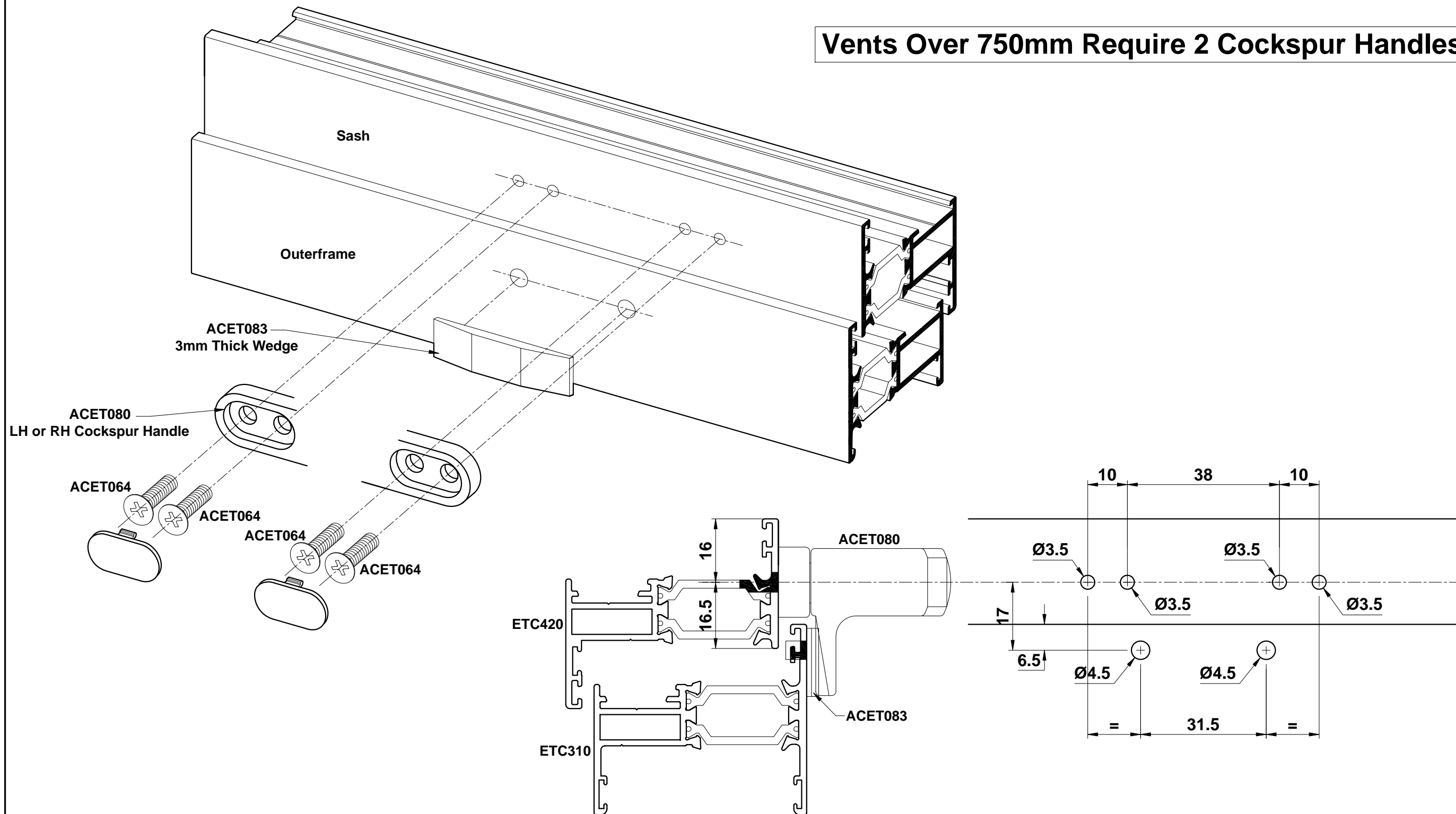
To ensure accuracy use drill jig ACET941.  
Numbers indicate stay length in inches, numbers followed by an 'S' are used for side hung stays.

**Vent Sizes 450mm or Smaller to be Reduced by 2mm**

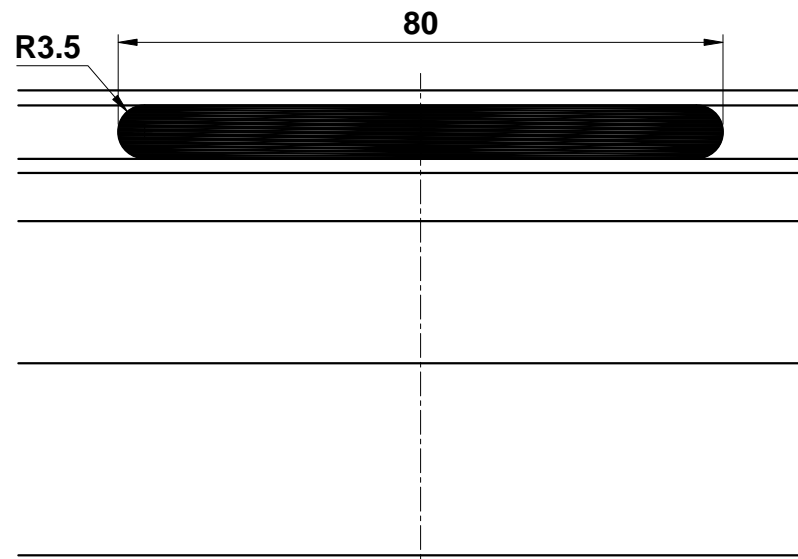
 ACET070 = Recommended Screw

Do Not Scale From This Drawing

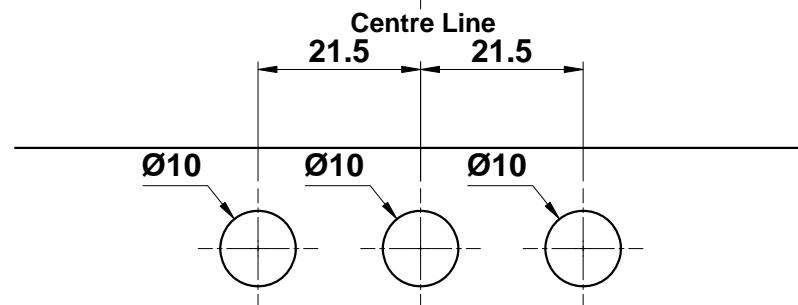
Vents Over 750mm Require 2 Cockspur Handles



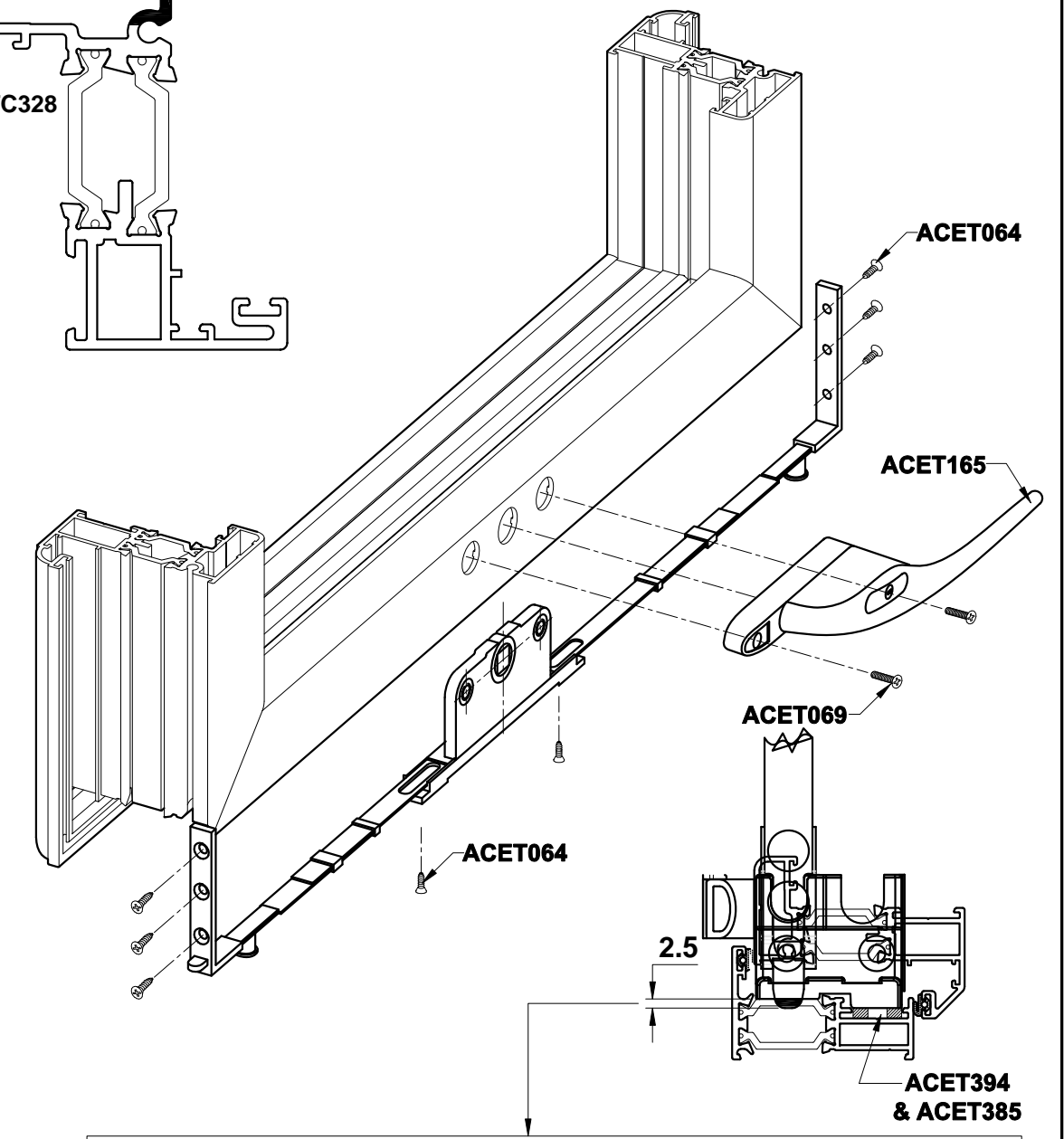
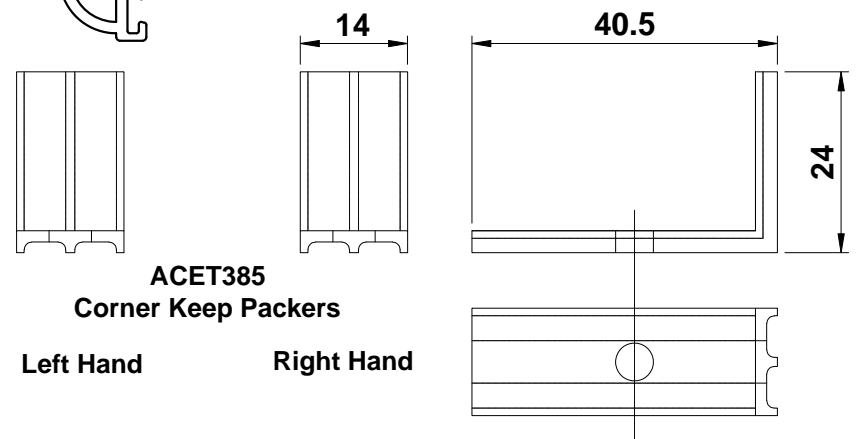
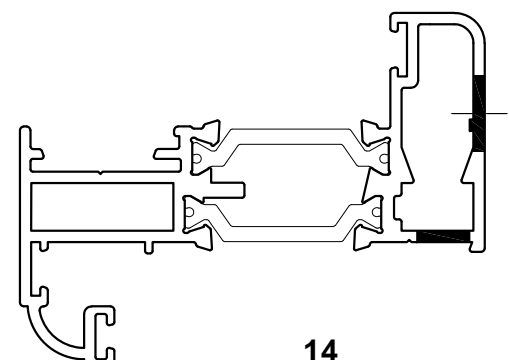
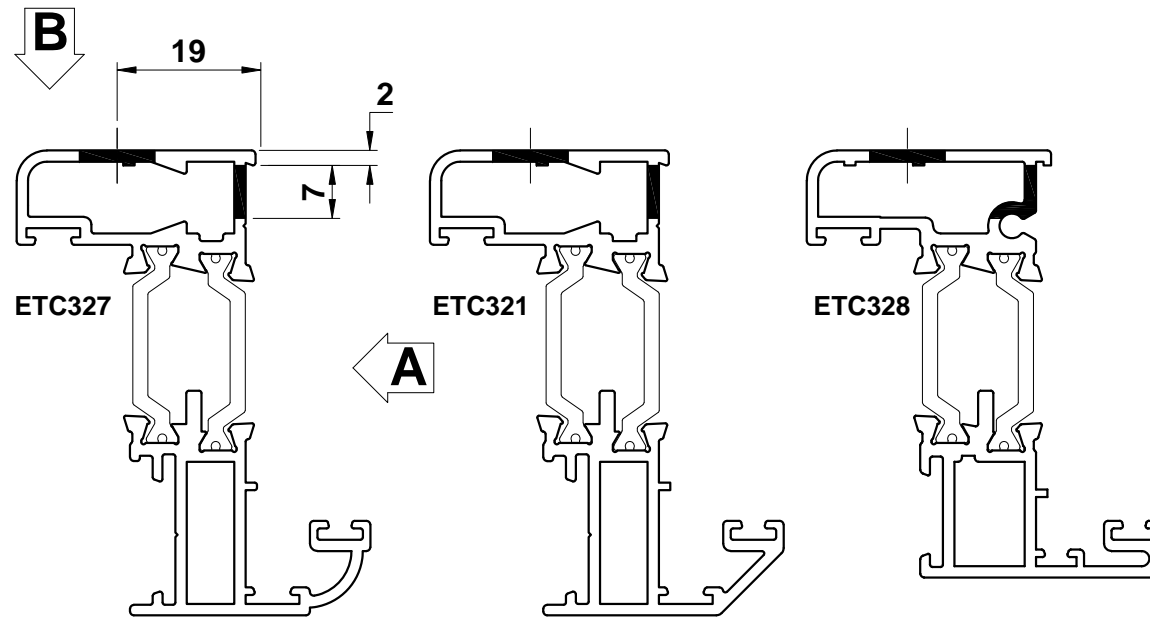
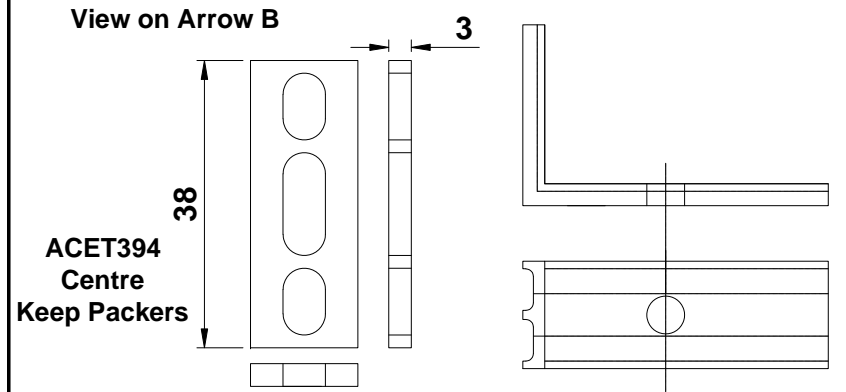
Do Not Scale From This Drawing



View on Arrow A



View on Arrow B



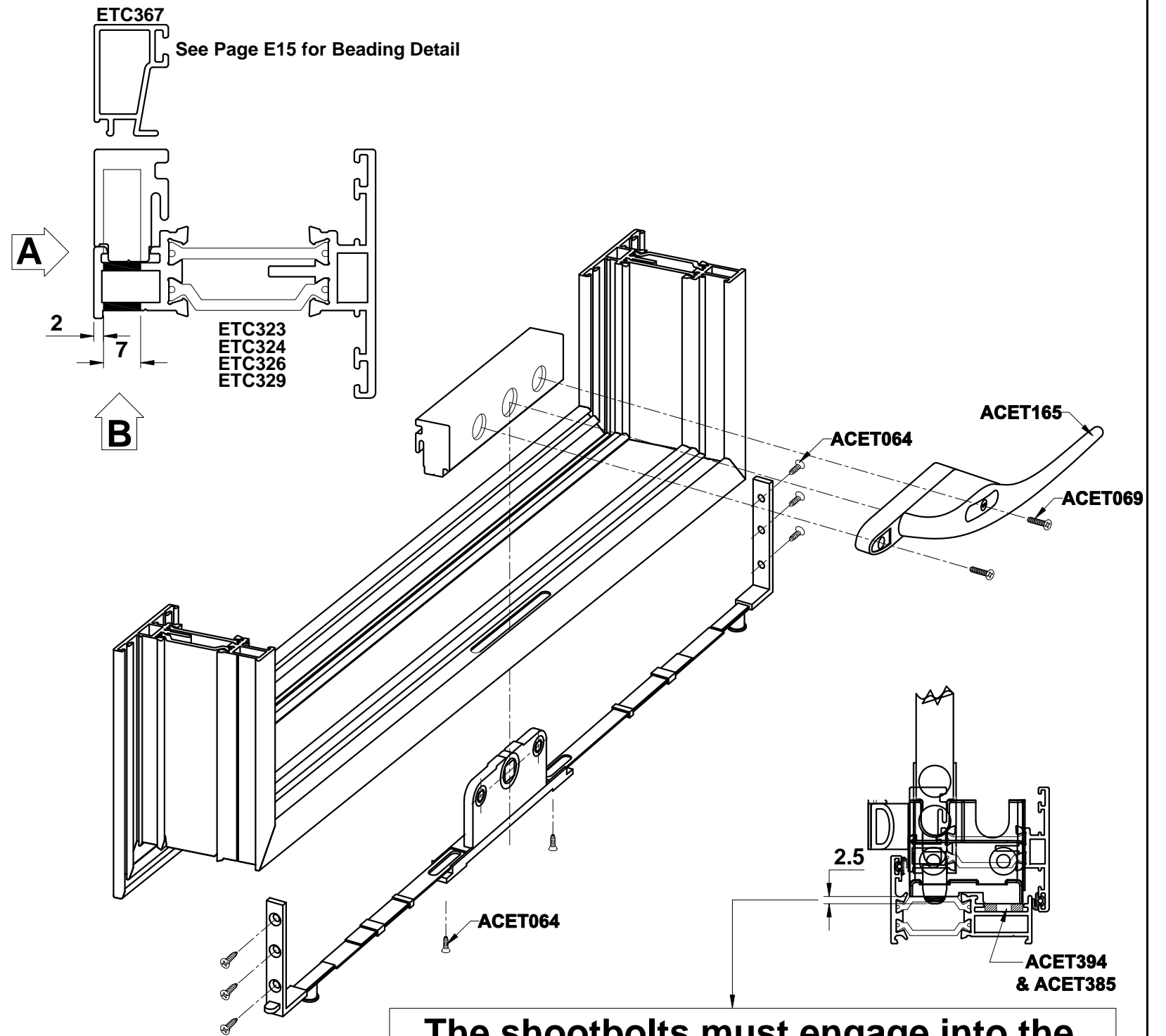
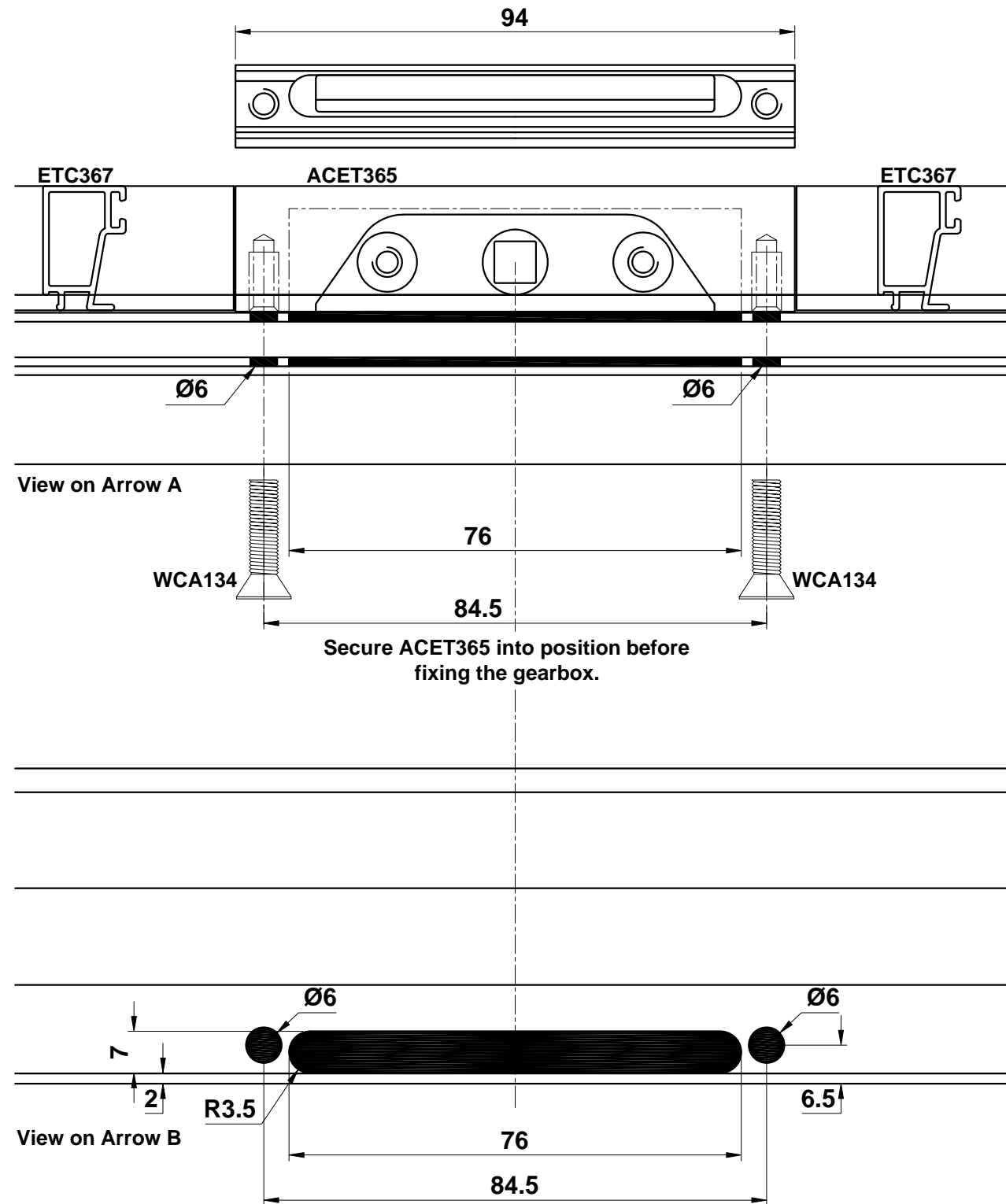
**The shootbolts must engage into the polyamide to ensure secure locking**

Do Not Scale From This Drawing



Multi-point Locking Preparation

Standard Stays



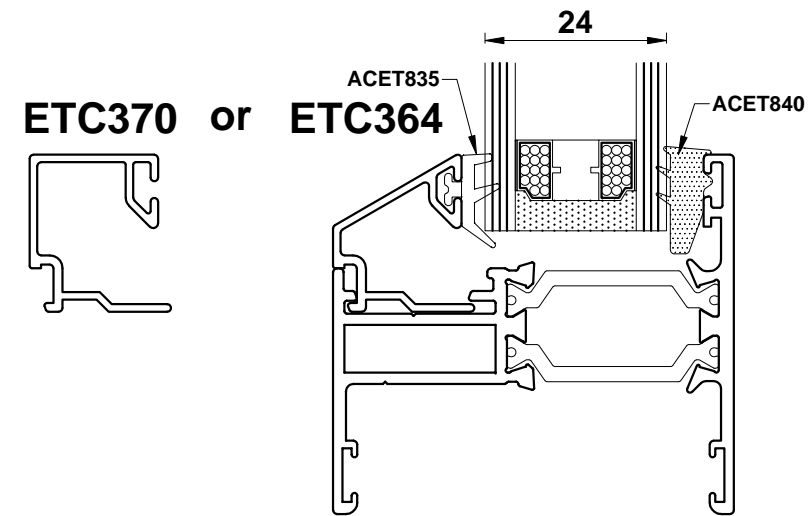
**The shootbolts must engage into the polyamide to ensure secure locking**

**See page E13 for keep packer information.**

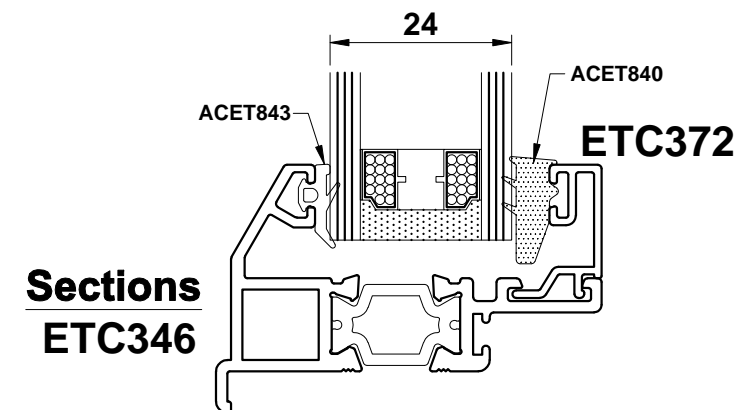
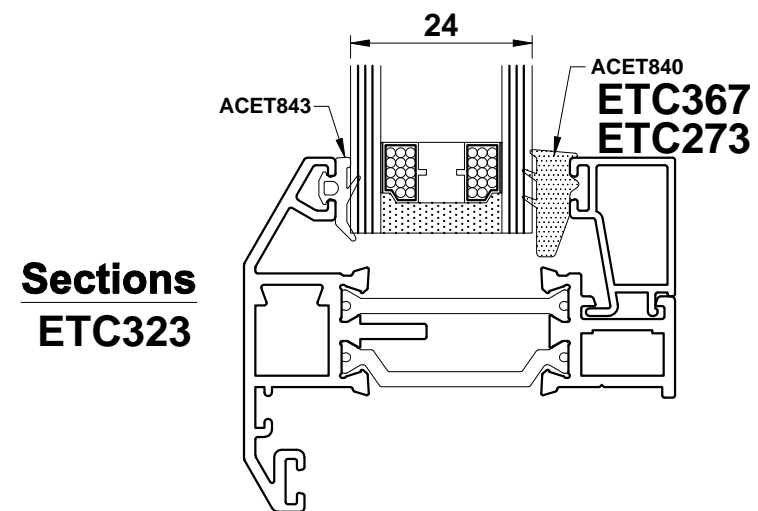
Do Not Scale From This Drawing

**24mm Glazing  
Externally Glazed**

- Sections**
- ETC307 ETC420 ETC333
  - ETC308 ETC321 ETC334
  - ETC309 ETC327 ETC335
  - ETC310
  - ETC313
  - ETC316
  - ETC317



**24mm Glazing  
Internally Glazed**



Do Not Scale From This Drawing

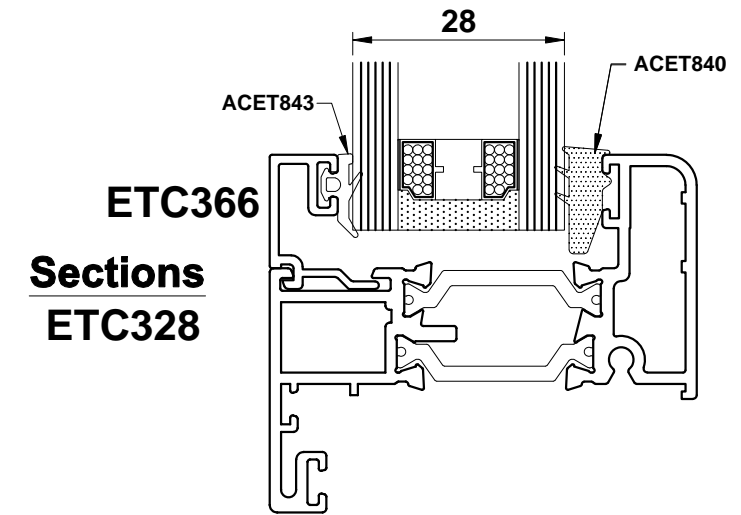
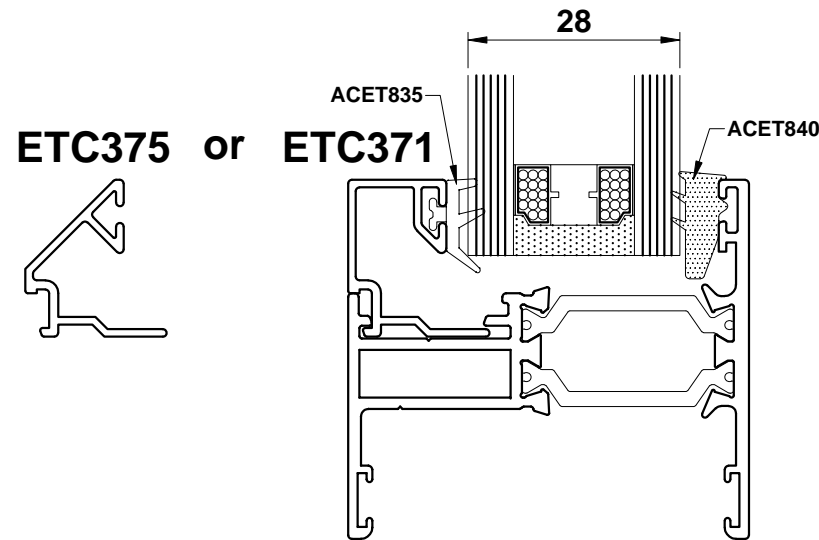
Glazing Details

Standard Stays

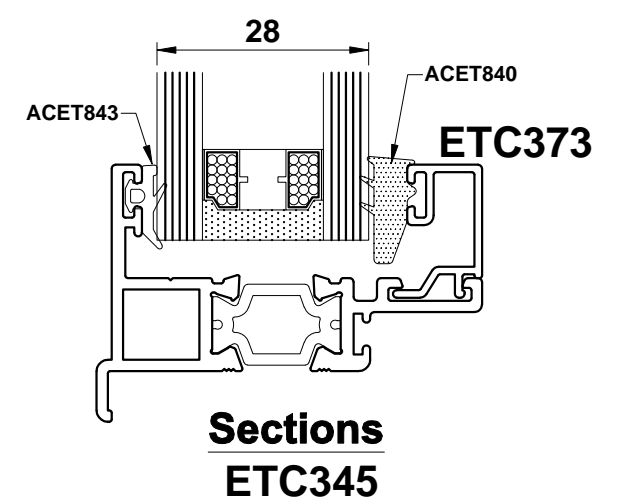
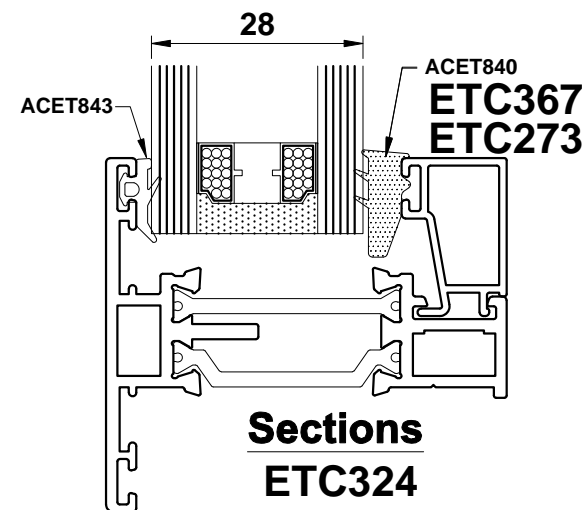
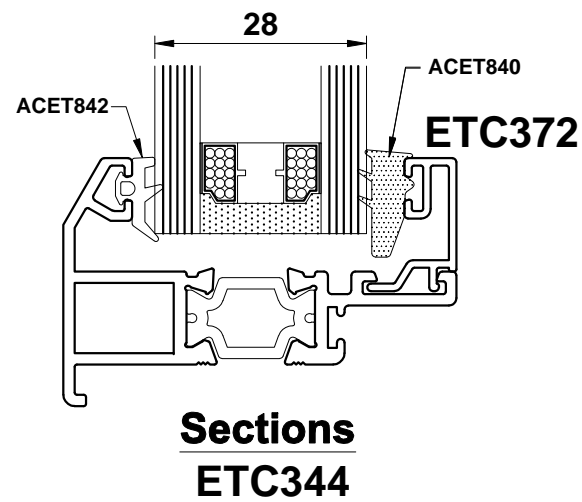
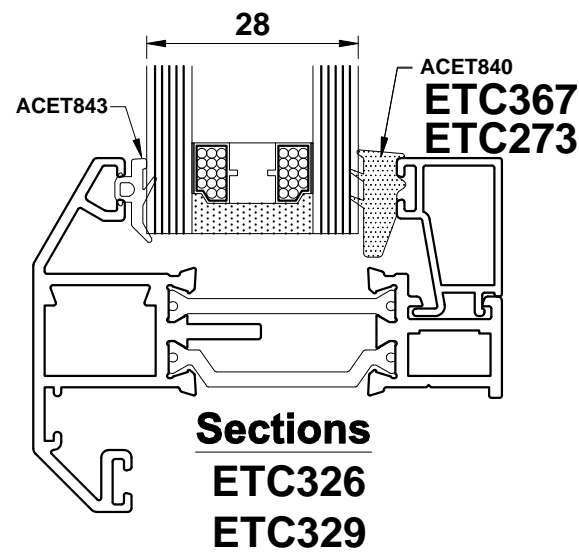
**28mm Glazing  
Externally Glazed**

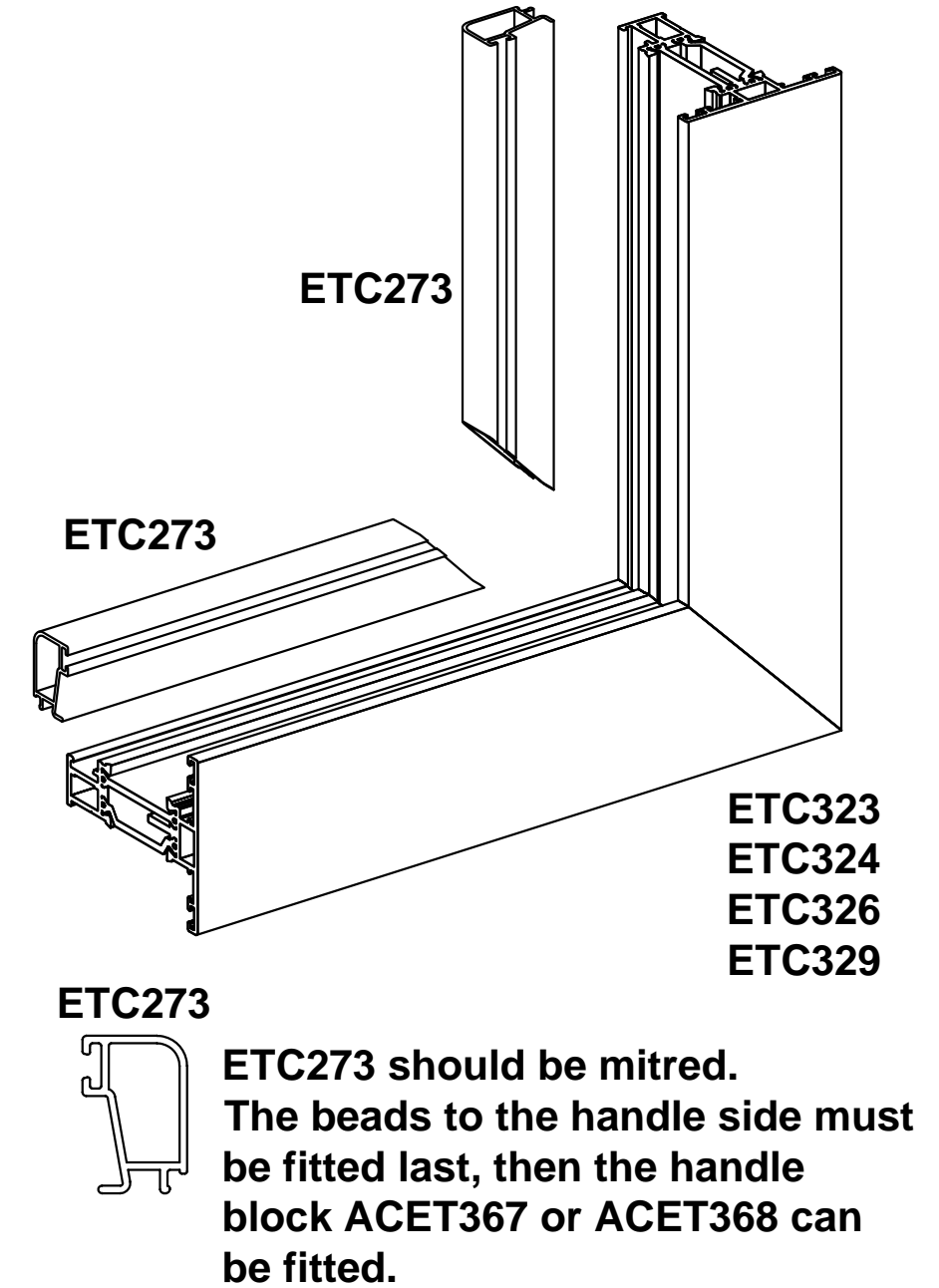
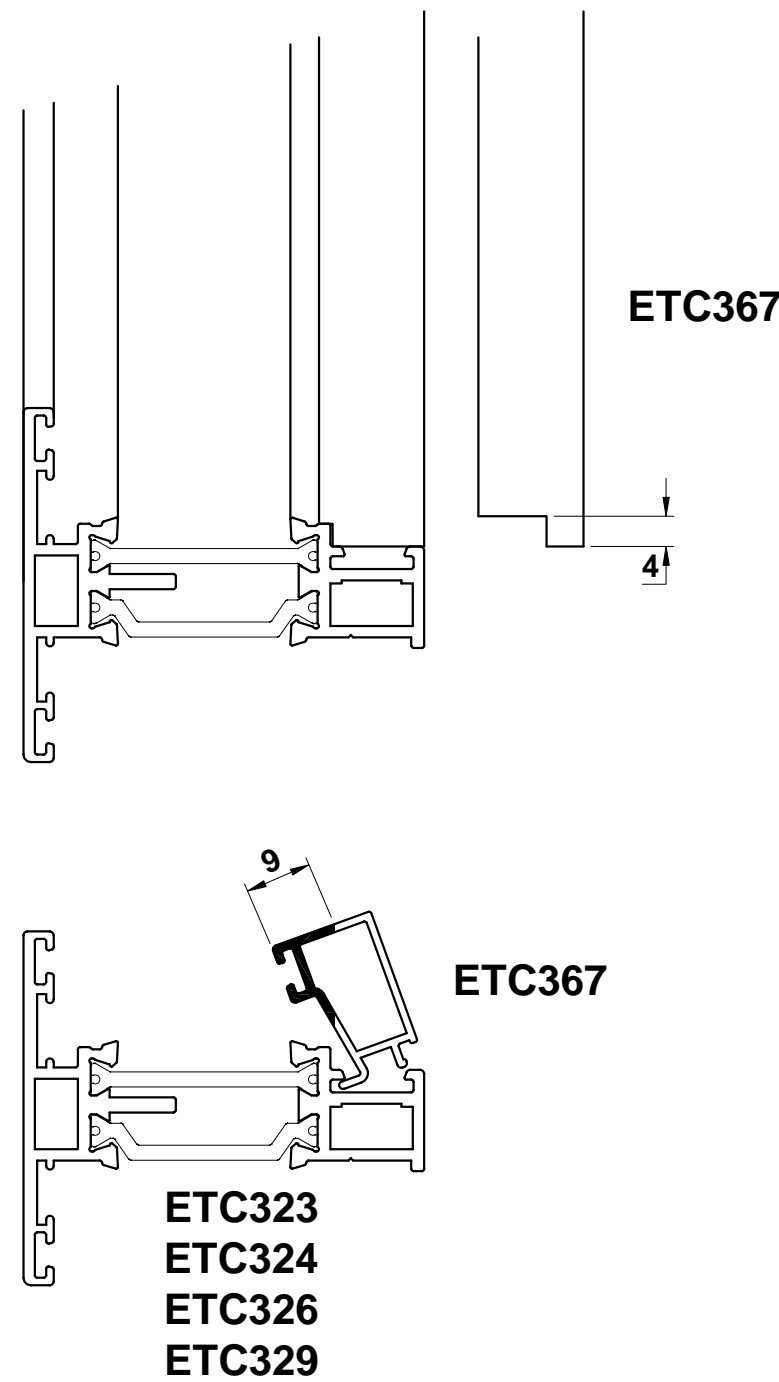
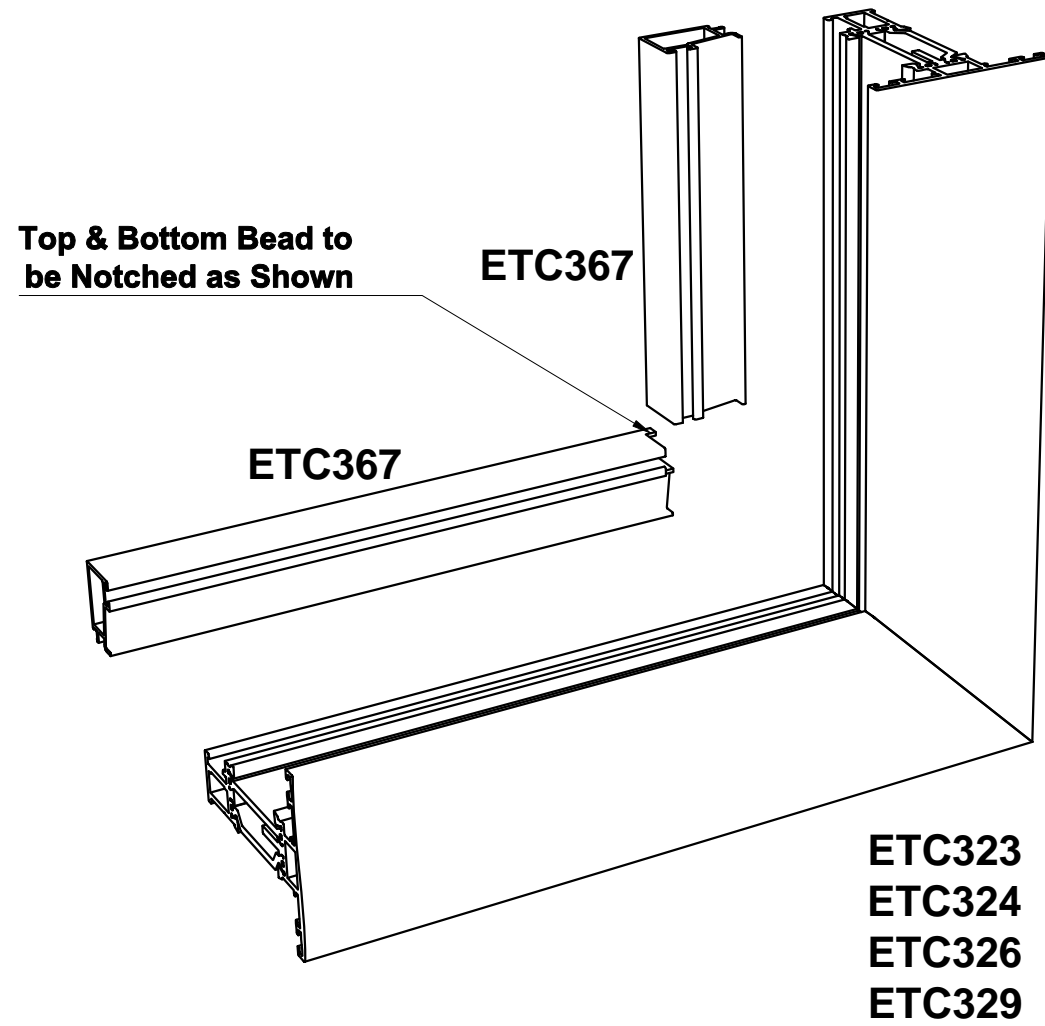
**Sections**

- ETC307 ETC420 ETC333
- ETC308 ETC321 ETC334
- ETC309 ETC327 ETC335
- ETC310
- ETC313
- ETC316
- ETC317

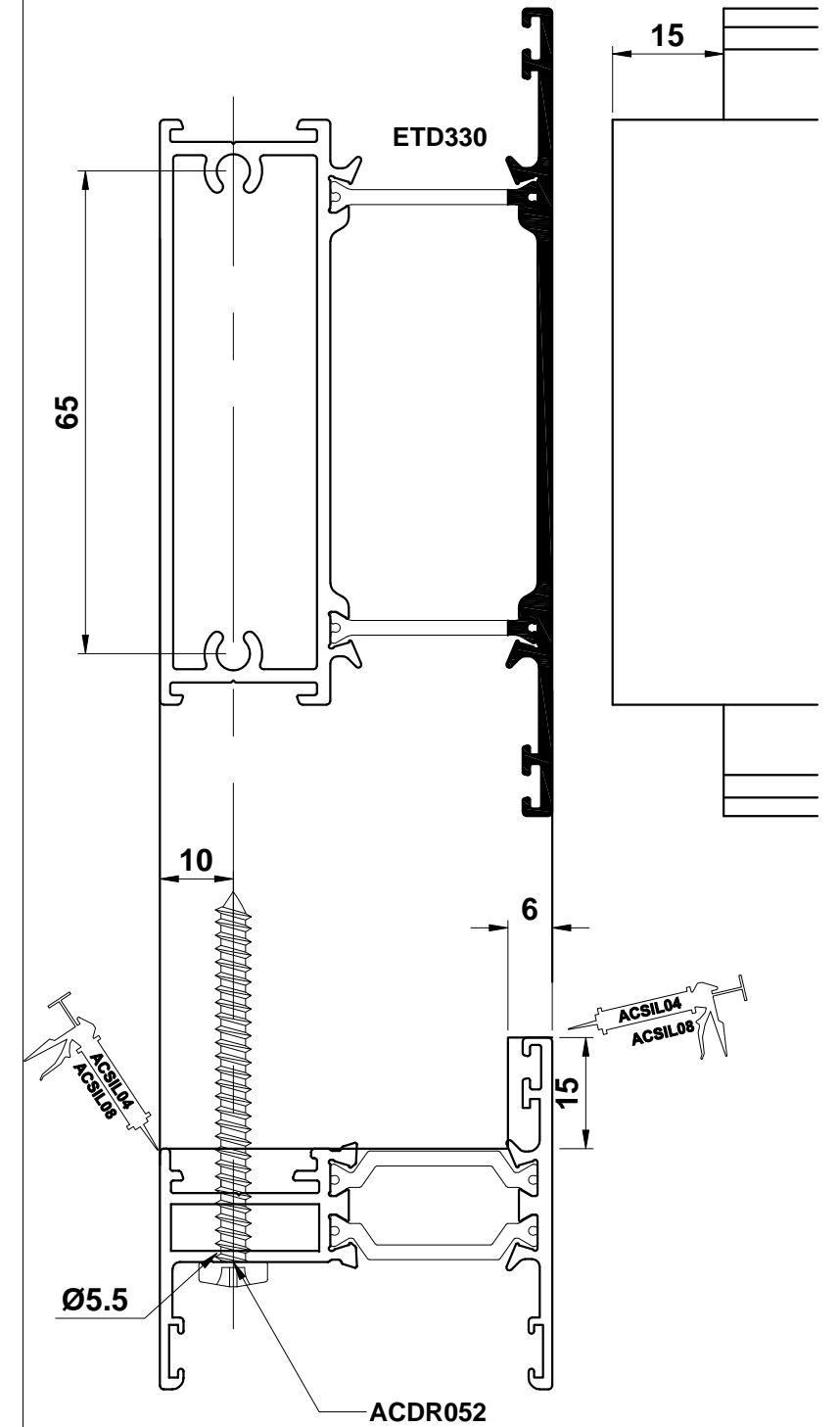
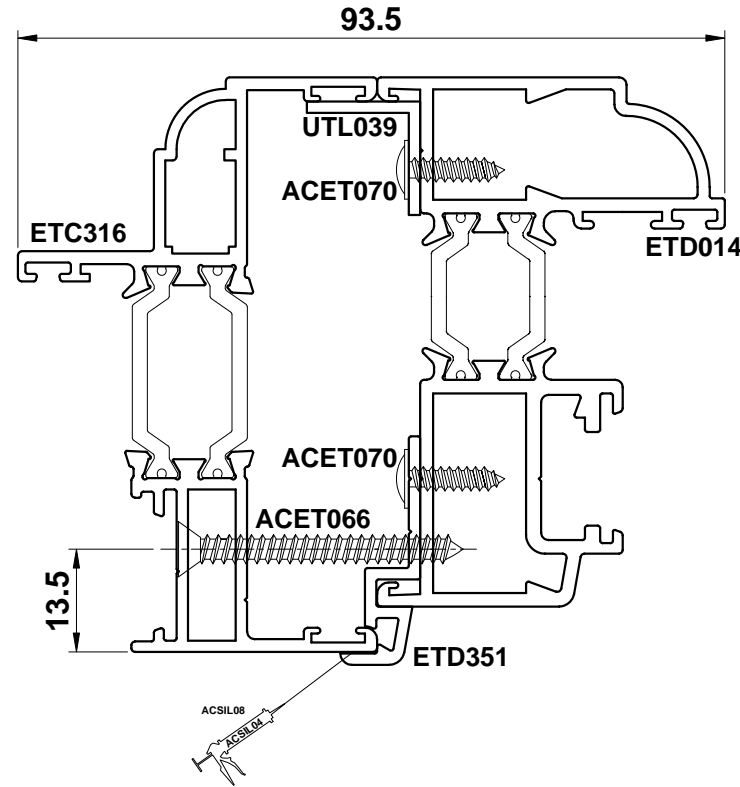
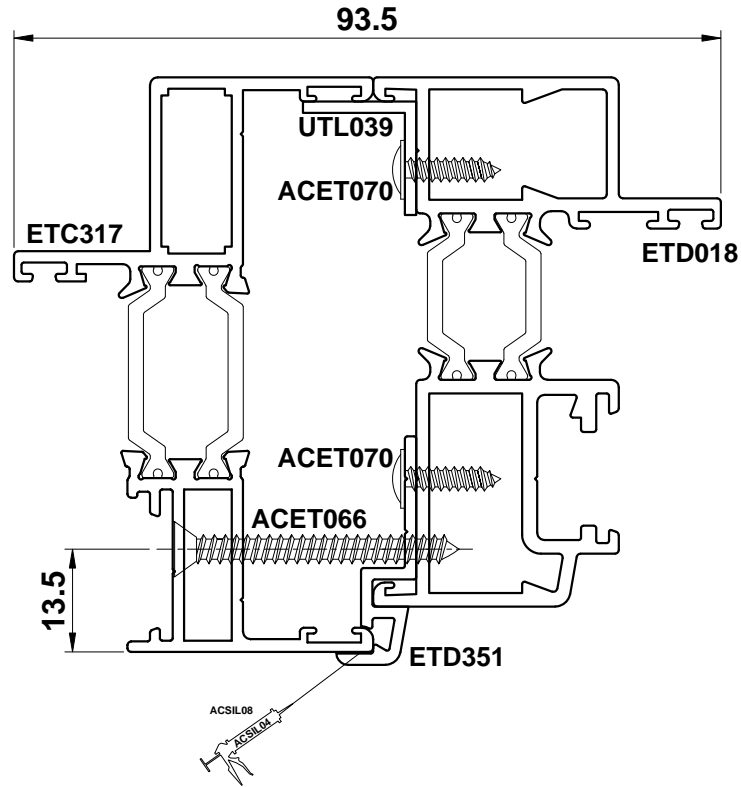
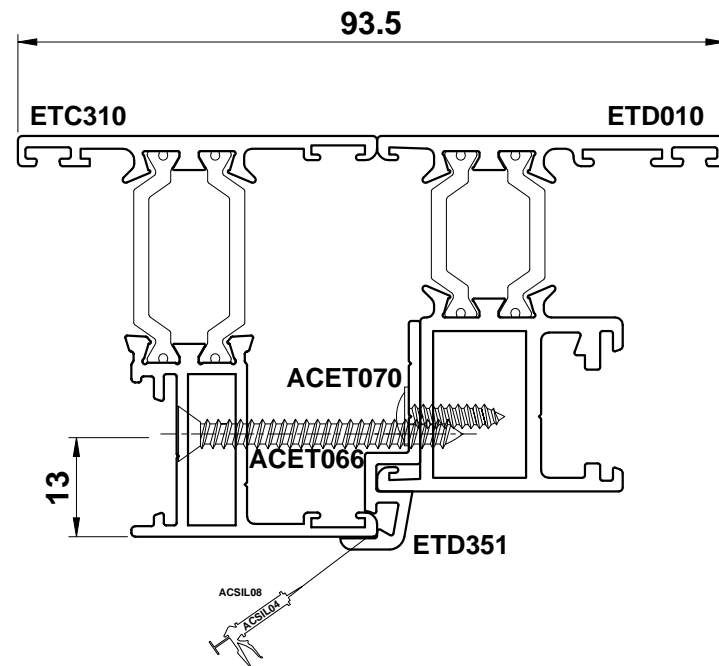
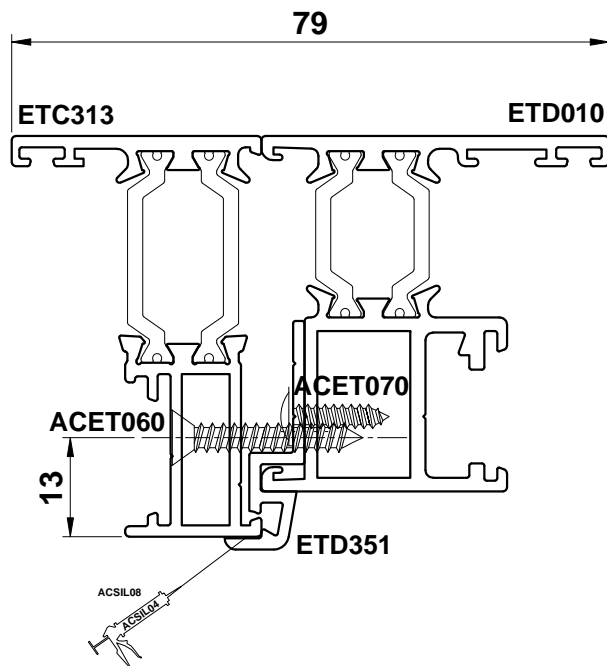
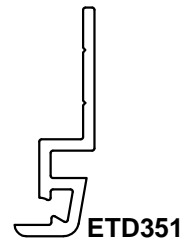
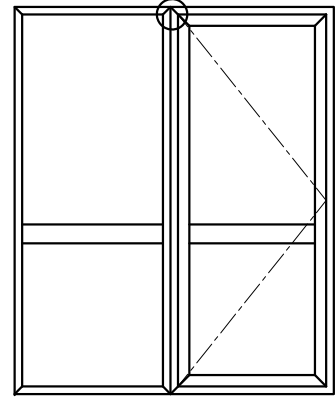


**28mm Glazing  
Internally Glazed**



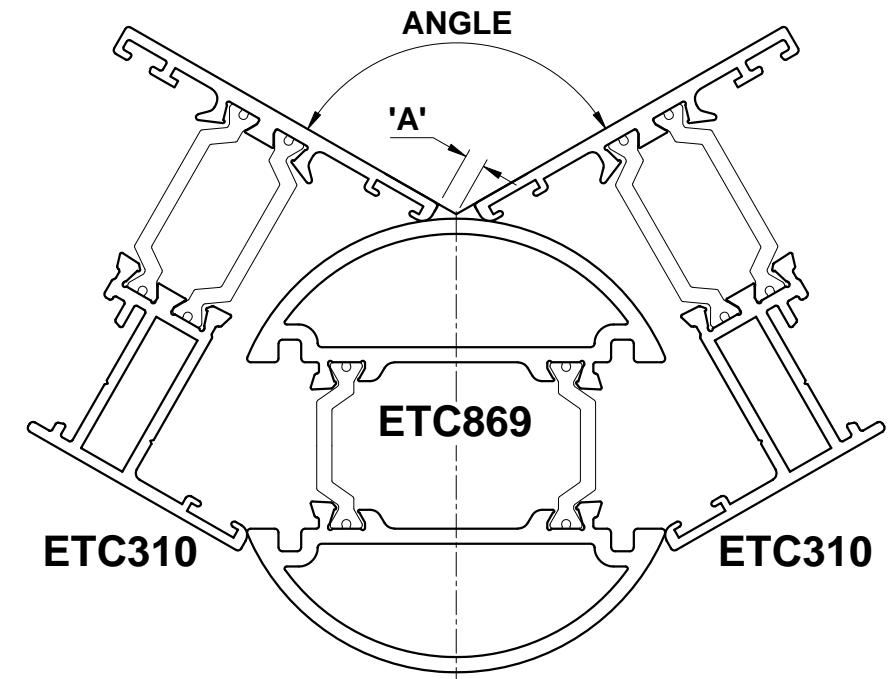
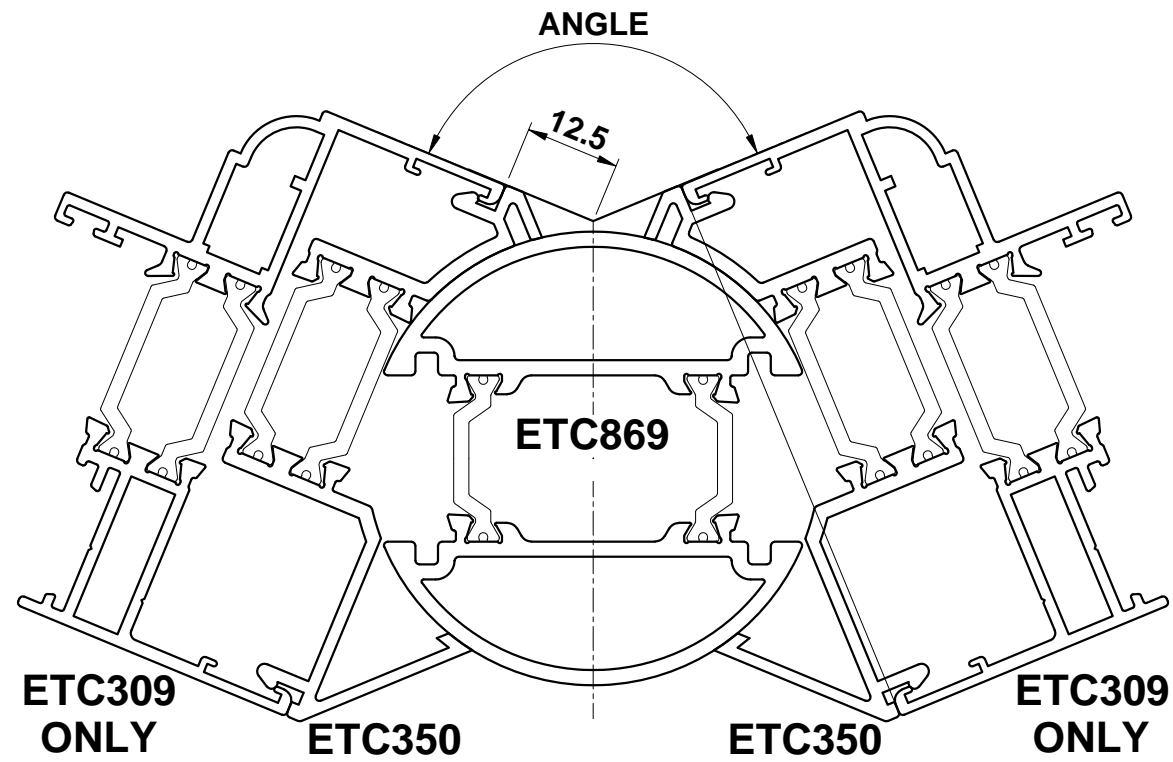


Do Not Scale From This Drawing



ETD330 can be used with a standard stay outframe providing the following beads are used in the midrail:  
 24mm = ETC362 with ACET841 externally & ACW20034 internally  
 28mm = ETC361 with ACET841 externally & ACW20034 internally

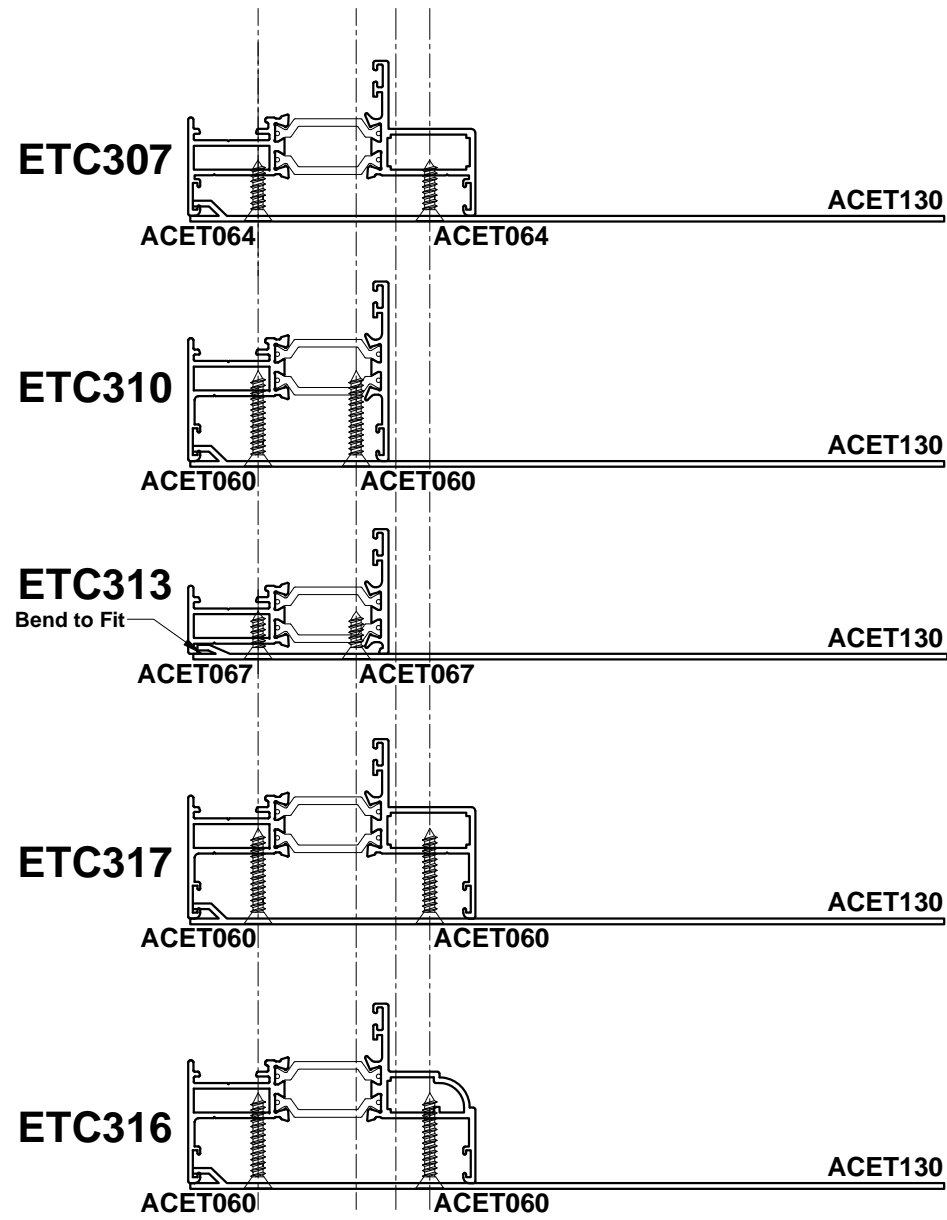
Do Not Scale From This Drawing



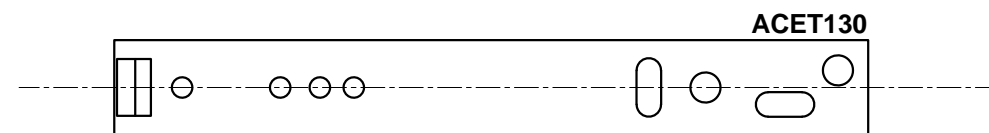
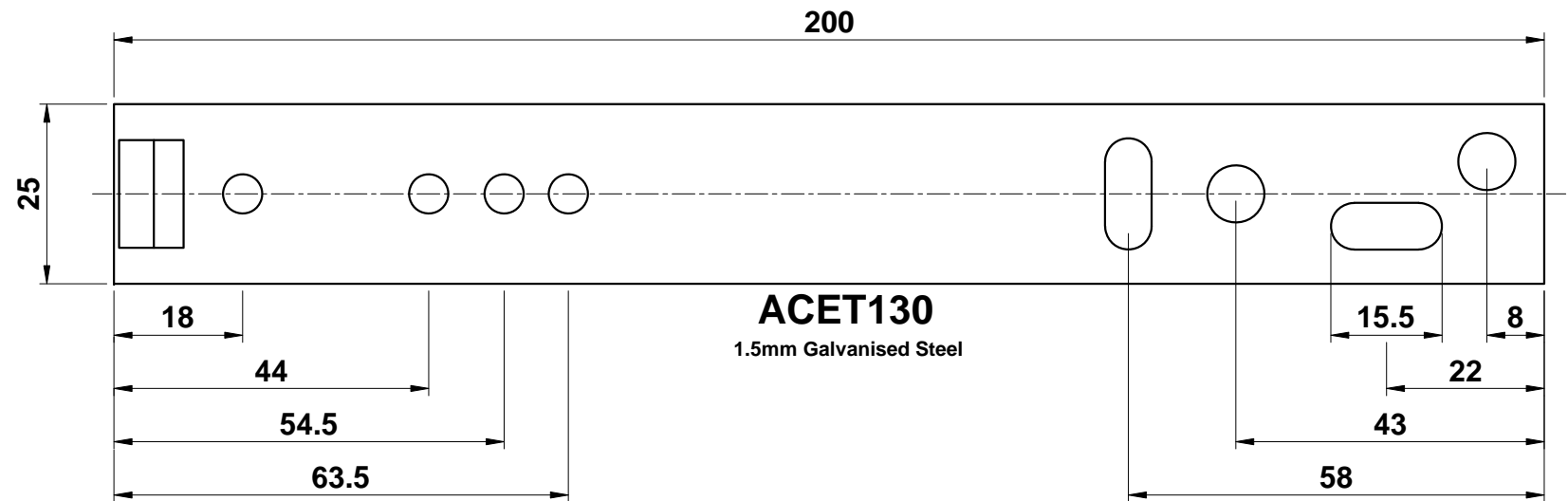
ANGLE	DEDUCTION 'A'
180°	24.5
175°	23
170°	22
165°	20.5
160°	19.5
155°	18
150°	17
145°	15.5
140°	14
135°	12.5
130°	11
125°	9.5
120°	8
115°	6
110°	4

ANGLE	DEDUCTION 'A'
180°	18
175°	17
170°	15.5
165°	14.5
160°	13
155°	12
150°	10.5
145°	9
140°	8
135°	6.5
130°	5.5
125°	4
120°	2.5

Do Not Scale From This Drawing



**NOTE:**  
Fixing straps should be spaced a minimum of 150mm in from each end & at a maximum of 300mm apart.



Do Not Scale From This Drawing

Section F



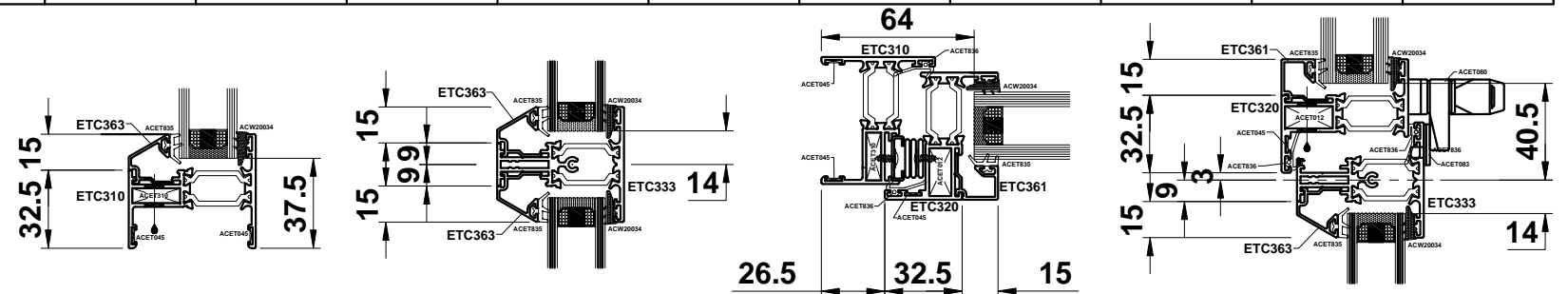
**Cutting Information - Standard Stays**

PART DESCRIPTIONS	TYPICAL STYLES	STYLES															
		①	①	①	①	①	①	①	①	①	①	①	①	①	①	①	
OUTER FRAME	HEAD & CILL	W	W	W	W	W	W	W	W	W	W	W	W	W	W	W	
	JAMBS	H	H	H	H	H	H	H	H	H	H	H	H	H	H	H	
	TRANSOM(S)		W - 65		W - 65	W - 65	W - 65		OF to $\mathcal{C}M$ - 41.5	W - 65		OF to $\mathcal{C}M$ - 41.5	$\mathcal{C}M$ to $\mathcal{C}M$ - 18	W - 65	OF to $\mathcal{C}M$ - 41.5	W - 65	
	MULLION(S)							H - 65	H - 65	OF to $\mathcal{C}T$ - 41.5	H - 65	H - 65	H - 65	OF to $\mathcal{C}T$ - 41.5	H - 65		
VENT (1)	HORIZONTAL COMPONENTS			W - 53	W - 53	W - 53	W - 53	OF to $\mathcal{C}M$ - 29.5	OF to $\mathcal{C}M$ - 29.5	OF to $\mathcal{C}M$ - 29.5	OF to $\mathcal{C}M$ - 29.5	OF to $\mathcal{C}M$ - 29.5	OF to $\mathcal{C}M$ - 29.5	OF to $\mathcal{C}M$ - 29.5	OF to $\mathcal{C}M$ - 29.5	W - 53	
	VERTICAL COMPONENTS			H - 53	OF to $\mathcal{C}T$ - 29.5	OF to $\mathcal{C}T$ - 29.5	$\mathcal{C}T$ to $\mathcal{C}T$ - 6	H - 53	H - 53	OF to $\mathcal{C}T$ - 29.5	H - 53	OF to $\mathcal{C}T$ - 29.5	H - 53	OF to $\mathcal{C}T$ - 29.5	OF to $\mathcal{C}T$ - 29.5	OF to $\mathcal{C}T$ - 29.5	
VENT (2)	HORIZONTAL COMPONENTS					W - 53			OF to $\mathcal{C}M$ - 29.5					$\mathcal{C}M$ to $\mathcal{C}M$ - 6	$\mathcal{C}M$ to $\mathcal{C}M$ - 6		
	VERTICAL COMPONENTS						OF to $\mathcal{C}T$ - 29.5		OF to $\mathcal{C}T$ - 29.5					OF to $\mathcal{C}T$ - 29.5	OF to $\mathcal{C}T$ - 29.5		
VENT (1)	GLASS WIDTH			W - 128	W - 128	W - 128	W - 128	OF to $\mathcal{C}M$ - 104.5	OF to $\mathcal{C}M$ - 104.5	OF to $\mathcal{C}M$ - 104.5	OF to $\mathcal{C}M$ - 104.5	OF to $\mathcal{C}M$ - 104.5	OF to $\mathcal{C}M$ - 104.5	OF to $\mathcal{C}M$ - 104.5	OF to $\mathcal{C}M$ - 104.5	W - 128	
	GLASS HEIGHT			H - 128	OF to $\mathcal{C}T$ - 104.5	OF to $\mathcal{C}T$ - 104.5	$\mathcal{C}T$ to $\mathcal{C}T$ - 104.5	H - 128	H - 128	OF to $\mathcal{C}T$ - 104.5	H - 128	OF to $\mathcal{C}T$ - 104.5	H - 128	OF to $\mathcal{C}T$ - 104.5	OF to $\mathcal{C}T$ - 104.5	OF to $\mathcal{C}T$ - 104.5	
VENT (2)	GLASS WIDTH								OF to $\mathcal{C}M$ - 104.5					$\mathcal{C}M$ to $\mathcal{C}M$ - 81	$\mathcal{C}M$ to $\mathcal{C}M$ - 81		
	GLASS HEIGHT								OF to $\mathcal{C}T$ - 104.5					OF to $\mathcal{C}T$ - 104.5	OF to $\mathcal{C}T$ - 104.5		
FIXED PANEL (1)	GLASS WIDTH	W - 65	W - 65		W - 65		W - 65	OF to $\mathcal{C}M$ - 51.5	OF to $\mathcal{C}M$ - 51.5	W - 65	$\mathcal{C}M$ to $\mathcal{C}M$ - 28	$\mathcal{C}M$ to $\mathcal{C}M$ - 28	$\mathcal{C}M$ to $\mathcal{C}M$ - 28	W - 65	OF to $\mathcal{C}M$ - 51.5	W - 65	
	GLASS HEIGHT	H - 65	OF to $\mathcal{C}T$ - 51.5		OF to $\mathcal{C}T$ - 51.5		OF to $\mathcal{C}T$ - 51.5	H - 65	OF to $\mathcal{C}T$ - 51.5	OF to $\mathcal{C}T$ - 51.5	H - 65	H - 65	OF to $\mathcal{C}T$ - 51.5	OF to $\mathcal{C}T$ - 51.5	H - 65	OF to $\mathcal{C}T$ - 51.5	
FIXED PANEL (2)	GLASS WIDTH																
	GLASS HEIGHT																

**LEGEND:**  
**W** = Overall window outer frame width - outside  
**H** = Overall window outer frame height - outside  
 $\mathcal{C}$  = Centre line of transom/mullion  
**O/F** = Extreme edge of outer frame

**Sections:**

<b>Outerframe:</b>	ETC310	ETC312
	ETC316	ETC318
	ETC319	
<b>Sash:</b>	ETC320	ETC324
	ETC322	ETC325
	ETC323	
	<b>Transom/Mullion: ETC333</b>	



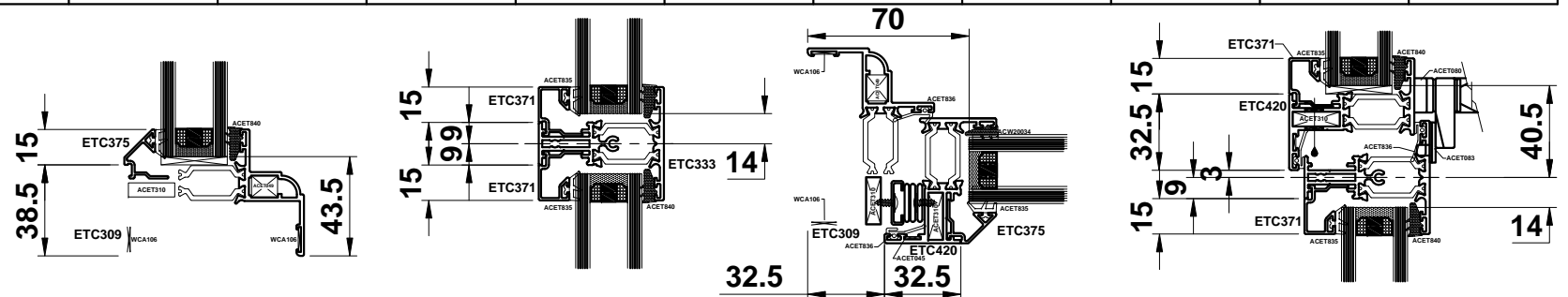
Do Not Scale From This Drawing

**Cutting Information - Standard Stays**

PART DESCRIPTIONS	TYPICAL STYLES	STYLES															
		(1)	(1)	(1)	(1)	(1)	(1)	(1)	(1)	(1)	(1)	(1)	(1)	(1)	(1)	(1)	
OUTER FRAME	HEAD & CILL	W	W	W	W	W	W	W	W	W	W	W	W	W	W	W	
	JAMBS	H	H	H	H	H	H	H	H	H	H	H	H	H	H	H	
	TRANSOM(S)		W - 77		W - 77	W - 77	W - 77		OF to $\mathcal{E}M$ - 47.5	W - 65		OF to $\mathcal{E}M$ - 47.5	$\mathcal{E}M$ to $\mathcal{E}M$ - 18	W - 77	OF to $\mathcal{E}M$ - 47.5	W - 77	
	MULLION(S)							H - 77	H - 77	OF to $\mathcal{E}T$ - 47.5	H - 77	H - 77	H - 77	OF to $\mathcal{E}T$ - 47.5	H - 77		
VENT (1)	HORIZONTAL COMPONENTS			W - 65	W - 65	W - 65	W - 65	OF to $\mathcal{E}M$ - 35.5	OF to $\mathcal{E}M$ - 35.5	OF to $\mathcal{E}M$ - 35.5	OF to $\mathcal{E}M$ - 35.5	OF to $\mathcal{E}M$ - 35.5	OF to $\mathcal{E}M$ - 35.5	OF to $\mathcal{E}M$ - 35.5	OF to $\mathcal{E}M$ - 35.5	W - 65	
	VERTICAL COMPONENTS			H - 65	OF to $\mathcal{E}T$ - 35.5	OF to $\mathcal{E}T$ - 35.5	$\mathcal{E}T$ to $\mathcal{E}T$ - 6	H - 65	H - 65	OF to $\mathcal{E}T$ - 35.5	H - 65	OF to $\mathcal{E}T$ - 35.5	H - 65	OF to $\mathcal{E}T$ - 35.5	OF to $\mathcal{E}T$ - 35.5	OF to $\mathcal{E}T$ - 35.5	
VENT (2)	HORIZONTAL COMPONENTS					W - 65		OF to $\mathcal{E}M$ - 35.5						$\mathcal{E}M$ to $\mathcal{E}M$ - 6	$\mathcal{E}M$ to $\mathcal{E}M$ - 6		
	VERTICAL COMPONENTS					OF to $\mathcal{E}T$ - 35.5		OF to $\mathcal{E}T$ - 35.5						OF to $\mathcal{E}T$ - 35.5	OF to $\mathcal{E}T$ - 35.5		
VENT (1)	GLASS WIDTH			W - 140	W - 140	W - 140	W - 140	OF to $\mathcal{E}M$ - 110.5	OF to $\mathcal{E}M$ - 110.5	OF to $\mathcal{E}M$ - 110.5	OF to $\mathcal{E}M$ - 110.5	OF to $\mathcal{E}M$ - 110.5	OF to $\mathcal{E}M$ - 110.5	OF to $\mathcal{E}M$ - 110.5	OF to $\mathcal{E}M$ - 110.5	W - 140	
	GLASS HEIGHT			H - 140	OF to $\mathcal{E}T$ - 110.5	OF to $\mathcal{E}T$ - 110.5	$\mathcal{E}T$ to $\mathcal{E}T$ - 110.5	H - 140	H - 140	OF to $\mathcal{E}T$ - 110.5	H - 140	OF to $\mathcal{E}T$ - 110.5	H - 140	OF to $\mathcal{E}T$ - 110.5	OF to $\mathcal{E}T$ - 110.5	OF to $\mathcal{E}T$ - 110.5	
VENT (2)	GLASS WIDTH							OF to $\mathcal{E}M$ - 110.5						$\mathcal{E}M$ to $\mathcal{E}M$ - 81	$\mathcal{E}M$ to $\mathcal{E}M$ - 81		
	GLASS HEIGHT							OF to $\mathcal{E}T$ - 110.5						OF to $\mathcal{E}T$ - 110.5	OF to $\mathcal{E}T$ - 110.5		
FIXED PANEL (1)	GLASS WIDTH	W - 87	W - 87		W - 87		W - 87	OF to $\mathcal{E}M$ - 57.5	OF to $\mathcal{E}M$ - 57.5	W - 87	$\mathcal{E}M$ to $\mathcal{E}M$ - 28	$\mathcal{E}M$ to $\mathcal{E}M$ - 28	$\mathcal{E}M$ to $\mathcal{E}M$ - 28	W - 87	OF to $\mathcal{E}M$ - 57.5	W - 87	
	GLASS HEIGHT	H - 87	OF to $\mathcal{E}T$ - 57.5		OF to $\mathcal{E}T$ - 57.5		OF to $\mathcal{E}T$ - 57.5	H - 87	OF to $\mathcal{E}T$ - 57.5	OF to $\mathcal{E}T$ - 57.5	H - 87	H - 87	OF to $\mathcal{E}T$ - 57.5	OF to $\mathcal{E}T$ - 57.5	H - 87	OF to $\mathcal{E}T$ - 57.5	
FIXED PANEL (2)	GLASS WIDTH																
	GLASS HEIGHT																

**LEGEND:**  
W = Overall window outer frame width - outside  
H = Overall window outer frame height - outside  
 $\mathcal{E}$  = Centre line of transom/mullion  
O/F = Extreme edge of outer frame

**Sections:**  
**Outerframe:** ETC309  
**Sash:** ETC420 ETC324  
ETC321 ETC326  
ETC323 ETC329  
**Transom/Mullion:** ETC333  
ETC334



**Do Not Scale From This Drawing**